

# HFP 147

HFP 147



**REYNAERS**  
aluminium

**Cat. nr.** 25D  
**Art. nr.** AD.089.D25B.00 (v01)  
**Edition** 06/2014



Inhoud  
Sommaire  
Content  
Inhalt

- A    Algemene informatie  
      Généralités  
      General Information  
      Allgemeine Information
- B    Algemene informatie systemen  
      Généralités séries  
      General Information System  
      Allgemeine Information System
- C    Profielen  
      Profilés  
      Profiles  
      Profile
- E    Werktekeningen  
      Coupes et débits  
      Work drawings  
      Werkzeichnungen
- F    Montagetekeningen  
      Fabrication et montage  
      Assembly drawings  
      Montagezeichnungen
- G    Toebehoren  
      Accessoires  
      Accessories  
      Zubehör







## Inhoud

INHOUDSTAFEL 25D.001-008

### Algemene informatie

SYMBOLENLIJST 25D.A.001-008

### Algemene informatie systemen

VERWERKINGSVOORSCHRIFTEN 25D.B.001-040

### Profielen

PROFIELOVERZICHT 25D.C.001-002  
 BUITENKADER 25D.C.003-004  
 BUITENKADER 3-RAIL 25D.C.005  
 4-SLAG PROFIEL 25D.C.006  
 WISSELPROFIEL 25D.C.007-008  
 BOUWAANSLUITINGEN 25D.C.009  
 HOEKPAAL 25D.C.010-012

### Werktekeningen

OMZETTINGSTABEL 25D.E.001-003  
 BESLISSINGSMATRIX 25D.E.004-005  
 OVERZICHT MANUELE CONFIGURATIES 25D.E.006  
 OVERZICHT MOTORISCHE CONFIGURATIES 25D.E.007  
 2-RAIL XQ 25D.E.008-009  
 2-RAIL XQX 25D.E.010-011  
 2-RAIL QXXQ 25D.E.012-013  
 3-RAIL XXQ 25D.E.014-017  
 OVERZICHT MANUELE CONFIGURATIES HOEKOPLOSSIN 25D.E.017\_01.001  
 OVERZICHT MOTORISCHE CONFIGURATIES HOEKOPLO: 25D.E.017\_01.002  
 BESLISSINGSMATRIX QXVXQ BUITEN 25D.E.018-019  
 2-RAIL QXVXQ BUITEN 25D.E.020-021  
 2-RAIL QXVXQ 25D.E.022-025  
 BESLISSINGSMATRIX QXVXQ BINNEN 25D.E.026-027  
 2-RAIL QXVXQ BINNEN 25D.E.028-029  
 2-RAIL QXVXQ 25D.E.030-033  
 BESLISSINGSMATRIX XQVQX BUITEN 25D.E.034-035  
 2-RAIL XQVQX BUITEN 25D.E.036-037  
 2-RAIL XQVQX 25D.E.038-041  
 BESLISSINGSMATRIX XQVQX BINNEN 25D.E.042-043  
 2-RAIL XQVQX BINNEN 25D.E.044-045  
 2-RAIL XQVQX 25D.E.046-049  
 OVERZICHT MANUELE CONFIGURATIES HOEKOPLOSSIN 25D.E.050  
 OVERZICHT MOTORISCHE CONFIGURATIES HOEKOPLO: 25D.E.051  
 3-RAIL XOQVQOX BUITEN 25D.E.052-055  
 3-RAIL XOQVQOX 25D.E.056-060

### Montagetekeningen

MONTAGE VOLGORDE 25D.F.001-003  
 MAX. TOELAATBARE AFMETINGEN 25D.F.004-011  
 UITFREZING VOOR HOEKVERBINDING METHODE 1 25D.F.012-015  
 UITFREZING VOOR HOEKVERBINDING METHODE 2 25D.F.016-017  
 UITFREZING BESLAG MANUEEL 25D.F.018-019  
 UITFREZING BESLAG MOTOR 25D.F.020-021  
 ONTWATERING TYPE XQ 25D.F.022-023  
 ONTWATERING TYPE XQX 25D.F.024-025  
 ONTWATERING TYPE QXXQ 25D.F.026-029  
 ONTWATERING XXQ 25D.F.030-033  
 VOORGESCHREVEN POSITIE VERLENGING ONDERREGEL 25D.F.033\_01.001-033\_01.002  
 AFSTANDSTUK 25D.F.034-035  
 BORSTELS 25D.F.036-037  
 ZAAGMATEN PROFIELEN 25D.F.038-043  
 MONTAGE BUITENKADER METHODE 1 25D.F.044-045  
 MONTAGE BUITENKADER METHODE 2 25D.F.046-047  
 RAIL 25D.F.048  
 STEUNBLOKKEN 25D.F.049  
 STEUNBLOK 25D.F.050-051  
 MONTAGE SCHUIVENDE VLEUGEL 25D.F.052-055  
 MONTAGE VASTE VLEUGEL 25D.F.056-057  
 DICHTINGSSTUK VOOR WISSELPROFIEL 25D.F.058-059  
 MONTAGE STELBLOKJES 25D.F.060  
 MONTAGE AFWERKINGSPROFIEL 25D.F.061  
 MONTAGE BRACKETS 25D.F.062  
 VOORBEREIDING WISSELPROFIEL 25D.F.063  
 AFREGELEN WISSELPROFIELEN 25D.F.064-066  
 AFDEKPROFIEL 25D.F.067  
 HANDGREEP SCHUIVENDE VLEUGEL 25D.F.068-069  
 AFWERKRUBBER 25D.F.070  
 STOPPER / MEENEMER 25D.F.071  
 BOUWAANSLUITINGEN 25D.F.072-073  
 BOUWAANSLUITING 25D.F.074-075  
 UITFREZING BESLAG MANUEEL 25D.F.075\_01.001-075\_01.004  
 UITFREZING BESLAG MOTOR 25D.F.075\_01.005-075\_01.006  
 2-RAIL QXVXQ BUITEN 25D.F.075\_01.007-075\_01.008  
 2-RAIL QXVXQ BINNEN 25D.F.075\_01.009-075\_01.010  
 XQVQX / XOQVQOX BUITEN 25D.F.075\_01.011-075\_01.012  
 XQVQX / XOQVQOX BINNEN 25D.F.075\_01.013-075\_01.014  
 DOORGANGSBREEDTE 25D.F.075\_01.015-075\_01.016  
 ONTWATERING TYPE QXVXQ BUITEN 25D.F.076-077  
 ZAAGMATEN PROFIELEN BUITEN 25D.F.077\_01.001-077\_01.002  
 ONTWATERING TYPE QXVXQ BINNEN 25D.F.078-079  
 ZAAGMATEN PROFIELEN BINNEN 25D.F.079\_01.001-079\_01.002  
 ONTWATERING TYPE XQVQX BUITEN 25D.F.080  
 ONTWATERING TYPE QXVXQ BUITEN 25D.F.081  
 XQVQX BUITEN 25D.F.081\_01.001-081\_01.002  
 ZAAGMATEN PROFIELEN BUITEN 25D.F.081\_01.003-081\_01.004  
 ONTWATERING TYPE XQVQX INSIDE 25D.F.082-083  
 XQVQX BINNEN 25D.F.083\_01.001-083\_01.002  
 ZAAGMATEN PROFIELEN BINNEN 25D.F.083\_01.003-083\_01.004

ZAAGMATEN PROFIELEN 25D.F.084-085  
 KOPPELSTUK 25D.F.086-089  
 MONTAGE HOEK HORIZONTALE 25D.F.090-091  
 MONTAGE HOEK VERTICALE 25D.F.092-093  
 STOPPER / MEENEMER 25D.F.094-097  
 FIXED GLASS 25D.F.098-099  
 BOUWAANSLUITING - HOEK BUITEN 25D.F.100-101  
 BOUWAANSLUITING - HOEK BINNEN 25D.F.102-103  
 BOUWAANSLUITING - CORNER CONCAVE 25D.F.104

### Toebehoren

OVERZICHT 25D.G.001-002  
 HANDGREEP 25D.G.003  
 SLOTEN SCHUIFDEUR 25D.G.004  
 MOTOR 25D.G.005-006  
 DICHTINGEN 25D.G.007-010  
 FOAM 25D.G.011  
 SCHROEF 25D.G.012  
 BESLAG 25D.G.013  
 AFDEKKAP 25D.G.014  
 DIVERSEN 25D.G.015-017  
 HOEKEN 25D.G.018  
 ANKER 25D.G.019  
 LOOPWAGEN 25D.G.020





## Sommaire

TABLE DES MATIERES 25D.001-008

### Généralités

LISTE DES SYMBOLES 25D.A.001-008

### Généralités séries

PRESCRIPTIONS DE MISE EN OEUVRE 25D.B.001-040

### Profilés

APERCU DES PROFILES 25D.C.001-002  
DORMANT 25D.C.003-004  
DORMANT 3-RAIL 25D.C.005  
PROFILE 4 VANTAUX 25D.C.006  
CHICANE 25D.C.007-008  
RACCORDEMENTS AU BATIMENT 25D.C.009  
PROFILE D'ANGLE 25D.C.010-012

### Coupes et débits

TABLE DE CONVERSION 25D.E.001-003  
MATRICE DE DECISION 25D.E.004-005  
APERCU CONFIGURATIONS MANUELE 25D.E.006  
APERCU CONFIGURATIONS MOTEUR 25D.E.007  
2-RAIL XQ 25D.E.008-009  
2-RAIL XQX 25D.E.010-011  
2-RAIL QXXQ 25D.E.012-013  
3-RAIL XXQ 25D.E.014-017  
APERCU CONFIGURATIONS MANUELE SOLUTION ANGUL 25D.E.017\_01.001  
APERCU CONFIGURATIONS MOTEUR SOLUTION ANGUL 25D.E.017\_01.002  
MATRICE DE DECISION QXVXQ EXTERIEURE 25D.E.018-019  
2-RAIL QXVXQ EXTERIEURE 25D.E.020-021  
2-RAIL QXVXQ 25D.E.022-025  
MATRICE DE DECISION QXVXQ INTERIEUR 25D.E.026-027  
2-RAIL QXVXQ INTERIEUR 25D.E.028-029  
2-RAIL QXVXQ 25D.E.030-033  
MATRICE DE DECISION XQVQX EXTERIEURE 25D.E.034-035  
2-RAIL XQVQX EXTERIEURE 25D.E.036-037  
2-RAIL XQVQX 25D.E.038-041  
MATRICE DE DECISION XQVQX INTERIEUR 25D.E.042-043  
2-RAIL XQVQX INTERIEUR 25D.E.044-045  
2-RAIL XQVQX 25D.E.046-049  
APERCU CONFIGURATIONS MANUELE SOLUTION ANGUL 25D.E.050  
APERCU CONFIGURATIONS MOTEUR SOLUTION ANGUL 25D.E.051  
3-RAIL XOQVQOX EXTERIEURE 25D.E.052-055  
3-RAIL XOQVQOX 25D.E.056-060

### Fabrication et montage

ORDRE DE MONTAGE 25D.F.001-003  
DIMENSIONS MAX. ADMISSIBLE 25D.F.004-011  
FRAISAGE POUR EQUERRE METHODE 1 25D.F.012-015  
FRAISAGE POUR EQUERRE METHODE 2 25D.F.016-017  
FRAISAGE ACCESSOIRES MANUEL 25D.F.018-019  
FRAISAGE ACCESSOIRES MOTEUR 25D.F.020-021  
DRAINAGE TYPE XQ 25D.F.022-023  
DRAINAGE TYPE XQX 25D.F.024-025  
DRAINAGE TYPE QXXQ 25D.F.026-029  
DRAINAGE XXQ 25D.F.030-033  
POSITION PRESCRIT DE L'EXTENSION DU PROFIL DESSINÉ 25D.F.033\_01.001-033\_01.002  
PIECE D'ECARTEMENT 25D.F.034-035  
BROSSES 25D.F.036-037  
MESURES DE SCIAGE PROFILES 25D.F.038-043  
ASSEMBLAGE DORMANT METHODE 1 25D.F.044-045  
ASSEMBLAGE DORMANT METHODE 2 25D.F.046-047  
RAIL 25D.F.048  
SUPPORTS 25D.F.049  
SUPPORT 25D.F.050-051  
MONTAGE VANTAIL COULISSANT 25D.F.052-055  
MONTAGE OUVRANT FIXE 25D.F.056-057  
JOINT D'ASSEMBLAGE POUR CHICANE 25D.F.058-059  
MONTAGE CALES D'AJUSTEMENT 25D.F.060  
MONTAGE PROFILE DE FINITION 25D.F.061  
MONTAGE 25D.F.062  
PREPARATION CHICANE 25D.F.063  
AJUSTÉE CHICANES 25D.F.064-066  
PROFILE DE RECOUVREMENT 25D.F.067  
MAIN COURANTE VANTAIL COULISSANT 25D.F.068-069  
JOINT DE FINITION 25D.F.070  
ARRETEUR / ENTRAINEUR 25D.F.071  
RACCORDEMENTS AU BATIMENT 25D.F.072-073  
RACCORDEMENT AU BATIMENT 25D.F.074-075  
FRAISAGE ACCESSOIRES MANUEL 25D.F.075\_01.001-075\_01.004  
FRAISAGE ACCESSOIRES MOTEUR 25D.F.075\_01.005-075\_01.006  
2-RAIL QXVXQ EXTERIEURE 25D.F.075\_01.007-075\_01.008  
2-RAIL QXVXQ INTERIEUR 25D.F.075\_01.009-075\_01.010  
XQVQX / XOQVQOX EXTERIEURE 25D.F.075\_01.011-075\_01.012  
XQVQX / XOQVQOX INTERIEURE 25D.F.075\_01.013-075\_01.014  
LARGEUR DE PASSAGE 25D.F.075\_01.015-075\_01.016  
DRAINAGE TYPE QXVXQ EXTERIEURE 25D.F.076-077  
MESURES DE SCIAGE PROFILES EXTERIEUR 25D.F.077\_01.001-077\_01.002  
DRAINAGE TYPE QXVXQ INTERIEUR 25D.F.078-079  
MESURES DE SCIAGE PROFILES INTERIEUR 25D.F.079\_01.001-079\_01.002  
DRAINAGE TYPE XQVQX EXTERIEURE 25D.F.080  
DRAINAGE TYPE QXVXQ EXTERIEURE 25D.F.081  
XQVQX EXTERIEURE 25D.F.081\_01.001-081\_01.002  
MESURES DE SCIAGE PROFILES EXTERIEUR 25D.F.081\_01.003-081\_01.004  
DRAINAGE TYPE XQVQX INTERIEUR 25D.F.082-083  
XQVQX INTERIEURE 25D.F.083\_01.001-083\_01.002  
MESURES DE SCIAGE PROFILES INTERIEUR 25D.F.083\_01.003-083\_01.004

MESURES DE SCIAGE PROFILES 25D.F.084-085  
PIECE DE RACCORDEMENT 25D.F.086-089  
MONTAGE COIN HORIZONTAL 25D.F.090-091  
MONTAGE COIN VERTICAL 25D.F.092-093  
ARRETEUR / ENTRAINEUR 25D.F.094-097  
VERRRE FIXE 25D.F.098-099  
RACCORDEMENT AU BATIMENT - COIN EXTERIEUR 25D.F.100-101  
RACCORDEMENT AU BATIMENT - COIN INTERIEUR 25D.F.102-103  
RACCORDEMENT AU BATIMENT - CORNER CONCAVES 25D.F.104

### Accessoires

APERCU 25D.G.001-002  
MAIN COURANTE 25D.G.003  
SERRURES PORTE COULISSANTE 25D.G.004  
MOTEUR 25D.G.005-006  
JOINTS 25D.G.007-010  
FOAM 25D.G.011  
VIS 25D.G.012  
ACCESSORIES 25D.G.013  
CAPUCHON 25D.G.014  
DIVERS 25D.G.015-017  
EQUERRES 25D.G.018  
ANCRAGE 25D.G.019  
ROULETTES 25D.G.020





## Content

TABLE OF CONTENTS 25D.001-008

## General Information

LIST OF SYMBOLS 25D.A.001-008

## General Information System

PROCESSING DATA 25D.B.001-040

## Profiles

PROFILE OVERVIEW 25D.C.001-002  
OUTER FRAME 25D.C.003-004  
OUTER FRAME 3-RAIL 25D.C.005  
4 DOORS PROFILE 25D.C.006  
MEETING SECTION 25D.C.007-008  
BUILDING CONNECTIONS 25D.C.009  
CORNER PROFILE 25D.C.010-012

## Work drawings

CONVERSION TABLE 25D.E.001-003  
DECISION MATRIX 25D.E.004-005  
OVERVIEW MANUAL CONFIGURATIONS 25D.E.006  
OVERVIEW MOTOR CONFIGURATIONS 25D.E.007  
2-RAIL XQ 25D.E.008-009  
2-RAIL XQX 25D.E.010-011  
2-RAIL QXXQ 25D.E.012-013  
3-RAIL XXQ 25D.E.014-017  
OVERVIEW MANUAL CONFIGURATIONS CORNER SOLUT 25D.E.017\_01.001  
OVERVIEW MOTOR CONFIGURATIONS CORNER SOLUTI 25D.E.017\_01.002  
DECISION MATRIX QXVXQ OUTSIDE 25D.E.018-019  
2-RAIL QXVXQ OUTSIDE 25D.E.020-021  
2-RAIL QXVXQ 25D.E.022-025  
DECISION MATRIX QXVXQ INNER 25D.E.026-027  
2-RAIL QXVXQ INNER 25D.E.028-029  
2-RAIL QXVXQ 25D.E.030-033  
DECISION MATRIX XQVQX OUTSIDE 25D.E.034-035  
2-RAIL XQVQX OUTSIDE 25D.E.036-037  
2-RAIL XQVQX 25D.E.038-041  
DECISION MATRIX XQVQX INNER 25D.E.042-043  
2-RAIL XQVQX INNER 25D.E.044-045  
2-RAIL XQVQX 25D.E.046-049  
OVERVIEW MANUAL CONFIGURATIONS CORNER SOLUT 25D.E.050  
OVERVIEW MOTOR CONFIGURATIONS CORNER SOLUTI 25D.E.051  
3-RAIL XQVQOX OUTSIDE 25D.E.052-055  
3-RAIL XQVQOX 25D.E.056-060

## Assembly drawings

ORDER OF ASSEMBLY 25D.F.001-003  
MAX. ADMISSIBLE SIZES 25D.F.004-011  
MILLING FOR CORNER CLEAT METHOD 1 25D.F.012-015  
MILLING FOR CORNER CLEAT METHOD 2 25D.F.016-017  
MILLING ACCESSORIES MANUAL 25D.F.018-019  
MILLING ACCESSORIES MOTOR 25D.F.020-021  
DRAINAGE TYPE XQ 25D.F.022-023  
DRAINAGE TYPE XQX 25D.F.024-025  
DRAINAGE TYPE QXXQ 25D.F.026-029  
DRAINAGE XXQ 25D.F.030-033  
PRESCRIBED POSITION OF THE BOTTOM EXTENSION 25D.F.033\_01.001-033\_01.002  
DISTANCE PIECE 25D.F.034-035  
BRUSHES 25D.F.036-037  
CUTTING SIZES PROFILES 25D.F.038-043  
ASSEMBLY OUTER FRAME METHOD 1 25D.F.044-045  
ASSEMBLY OUTER FRAME METHOD 2 25D.F.046-047  
RAIL 25D.F.048  
SUPPORT PIECES 25D.F.049  
SUPPORT PIECE 25D.F.050-051  
ASSEMBLY SLIDING VENT 25D.F.052-055  
ASSEMBLY FIXED FRAME 25D.F.056-057  
GASKET FOR MEETING SECTION PERFIL CENTRAL 25D.F.058-059  
ASSEMBLY ADJUSTING BLOCKS 25D.F.060  
ASSEMBLY FINISHING PROFILE 25D.F.061  
ASSEMBLY 25D.F.062  
PREPARATION MEETING SECTION 25D.F.063  
ADJUST MEETING SECTION 25D.F.064-066  
COVERING PROFILE 25D.F.067  
HANDRAIL SLIDING VENT 25D.F.068-069  
FACE GASKET 25D.F.070  
STOPPER / DRIVE PLATE 25D.F.071  
BUILDING CONNECTIONS 25D.F.072-073  
BUILDING CONNECTION 25D.F.074-075  
MILLING ACCESSORIES MANUAL 25D.F.075\_01.001-075\_01.004  
MILLING ACCESSORIES MOTOR 25D.F.075\_01.005-075\_01.006  
2-RAIL QXVXQ OUTSIDE 25D.F.075\_01.007-075\_01.008  
2-RAIL QXVXQ INNER 25D.F.075\_01.009-075\_01.010  
XQVQX / XQVQOX OUTSIDE 25D.F.075\_01.011-075\_01.012  
XQVQX / XQVQOX INSIDE 25D.F.075\_01.013-075\_01.014  
PASSAGE WIDTH 25D.F.075\_01.015-075\_01.016  
DRAINAGE TYPE QXVXQ OUTSIDE 25D.F.076-077  
CUTTING SIZES PROFILES OUTSIDE 25D.F.077\_01.001-077\_01.002  
DRAINAGE TYPE QXVXQ INSIDE 25D.F.078-079  
CUTTING SIZES PROFILES INSIDE 25D.F.079\_01.001-079\_01.002  
DRAINAGE TYPE XQVQX OUTSIDE 25D.F.080  
DRAINAGE TYPE QXVXQ OUTSIDE 25D.F.081  
XQVQX OUTSIDE 25D.F.081\_01.001-081\_01.002  
CUTTING SIZES PROFILES OUTSIDE 25D.F.081\_01.003-081\_01.004  
DRAINAGE TYPE XQVQX INSIDE 25D.F.082-083  
XQVQX INSIDE 25D.F.083\_01.001-083\_01.002  
CUTTING SIZES PROFILES INSIDE 25D.F.083\_01.003-083\_01.004

CUTTING SIZES PROFILES 25D.F.084-085  
CONNECTION PIECE 25D.F.086-089  
ASSEMBLY CORNER HORIZONTAL 25D.F.090-091  
ASSEMBLY CORNER VERTICAL 25D.F.092-093  
STOPPER / DRIVE PLATE 25D.F.094-097  
FIXED GLASS 25D.F.098-099  
BUILDING CONNECTION - OUTSIDE CORNER 25D.F.100-101  
BUILDING CONNECTION - INSIDE CORNER 25D.F.102-103  
BUILDING CONNECTION - CORNER CONCAVE 25D.F.104

## Accessories

OVERVIEW 25D.G.001-002  
HANDRAIL 25D.G.003  
LOCKS SLIDING DOOR 25D.G.004  
MOTOR 25D.G.005-006  
GASKETS 25D.G.007-010  
FOAM 25D.G.011  
SCREW 25D.G.012  
ACCESSORIES 25D.G.013  
FACE CAP 25D.G.014  
MISCELLANEOUS 25D.G.015-017  
CORNER CLEATS 25D.G.018  
ANCHOR 25D.G.019  
ROLLERS 25D.G.020





## Inhalt

INHALTSANGABE 25D.001-008

### Allgemeine Information

ZEICHENERKLAERUNG 25D.A.001-008

### Allgemeine Information System

VERARBEITUNGSVORSCHRIFTEN 25D.B.001-040

### Profile

PROFILUEBERSICHT 25D.C.001-002  
BLENDRAHMEN 25D.C.003-004  
BLENDRAHMEN 3-RAIL 25D.C.005  
4-SCHLAG PROFIL 25D.C.006  
WECHSELPROFIL 25D.C.007-008  
BAUANSCHLUESSE 25D.C.009  
ECKPROFIL 25D.C.010-012

### Werkzeichnungen

UMRECHNUNGSTABELLE 25D.E.001-003  
ENTSCHEIDUNGSMATRIX 25D.E.004-005  
UEBERSICHT MANUELE KONFIGURATIONEN 25D.E.006  
UEBERSICHT MOTOR KONFIGURATIONEN 25D.E.007  
2-RAIL XQ 25D.E.008-009  
2-RAIL XQX 25D.E.010-011  
2-RAIL QXXQ 25D.E.012-013  
3-RAIL XXQ 25D.E.014-017  
UEBERSICHT MANUELE KONFIGURATIONEN ECKLOSUN 25D.E.017\_01.001  
UEBERSICHT MOTOR KONFIGURATIONEN ECKLOSUNG 25D.E.017\_01.002  
ENTSCHEIDUNGSMATRIX QXVXQ AUSSEN 25D.E.018-019  
2-RAIL QXVXQ AUSSEN 25D.E.020-021  
2-RAIL QXVXQ 25D.E.022-025  
ENTSCHEIDUNGSMATRIX QXVXQ INNEN 25D.E.026-027  
2-RAIL QXVXQ INNEN 25D.E.028-029  
2-RAIL QXVXQ 25D.E.030-033  
ENTSCHEIDUNGSMATRIX XQVQX AUSSEN 25D.E.034-035  
2-RAIL XQVQX AUSSEN 25D.E.036-037  
2-RAIL XQVQX 25D.E.038-041  
ENTSCHEIDUNGSMATRIX XQVQX INNEN 25D.E.042-043  
2-RAIL XQVQX INNEN 25D.E.044-045  
2-RAIL XQVQX 25D.E.046-049  
UEBERSICHT MANUELE KONFIGURATIONEN ECKLOSUN 25D.E.050  
UEBERSICHT MOTOR KONFIGURATIONEN ECKLOSUNG 25D.E.051  
3-RAIL XOQVQOX AUSSEN 25D.E.052-055  
3-RAIL XOQVQOX 25D.E.056-060

### Montagezeichnungen

RIEHENFOLGE VON MONTAGE 25D.F.001-003  
MAX. ZULAESSIGE ABMESSUNGEN 25D.F.004-011  
AUSFRAESUNG FUER ECKVERBINDER METHODE 1 25D.F.012-015  
AUSFRAESUNG FUER ECKVERBINDER METHODE 2 25D.F.016-017  
AUSFRAESUNG BESCHLAG MANUELLE 25D.F.018-019  
AUSFRAESUNG BESCHLAG ANTRIEB 25D.F.020-021  
ENTWAESSERUNG TYP XQ 25D.F.022-023  
ENTWAESSERUNG TYPE XQX 25D.F.024-025  
ENTWAESSERUNG TYPE QXXQ 25D.F.026-029  
ENTWAESSERUNG XXQ 25D.F.030-033  
FESTGESETZTE POSITION VERLAENGUNG UNDERRIEGE 25D.F.033\_01.001-033\_01.002  
DISTANZSTUECK 25D.F.034-035  
BUERSTEN 25D.F.036-037  
SAEGEZUSCHNITTE PROFILE 25D.F.038-043  
MONTAGE BLENDRAHMEN METHODE 1 25D.F.044-045  
MONTAGE BLENDRAHMEN METHODE 2 25D.F.046-047  
RAIL 25D.F.048  
STUETZKLOTZE 25D.F.049  
STUETZKLOTZ 25D.F.050-051  
MONTAGE SCHIEBEFLUEGEL 25D.F.052-055  
MONTAGE FESTEN FLUEGEL 25D.F.056-057  
DICHTUNGSSTUECK FUER WECHSELPROFIL 25D.F.058-059  
MONTAGE DISTANZKLOTZ 25D.F.060  
MONTAGE AUSFUEHRUNGSPROFIL 25D.F.061  
MONTAGE 25D.F.062  
VORBREITUNG WECHSELPROFILE 25D.F.063  
EINSTELLEN WECHSELPROFILE 25D.F.064-066  
ABDECKPROFIL 25D.F.067  
HANDLAUF SCHIEBEFLUEGEL 25D.F.068-069  
ABDECKDICHTUNG 25D.F.070  
STOPFEN / MITNEHMER 25D.F.071  
BAUANSCHLUESSE 25D.F.072-073  
BAUANSCHLUSS 25D.F.074-075  
AUSFRAESUNG BESCHLAG MANUELLE 25D.F.075\_01.001-075\_01.004  
AUSFRAESUNG BESCHLAG ANTRIEB 25D.F.075\_01.005-075\_01.006  
2-RAIL QXVXQ AUSSEN 25D.F.075\_01.007-075\_01.008  
2-RAIL QXVXQ INNEN 25D.F.075\_01.009-075\_01.010  
XQVQX / XOQVQOX AUSSEN 25D.F.075\_01.011-075\_01.012  
XQVQX / XOQVQOX INNEN 25D.F.075\_01.013-075\_01.014  
DURCHGANGSBREITE 25D.F.075\_01.015-075\_01.016  
ENTWAESSERUNG TYP QXVXQ AUSSEN 25D.F.076-077  
SAEGEZUSCHNITTE PROFILE AUSSEN 25D.F.077\_01.001-077\_01.002  
ENTWAESSERUNG TYP QXVXQ INNEN 25D.F.078-079  
SAEGEZUSCHNITTE PROFILE INNEN 25D.F.079\_01.001-079\_01.002  
ENTWAESSERUNG TYP XQVQX AUSSEN 25D.F.080  
ENTWAESSERUNG TYP QXVXQ AUSSEN 25D.F.081  
XQVQX AUSSEN 25D.F.081\_01.001-081\_01.002  
SAEGEZUSCHNITTE PROFILE AUSSEN 25D.F.081\_01.003-081\_01.004  
ENTWAESSERUNG TYP XQVQX INNEN 25D.F.082-083  
XQVQX INNEN 25D.F.083\_01.001-083\_01.002  
SAEGEZUSCHNITTE PROFILE INNEN 25D.F.083\_01.003-083\_01.004







SAEGEZUSCHNITTE PROFILE 25D.F.084-085  
KUPPLUNGSSTUECK 25D.F.086-089  
MONTAGE CORNER HORIZONTAL 25D.F.090-091  
MONTAGE CORNER VERTICAL 25D.F.092-093  
STOPFEN / MITNEHMER 25D.F.094-097  
FIXED GLASS 25D.F.098-099  
BAUANSCHLUSS - AUSSERE ECKE 25D.F.100-101  
BAUANSCHLUSS - INNERE ECKE 25D.F.102-103  
BAUANSCHLUSS - CORNER CONCAVE 25D.F.104







### Zubehör

UEBERSICHT 25D.G.001-002  
HANDLAUF 25D.G.003  
SCHLOESSER SCHIEBETUER 25D.G.004  
ANTRIEB 25D.G.005-006  
DICHTUNGEN 25D.G.007-010  
FOAM 25D.G.011  
SCHRAUBE 25D.G.012  
BESCHLAG 25D.G.013  
ABDECKKAPPE 25D.G.014  
DIVERSE 25D.G.015-017  
ECKWINKEL 25D.G.018  
ANKER 25D.G.019  
LAUFWAGEN 25D.G.020





					
25D.A.001	05/2014	D0071480	25D.F.028	05/2014	D0095243
25D.A.002	05/2014	D0071481	25D.F.030	05/2014	D0096401
25D.A.003	05/2014	D0071482	25D.F.032	05/2014	D0096403
25D.A.004	05/2014	D0071483	25D.F.033_01.001	06/2014	D0096936
25D.A.005	05/2014	D0071484	25D.F.034	05/2014	D0095569
25D.A.006	05/2014	D0071485	25D.F.036	06/2014	D0096410
25D.A.007	05/2014	D0071486	25D.F.038	06/2014	D0093154
25D.A.008	05/2014		25D.F.040	06/2014	D0093170
25D.B.001	06/2014	PD.089.D25B.00-DU	25D.F.042	05/2014	D0095291
25D.B.011	06/2014	PD.089.D25B.00-FR	25D.F.044	05/2014	D0093213
25D.B.021	06/2014	PD.089.D25B.00-EN	25D.F.046	05/2014	D0093184
25D.B.031	06/2014	PD.089.D25B.00-GE	25D.F.048	05/2014	D0093182
25D.C.001	05/2014	D0095359	25D.F.050	05/2014	D0093188
25D.C.002	05/2014	D0095360	25D.F.052	05/2014	D0093190
25D.C.003	05/2014	D0092895	25D.F.054	05/2014	D0093194
25D.C.004	05/2014	D0092897	25D.F.056	05/2014	D0093193
25D.C.005	05/2014	D0095183	25D.F.058	05/2014	D0093250
25D.C.006	05/2014	D0092898	25D.F.060	05/2014	D0093251
25D.C.007	05/2014	D0092899	25D.F.062	05/2014	D0093241
25D.C.008	05/2014	D0095019	25D.F.064	05/2014	D0093300
25D.C.009	05/2014	D0095021	25D.F.066	05/2014	D0093266
25D.C.010	06/2014	D2000446	25D.F.068	05/2014	D0093210
25D.C.011	05/2014	D2000447	25D.F.070	05/2014	D0093246
25D.C.012	05/2014		25D.F.072	05/2014	D0093395
25D.E.001	05/2014		25D.F.074	05/2014	D0095264
25D.E.002	06/2014	D0095238	25D.F.075_01.001	06/2014	D0096926
25D.E.004	05/2014	D0095280	25D.F.075_01.003	06/2014	D0096927
25D.E.006	06/2014	D0095246	25D.F.075_01.005	06/2014	D2000528
25D.E.008	05/2014	D0092903	25D.F.075_01.007	06/2014	D2000530
25D.E.010	05/2014	D0093389	25D.F.075_01.009	06/2014	D2000529
25D.E.012	05/2014	D0093393	25D.F.075_01.011	06/2014	D2000532
25D.E.014	05/2014	D0095186	25D.F.075_01.013	06/2014	D2000531
25D.E.016	05/2014	D0095226	25D.F.075_01.015	06/2014	D2000533
25D.E.017_01.001	06/2014	D2000451	25D.F.076	05/2014	D2000457
25D.E.018	06/2014	D2000452	25D.F.077_01.001	06/2014	D2000550
25D.E.020	05/2014	D2000454	25D.F.078	05/2014	D2000458
25D.E.022	06/2014	D2000518	25D.F.079_01.001	06/2014	D2000549
25D.E.024	05/2014	D2000519	25D.F.080	05/2014	D2000486
25D.E.026	06/2014	D2000453	25D.F.081_01.001	06/2014	D0096941
25D.E.028	05/2014	D2000455	25D.F.081_01.003	06/2014	D2000558
25D.E.030	06/2014	D2000456	25D.F.082	05/2014	D2000487
25D.E.032	05/2014	D2000491	25D.F.083_01.001	06/2014	D0096940
25D.E.034	06/2014	D2000509	25D.F.083_01.003	06/2014	D2000557
25D.E.036	05/2014	D2000482	25D.F.084	05/2014	D2000459
25D.E.038	06/2014	D2000520	25D.F.086	05/2014	D2000460
25D.E.040	05/2014	D2000521	25D.F.088	05/2014	D2000464
25D.E.042	06/2014	D2000480	25D.F.090	05/2014	D2000461
25D.E.044	05/2014	D2000481	25D.F.092	06/2014	D0096425
25D.E.046	06/2014	D2000511	25D.F.094	05/2014	D2000496
25D.E.048	05/2014	D2000512	25D.F.096	05/2014	D2000498
25D.E.050	05/2014	D2000493	25D.F.098	05/2014	D0096424
25D.E.052	06/2014	D2000505	25D.F.100	05/2014	D2000462
25D.E.054	05/2014	D2000506	25D.F.102	05/2014	D2000463
25D.E.056	06/2014	D2000507	25D.F.104	05/2014	
25D.E.058	05/2014	D2000508	25D.G.001	05/2014	D0096536
25D.E.060	05/2014		25D.G.002	05/2014	D0096537
25D.F.001	05/2014		25D.G.003	05/2014	D0095248
25D.F.002	06/2014	D0096187	25D.G.004	05/2014	D0095249
25D.F.004	05/2014	D0095355	25D.G.005	05/2014	D0095250
25D.F.006	05/2014	D0095284	25D.G.006	05/2014	D0095251
25D.F.008	05/2014	D0095287	25D.G.007	05/2014	D0095252
25D.F.010	05/2014	D0095288	25D.G.008	05/2014	D0095253
25D.F.012	05/2014	D0093137	25D.G.009	05/2014	D0095254
25D.F.014	05/2014	D0093339	25D.G.010	05/2014	D0095255
25D.F.016	05/2014	D0093138	25D.G.011	05/2014	D2000449
25D.F.018	05/2014	D0093141	25D.G.012	05/2014	D0095256
25D.F.020	05/2014	D0095224	25D.G.013	05/2014	D2000465
25D.F.022	05/2014	D0095240	25D.G.014	05/2014	D0095258
25D.F.024	05/2014	D0095241	25D.G.015	05/2014	D0095257
25D.F.026	05/2014	D0095242	25D.G.016	05/2014	D0095371

					
25D.G.017	05/2014	D0095259			
25D.G.018	05/2014	D2000450			
25D.G.019	05/2014	D0095260			
25D.G.020	05/2014	D0096027			
25D.G.021	05/2014	D0095261			
25D.G.022	05/2014				
25D.001	06/2014				
25D.003	06/2014				
25D.005	06/2014				
25D.007	06/2014				

---

# A

---

































Algemene informatie

Généralités



































General Information





































Allgemeine Information

































	Profil Profilé Profile Profil	Perfil Profil Profil		Verstek Onglet Mitre Gehrung	Inglete Polaczenie katowe Taglio
	Anodisatie- of lakoppervlakte Surface anodisée ou laquée Anodizing or coating surface Eloxierde oder lackierte Oberfläche	Superficie anodizada o lacada Powierzchnia anodowana lub malowana Superficie anodizzata o verniciata	#	Aantal Nombre Number Anzahl	Número Ilość Numero
	Polijsoppervlakte Surface à polir Polishing surface Polieroberfläche	Superficie pulida Powierzchnia polerowana Superficie lucidata		Zie pagina Voir page See page Siehe Seite	Ver página Patrz stronę Vedi pagina
	Lengte Longueur Length Länge	Longitud Długość Lunghezza		Type toebehoren Type accessoires Type accessories Typ Zubehör	Tipos de accesorios Rodzaj okuc Tipo di accessorio
	Afmetingen Dimensions Dimensions Abmessungen	Dimensiones Wymiary Dimensioni		Glasmaten Dimensions vitres Glass sizes Glasmasse	Dimensiones de los vidrios Wymiary szyby Dimensioni del vetro
	Toepassing Application Application Anwendung	Aplicación Zastosowanie Utilizzo		Toepassing Application Utilization Anwendung	Aplicación Zastosowanie Riferimenti
	Bevestigingsmiddelen Moyens de fixation Fixations Befestigungsmittel	Fijación Mocowanie Fissaggio		Asymmetrisch profiel Profilé asymétrique Asymmetrical profile Asymmetrisches Profil	Perfil asimétrico Profil niesymetryczny Profilo asimmetrico
	Schroeven niet meegeleverd Fourniture sans vis Delivered without screws Lieferung ohne Schrauben	Entregado sin tornillos Dostarczane bez wkrętów Consegnato senza viti		Pagina Page Page Seite	Página Strona Pagina
	Montagevolgorde Ordre de montage The order of assembly Montagereihenfolge	Orden de montaje Kolejność montażu Ordine di montaggio		Laatste editie Dernière édition Last edition Letzte Edition	Edición Poprzednie wydanie Ultima edizione
	Dichtingsmiddel Matière d'étanchéité Sealing agent Abdichtungsmittel	Agente sellante Masa uszczelniająca Siliconatura		Vorige blz Page précédente Previous page Vorige Seite	Página siguiente Poprzednia strona Pagina precedente
	Verlijmen Coller Glue Verkleben	Collado Klej Colla		Verstevigingsprofiel Profil de renforcement Reinforcement profile Verstärkungsprofil	Perfil refuerzo Profil wzmocniający Profilo di rinforzo
	Vulcaniseerlijm Colle vulcanisante Vulcanizing glue Vulkanisierkleber	Vulcanizante Klej wulkanizacyjny Colla vulcanizzante		Links van buiten gezien Gauche vue extérieur Left seen from outside Links Aussehen	Vista izquierda desde el exterior Na lewo widok od zewnątrz Sinistro visto da fuori
	Referentiemaat Dimension de référence Reference dimension Referenzmass	Dimension de referencia Punkt odniesienia wymiarowania Dimensioni di riferimento		Rechts van buiten gezien Droite vue extérieur Right seen from outside Rechts Aussehen	Vista derecha desde el exterior Na prawa widok od zewnątrz Destro visto da fuori
	Merkteken Marquage Mark Merkmale	Indicación Znak Contrassegno		Reynaprotector Reynaprotector Reynaprotector Reynaprotector	Reynaprotector Reynaprotector Reynaprotector Reynaprotector
	Struktureel gelijmd glaswerk Vitrage extérieur collé Structural sealing glazing UV-beständiger Scheibenrandverbund	Sellado acristalado estructural Szyba klejona spoiwem konstrukcyjnym Siliconatura vetro strutturale		Primaire zichtzijde van een profiel Côté visible primaire d'un profilé Primary visible side of a profile Primäre sichtbare Seite eines Profils	Cara vista principal del perfil Główna widoczna powierzchnia profilu Primo lato visibile di un profilo
	Secundaire zichtzijde van een profiel Côté visible secondaire d'un profilé Secondary visible side of a profile Sekund. sichtbare Seite eines Profils	Cara vista secundaria del perfil Drugorzędna widoczna powierzchnia profilu Secondo lato visibile di un profilo		Kleur buitenschaal (e) eerst aangeven in geval van bicolor (.69) En cas de bicolor (.69) il faut indiquer d'abord la couleur du profilé extérieur (e) For bicolor profiles (.69) first of all one should indicate the colour of the outer profile (e) Falls zweifarbig (.69) soll man erst die Farbe des Aussenprofils (e) angeben	Para perfil en bicolor (.69) debe indicarse primero el color del perfil externo (e) Dla profili dwukolorowych (.69) w pierwszej kolejności powinny być wskazany kolor zewnętrznej strony profilu (e) Nei profili bicolore (.69) prima di tutto indicare il colore del profilo esterno (e)

































	Inbraakwerend Anti-vol Burglar proof Einbruchhemmend	Protección anti- robo Antywłamaniowe Antiscasso		Pershoekverbinding Equerre à sertir Crimp corner cleat Presseckverbinder	Escuadra de ensamblar Naroznik zaciskany Squadrette a cianfrinare
	Basisveiligheid Sécurité de base Basic safety Basissicherheit	Seguridad básica Antywłamaniowosc podstawowa Antiscasso base		Hoekverbinding met schroefhoek (* enkel voor klembaar beslag Equerre à blocage (* seulement pour accessoires encastrables Corner cleat with screw (* only for clamping accessories Eckverbinder mit Spannschraube (* nur für klemmbaren Beschlag	Escuadra de atornillar (* solo para accesorios apretables Naroznik skrecany (* tylko dla akcesoriow zatrzaskiwanych Squadrette ad avvitare (* solo per accessori a scatto
	Testen uitgevoerd volgens norm DIN V ENV 1627 Essais effectués par conformément la norme DIN V ENV 1627 Tests carried out according to standard DIN V ENV 1627 Einbruchhemmende Prüfungen gemäß Norm DIN V ENV 1627	Ensayos realizados según norma DIN V ENV 1627 Badania wykonane według normy DIN V ENV 1627 Antiscasso secondo DIN V ENV 1627		T-verbinding met schroef Jonction-T avec vis T-bracket with screw T-Verbinder mit Schraube	Tope de union con tornillo Lacznik teowy skrecany Giunti con viti
	Testen uitgevoerd volgens norm NEN 5096 + ENV 1627 Essais effectués par conformément la norme NEN 5096 + ENV 1627 Tests carried out according to standard NEN 5096 + ENV 1627 Einbruchhemmende Prüfungen gemäß Norm NEN5096 + ENV1627	Ensayos realizados según norma NEN 5096 + ENV 1627 Badania wykonane norm NEN 5098 + ENV 1627 Antiscasso secondo NEN 5098 + ENV 1627		T-verbinding met schroef voor buitendraaiend raam Jonction-T avec vis pour fenêtre ouvrant vers l'ext. T-bracket with screw outside opening window T-Verbinder mit Schraube ausßen öffnendes Fenster	Tope Unión con tornillo apertura exterior  Lacznik teowy skrecany do okien otwieranych na zewnątrz Cavallotti conuiti ap est.
	Testen uitgevoerd door instituut IBS (Oostenrijk) volgens norm Ö B 3800/3850 Essais effectués par IBS(Autriche) conformément la norme Ö B 3800/3850 Tests carried out by IBS (Austria) according to standard Ö B 3800/3850 Brandschutzprüfungen durch- geführt beim IBS (Österreich) gemäß Norm Ö B 3800/3850	Ensayos hechos por IBS (Austria) según la estandar Ö B 3800/3850 Badania wykonane przez IBS (Austria) według norm Ö B 3800/3850 Testato presso IBS (Austria) IBS secondo Ö B 3800/3850		Vulhoek Equerre de remplissage Corner support Fülleckwinkel	Escuadra de relleno Wspornik narozny Squadrette di riempimento
	Testen uitgevoerd door instituut TNO (Nederland) volgens norm NEN 6069:1997 Essais effectués par TNO (Hollande) conformément la norme NEN 6069:1997 Tests carried out by TNO (The Netherlands) according to standard NEN 6069/1997 Brandschutzprüfungen durch- geführt beim IBS (Österreich) gemäß Norm Ö B 3800/3850	Ensayos realizados fuera por TNO(Holanda) según norma NEN 6069/1977 Badania wykonane przez TNO (Holandia) według norm NEN 6069/1977 Testato presso TNO (Paesi Bassi) secondo NEN 6069/1977		Verstelbare schroefhoek Equerre à visser réglable Adjustable screw corner cleat Verstellbarer Schraubewinkel	Escuadra de atornillar regulable Katowy naroznik skrecany Squadrette ad avvitare regolabili
	Testen uitgevoerd door instituut TNO (Nederland) volgens norm NEN 6069:1997 Essais effectués par TNO (Hollande) conformément la norme NEN 6069:1997 Tests carried out by TNO (The Netherlands) according to standard NEN 6069/1997 Brandschutzprüfungen durch- geführt beim IBS (Österreich) gemäß Norm Ö B 3800/3850	Ensayos realizados fuera por TNO(Holanda) según norma NEN 6069/1977 Badania wykonane przez TNO (Holandia) według norm NEN 6069/1977 Testato presso TNO (Paesi Bassi) secondo NEN 6069/1977		Steenhoeken verstelbaar Cales de feuillure réglables Rebate supports adjustable Verstellbare Eckwinkel Glasanschlag	Escuadra de alineamiento regulable Katowy naroznik nastawny Squadrette di allineamento regolabile
	Brandwerend Anti-feu Fire-proof Feuerhemmend	Resistente al fuego Ognioodpome Anti fuoco		Hoekverbinding met nagel Equerre avec cheville Corner cleat with drive pin Eckverbinder mit Stift	Escuadra con clavia Lacznik narozny sworzniowy Squadrette a spinare
	Testen uitgevoerd volgens norm EN 1634-1(deuren) en EN 1364-1 (beglaasde wanden) Essais effectués par conformément la norme EN 1634-1(portes) et EN 1364-1(parois vitrés) Tests carried out according to standard EN 1634-1(doors) EN 1364-1(glazed partitioning) Prüfungen gemäß Norm EN 1634-1(Türen) und EN 1364-1(verglaste Wände)	Ensayos realizados según norma 1634-1/ EN 1364-1 - Badania wykonane według normy 1634-1 / EN 1364-1 - Antifuoco secondo EN 1634-1 / EN 1364-1 -		T-verbinding met nagel Jonction-T avec cheville T-bracket with drive pin T-Verbinder mit Stift	Tope de union con clavia Lacznik teowy sworzniowy Cavalotto a spinare
	Testen uitgevoerd volgens norm EN 1634-1(deuren) en EN 1364-1 (beglaasde wanden) Essais effectués par conformément la norme EN 1634-1(portes) et EN 1364-1(parois vitrés) Tests carried out according to standard EN 1634-1(doors) EN 1364-1(glazed partitioning) Prüfungen gemäß Norm EN 1634-1(Türen) und EN 1364-1(verglaste Wände)	Ensayos realizados según norma 1634-1/ EN 1364-1 - Badania wykonane według normy 1634-1 / EN 1364-1 - Antifuoco secondo EN 1634-1 / EN 1364-1 -		T-verbinding met nagel voor buitendraaiend raam Jonction-T avec cheville pour fenêtre ouvrant vers l'ext. T-bracket with drive pin outward opening window T-Verbinder mit Stift nach ausßen öffnendes Fenster	Tope unión con clavia apertura exterior  Lacznik teowy sworzniowy do okien otwieranych na zewnątrz Cavalotto a spinare ap. est.
	Toebehoren brandwerend Accessoires anti-feu Fire-proof accessories Feuerhemmender Zubehör	Accesorios resistente al fuego Aksesoria ognioodpome Accessori Anti fuoco		Verstelbare T-verbinding Jonction-T réglable Adjustable T-bracket Verstellbarer T-Verbinder	Union T regulable Lacznik teowy nastawny Giunti a T regolabili
	Gelaagd glas Verre feuilleté Laminated glass Verbundglas	Vidrio Laminado Szyba laminowana Vetro laminato		Kruisverbindingen Jonctions transversales Cross connections Kreuzverbindungen	Uniones transversales Polaczenie krzyzowe Collegamento a croce
	Glas Verre Glass Glas	Vidrio Szyba Vetro		Kruisverbinding met schroef Jonction transversale avec vis Cross connection with screw Kreuzverbindung mit Schraube	Union transversal con tornillo Polaczenie krzyzowe skrecane Collegamento a croce con viti
	Handleiding Manuel Manual Gebrauchsanweisung	Manual Instrukcja Manuale		Bevestiging drager Fixation chevon Fixation rafter Befestigung Dachsparren	Fijacion mainel Mocowanie krokwi Fissaggio montante
	Alleen voor CS 59 Seulement pour CS 59 Only for CS 59 Nur für CS 59	Solo para CS 59 Tylko do CS 59 Solo per CS 59			
	Alleen voor CS 68 Seulement pour CS 68 Only for CS 68 Nur für CS 68	Solo para CS 68 Tylko do CS 68 Solo per CS 8			
	Alleen voor CS 77 Seulement pour CS 77 Only for CS 77 Nur für CS 77	Solo para CS 77 Tylko do CS 77 Solo per CS 77			





























	Eénpuntsluiting Fermeture à 1 point 1-Point lock Einfachverriegelung	Cerradura de 1 punto Zamek 1-punktowy Serratura a 1 punto di chiusura		Elektrische deurpener Gâche pour serrure électrique Electric door opener Elektrischer Türöffner	Portero automatico Elektrorygiel Apertura porta elettrica
	Eénpuntsluiting met dagschieter Fermeture à 1 point à pêne 1-Point lock with latch Einfachverriegelung mit Falle	Cerradura 1 punto golpe Zamek 1-punktowy Serratura a 1 punto di chiusura con scrocco		Deurgrendels en kantschuiven Verrous de condamnation portes Flush and door bolts Kantriegel und Türriegel	Pasadores puerta Rygle biemych skrzydel drzwiowych Catenacciolo chiusura centrale
	Eénpuntsluiting met rol Fermeture à 1 points à rouleau 1-Point lock with roller Einfachverriegelung mit Rolle	Cerradura de 1 punto con rodillo Zamek 1-punktowy z barylka Serratura a 1 punto di chiusura con rullino		Geen elektrische spanning bij gesloten deur En cas de porte fermé pas des tension électrique No electric tension in case of closed door Keine elektrische Spannung bei geschlossen Tür	<b>Sin tensión eléctrica en caso de que la puerta esté cerrada</b> Brak elektrycznego napiecia w przypadku zamkniętych drzwi Stacco tensione a porta chiusa
	Haakslot Serrure à crochet Hook lock Hakenschluss	Cerradura gancho Zamek hakowy Serratura a gancio		Keine elektrische Spannung bei geschlossen Tür	
	Tweepuntsluiting Fermeture à 2 points 2-Point lock Zweifachverriegelung	Cerradura de 2 puntos Zamek 2-punktowy Serratura a 2 punti di chiusura		Raampompen Crémones Window handles Handhebel	Cremona Klamka okienna Cremonese
	Driepuntsluiting Fermeture à 3 points 3-Point lock Dreifachverriegelung	Cerradura de 3 puntos Zamek 3-punktowy Serratura a 3 punti di chiusura		Deurkrukken Béquilles Door handles Türdrücker	Manubrios Klamka drzwiowa Maniglie
	Driepuntsluiting met rol Fermeture à 3 points à rouleau 3-Point lock with roller Dreifachverriegelung mit Rolle	Cerradura de 3 puntos con rodillo Zamek 3-punktowy z barylka Serratura a 3 punti di chiusura con rullino		Sluitingen dubbele deur Serrures pour porte double Locks for double door Türbriegel	Cerradura puerta doble Blokada drzwi dwuskrzydlowych Serratura porta a 2 ante
	Vierpuntsluiting Fermeture à 4 points 4-Point lock Vierfachverriegelung	Cerradura de 4 puntos Zamek 4-punktowy Serratura a 4 punti di chiusura		Raampomp naar buiten draaiend raam Crémone fenêtre ouvrant vers l'extérieur Handle outward opening window Handhebel nach aussen öffnendes Fenster	Cremona ventana apertura exterior Klamka okna otwieranego na zewnątrz Cremonese apertura est.
	Vijfpuntsluiting Fermeture à 5 points 5-Point lock Fünffachverriegelung	Cerradura de 5 puntos Zamek 5-punktowy Serratura a 5 punti di chiusura			
	Vijfpuntsluiting met rol Fermeture à 5 points à rouleau 5-Point lock with roller Fünffachverriegelung mit Rolle	Cerradura de 5 puntos con rodillo Zamek 5-punktowy z barylka Serratura a 5 punti di chiusura con rullino		Raamscharnieren Paumelles pour fenêtres Window hinges Fensterbänder	Bisagras ventana Zawias okienny Cerniere
	Zespuntsluiting Fermeture à 6 points 6-Point lock Sechsfachverriegelung	Cerradura de 6 puntos Zamek 6-punktowy Serratura a 6 punti di chiusura		Deurscharnieren 2-delig Paumelles porte 2-partite Door hinges 2-part Türbänder 2-teilig	Pernio puerta 2 palas Zawias drzwiowy 2-czesciowy Cerniera 2 ali
	Zevenpuntsluiting Fermeture à 7 points 7-Point lock Siebenfachverriegelung	Cerradura de 7 puntos Zamek 7-punktowy Serratura a 7 punti di chiusura		Deurscharnieren 3-delig Paumelles porte 3-partite Door hinges 3-part Türbänder 3-teilig	Pernio puerta 3 palas Zawias drzwiowy 3-czesciowy Cerniera 3 ali
	Espagnoletslot Fermeture espagnolette Espagnolette Lock Treibriegelverschluss	Cierre ventana Zamek drzwiowy do blokady pionowej Serratura a spagnoletta		Afstandsbusen Pièces de distance Set of distance bushes Distanzbuchsen	Piezas distanciadoras Tuleje dystansowe Set distanziali
	Cilinders Cylindres Cylinders Zylinder	Bombines Cylindry Cilindri		Geen afstandsbusen nodig Pas de pièces de distance No distance bushes needed Keine Distanzbuchse	No necesario piezas distanciadoras Brak koniecznosci stosowania tuleji dystansowych Senza distanziali
	Cilinderplaten Ecussons Cylinder covers PZ-Rosette	Escudos bombin Oslona wkładki bebenkowej Copertura cilindri		Inbraakwerende kogel Bille anti-vol Anti-burglar ball Einbruchhemmende Kugel	Bola proteccion antirobbo Kulka antywłamaniowa Anticasso
	Slotpads Gâches Receivers Schliessbleche	Gancho Gniazdo rygla zamka Riscontri		Dieveklauw Pene anti-degondage Anti-lift pin Sicherheitsbolzen	Perno antielevador Bolec antywyważeniowy Antisollevamento
	Deursluiters Ferre-porte Door closer Türschliesser	Cierrapuertas Samozamykacz drzwiowy Chijdiporta		Kozjindorpelveer Pivot de frein aerien Overhead closer Obentürschliesser	Muelle aereo Samozamykacz gorny Chiudi porta sup.
				Vloerveer Pivot de frein au sol Floor closer Bodentürschliesser	Muelle pavimento puerta Samozamykacz podlogowy Chiudi porta inf.

	Eindstuk deurvleugel Pièce finale ouvr. porte End piece door vent Endkappe Türflügel	Tapeta hoja puerta Koncowka do skrzydła drzwiowego Terminale anta		Binnenbeglazingsdichtung Joint à bourrer Inner glazing gasket Innenverglasungsdichtung	Junta de acristalado interior Uszczelka przyszybowa wewnętrzna Guarnizione del vetro interna
	Eindstukken bodemprofiel Pièces finales profilé de seuil End pieces floor profile Endkappe Schwelle	Piezas terminales perfil suelo Koncowki profilu podlogowego Terminale soglia		Buitenbeglazingsdichtung Joint de vitrage extérieur Outer glazing gasket Aussenverglasungsdichtung	Junta de acristalado exterior Uszczelka przyszybowa zewnętrzna Guarnizione del vetro esterna
	Eindstukken Z-T deur Bouchon profilé porte Z-T End pieces Z-T door Endkappe Z-T Tür	Tapetas puerta Z-T Element koncowy Z-T drzwi Terminale profili porte Z e T		Buitenbeglazingsdichtung Joint de vitrage extérieur Outer glazing gasket Aussenverglasungsdichtung	Junta de acristalado exterior Uszczelka przyszybowa zewnętrzna Guarnizione del vetro esterna
	Afdichtingen dorpels Profils latéral pour bavettes Sill end pieces Endstück für Wetterschenkel	Tapetas condensacion Koncowki do profili podokiennych Tappi soglia		Akoestische dichting Joint acoustique Acoustical seal gasket Flügelanschlagdichtung	Junta acustica Uszczelka akustyczna Guarnizione di isolamento acustico
	Glassteunen Supports cale de vitrage Glazing supports Klotzbrücken	Soportes vidrio Podporka pod przeszklenie Supporti per vetro		Middendichtingen Joints centraux Central gaskets Mitteldichtungen	Junta central Uszczelka centralna Guarnizione centrale
	Afdekkap voor waterafvoersleuven Capuchon écoulement d'eau Weep hole cover Abdeckkappe Entwässerung	Deflector aire Maskownica otworu drenazowego Paratempesta		Aanslagdichtung Joint de butée Butt strip Anschlagdichtung	Junta tope Uszczelka Guarnizione di battuta
	Eindstukken stolprofielen Bouchons double ouvrant End parts double casement profile Endkappe Stulpprofil	Tapetas perfil doble hoja Koncowka profilu ruchomego slupka Tappo inversione		Dilatatie dichtingen Joints de dilatation Expansion gaskets Dehnungsdichtungen	Junta de dilatacion Uszczelka dylatacyjna Guarnizione di espansione
	Koppelstuk Pièce de raccordement Connection piece Kopplungsstueck	Pieza de union Element łączący Accessori collegamento		Dichting Joint Gasket Dichtung	Junta Uszczelka Guarnizione
	Eindstukken voor stolprofielen Bouchons pièce finale pour profilé double ouvrant End parts for double casement profiles Endkappen für Stulpprofile	Tapeta perfil doble hoja Koncowka profilu ruchomego slupka Tappi 2 ante		Dichting Joint Gasket Dichtung	Junta Uszczelka Guarnizione
	Afdichting goot Fermeture gouttière End piece gutter Endkappe Rinne	Tapetas canal Koncowka rynny Terminale gronda		Afdichtingsstuk Pièce d'étanchéité Sealing piece Dichtstück	Pieza de sellado Element uszczelniający Accessorio per sigillatura
	Opzwellende Dichting Joint Gonflant Swelling Gasket Schwellende Dichtung	Junta veranda Uszczelka do werandy Guarnizione espansione		Afdichting goot Fermeture gouttière End piece gutter Endkappe Rinne	Tapetas canal Koncowka rynny Terminale gronda
	Eindstuk Pièce finale End piece Endkappe	Terminal Koncowka Terminale		Dichting veranda Joint véranda Gasket veranda Dichtung Wintergarten	Junta veranda Uszczelka do werandy Guarnizione veranda
	Stootplaat Arrêt vitrage toiture Glass panel stop Endstück Verglasung	Tope del panel de vidrio Ogranicznik wypełnienia Ferro x vetro		Borsteldichtingen Joints brosse Brushes Bürstendichtungen	Cepillos Szczotki Spazzole
	Veranda type 1 Veranda type 1 Veranda type 1 Veranda Typ 1	Veranda tipo 1 Weranda typu 1 Veranda tipo 1		Isolerend vulstuk Pièce de remplissage isolante Insulating filling piece Isolierendes Füllstück	Pieza de relleno aislante Wkładka izolacyjna Riempimento isolanta
	Paniekdeur Porte de panique Panic door Paniktür	Puerta antipánico Drzwi antypaniczne Porta antipanico		Einddichting Joint d'assemblage End gasket Enddichtung	Junta Uszczelka koncowka Angolo prestampato
	Diversen Divers Miscellaneous Diverse	Diversos Elementy uzupełniające Varie		Isolatie Isolant Insulation Isolation	Aislamiento Izolacja Isolante
	Klemstuk Clip Clip Federklemme	Clip Uchwyt Clip		Brievenkleppen Entrées de courrier Letter boxes Briefeinwurf	Buzones Skrzynka na listy Cassetta posta
	Nokbevestiging Fixation de la faîtière Fixation of the ridge Firstanschluss	Fijacion del resalte Element mocujący kalenicowy Fissaggio colmo		Automatische deur dichtingen Fermetures automatiques Automatic door latches Automatische Türdichtungen	Cierrapuertas automaticos Drzwiowa automat. opadająca listwa Dispositivo di chiusura soglia
	Variant Variante Variant Variante				Variant Variante Variant Variante



	Stolp-kipraam Fenêtre double ouvr.-batt. Double casem.-tilt window Stulpfenster D/DK	Ventana abatible doble hoja Okno rozwierano-uchylne dwuskrzydlowe Finestra a 2 ante ribalta		DRAAISCHUIFFRAAM OUVRANT PROJÉTANT SIDE-HUNG SLIDING WINDOW DREHSCHIEBEFENSTER
	Draaikip Oscillo-battant Turn and tilt Drehkip	Oscilobatiante Okno rozwierno-uchylne Anta ribalta		
	Kipdraai Battantes-ouvrantes Tilt and turn Kippdreh	Batiante oscilante Okno uchylno-rozwierane Anta ribalta inversa		
	Draairaam Fenêtre ouvrante Side-hung window Drehfenster	Ventana practicable Okno rozwierane Battente		
	Stolpraam Fenêtre double ouvrant Double casement window Stulp-Flügel Fenster	Ventana doble hoja Okno rozwierane wuskrzydlowe Finestra a 2 ante		
	Valraam Fenêtre à soufflet Bottom hung window Kipp-Fenster	Ventana abatible Okno uchylne Wasistas		
	Afstandbedieningen valraam Commandes à distance pour fenêtre à soufflet Remote control for fanlight window Oberlichtbeschlag für Kipp-Flügel	Funcionamiento a distancia para ventana de techo Mechanizm do dystansowego uchylania okien Vasistas con telecomando		
	Buitendraaiend raam Fenêtre ouvrant vers l'extérieur Outside opening window Nach aussen öffnendes Fenster	Ventana apertura exterior Okno otwierane na zewnątrz Finestra ad apertura esterna		Verankeringen Ancrages Fixing lugs Verankerungen
	Uitzetakraam Châssis à l'italienne Top-hung window Senk-Klappfenster	Ventana proyectante con compas Okno wychylne na zewnątrz Sporgere con frizioni		Sluitpennen en sluitstukken Rouleaux et gâches Lock pins and lock plates Schliesslerollen und Schliessstücke
	Tuimel- en taatsraam Châssis pivotant Pivot window Schwingflügel	Ventana pivotante Okno obrotowe Bilico		Goot Gouttière Gutter Rinne
	Voudeur Porte pliante Folding door Falttür	Puerta plegable Drzwi harmonijkowe Veranda libro		Dakvenster Tabatière Attic window Dachfenster
	Schuifkip (TF) Couissant-tombant (TF) Slide and tilt (TF) Schiebekipptür (TF)	Paralela Uchylno-przesuwny Scorrevole parallelo		Kunststof dakbedekking Toiture synthétique Synthetic roofing Kunststoff Dachdeckung
	Schuifraam Fenêtre coulissante Sliding window Schiebefenster	Ventana corredera Okno przesuwne Scorrevole		Zelfklevende dubbelzijdige tape Bande autocollante 2 faces Self-adhesive double sided tape Selbstklebendes beidseitiges Band
	Parallel opengaand raam Fenêtre ouvrant parallele Parallel opening window Parallelausstellfenster	Ventana proyectante paralela Okno rownoległe wysuwane na zewnątrz Sporgere parallelo		Domotica Domotique Domotics Domotik
	Kipraam Fenêtre battante Tilt window Kippfenster	Oscilo Okno uchylne Vasidas		Profielen met hoge isolatiewaarde Profils avec valeur d'isolation élevée Profiles with high insulation value Profile mit hohen Isolationswert
	Dubbele deur buitendraaiend Porte double ouvrant vers l'ext. Double door outward opening Zweiflügelige Tür aussen öffnend	Puerta doble apertura exterior Drzwi dwuskrzydlowe otw. nazew. Porta due ante apertura esterna		Wielen Galets Rollers Laufwagen
	Deur binnendraaiend Porte ouvrant vers l'int. Door inward opening Tür nach innen öffnend	Puerta apertura interior Drzwi otw. do wewnątrz Porta apertura interna		Regeltringels Triangles de réglage Adjustment rods Regulierstange
	Deur buitendraaiend Porte ouvrant vers l'ext. Door outward opening Tür aussen öffnend	Puerta apertura exterior Drzwi otw. na zewnątrz Porta apertura esterna		Geleidingsplaat Guide Guide plate Führung
				Anclajes Kotwy Ancoraggio
				Bulones y cerraderos Płytki i kolek ryglujacy -
				Canal Rynna Gronda
				Ventana de techo Okno dachowe Lucernario
				Cubierta en material sintético Wypelnienie poliweglanem na dachy Pannelo
				Cinta autoadhesiva de dos caras Biadesivo
				Domótica Domótica Domótica -
				Perfiles alto aislamiento térmico Profile o wysokiej izolacyjności termicznej Alto isolarento
				Ruletas Wozki Carrelli
				Varilla de ajuste Listwy regulacyjne Astina
				Placa guia Element naprowadzajacy Guida

	Gereedschap Outillage Tool Werkzeug	Util Narzędzie Utensile		Hydropneumatische pers Presse hydropneumatique Hydropneumatic press Hydropneumatische Presse	Prensa neumática Prasa hydropneumatyczna Pressa idropneumatica
	Gereedschappen en machines voor ontwatering van kader Outillage et machinerie pour drainage dormant Tools and machinery for draining outer frame Werkzeuge und Maschinen für Entwässerung Blendrahmen	Utiles y maquinaria para el drenaje del marco Narzędzia i maszyny do drenazy osiecznic Utensili e macchinari per il drenaggio del telaio		Zaagmachine Tronçonneuse Sawing machine Kreissäge	Maquina de corte Pila do cieć przestrzennych Macchina per taglio
	Gereedschappen en machines voor ontwatering van vleugel Outillage et machinerie pour drainage ouvrant Tools and machinery for draining vent Werkzeuge und Maschinen für Entwässerung Flügel	Utiles y maquinaria para el drenaje de la hoja Narzędzia i maszyny do drenazy skrzydeł Utensili e macchinari per il drenaggio dell'anta		Hoekpers Sertisseuse Crimper Eckverbindungsmaschine	Ensambladora Zaciskarka narozy Cianfrinatrice
	Gereedschappen en machines voor T-verbinding Outillage et machinerie pour jonction-T Tools and machinery for T-brackets Werkzeuge und Maschinen für T-Verbinder	Utiles y maquinaria para topes de unión Narzędzia i maszyny do polaczen teowych Utensili e macchinari per i giunti		Handmatris Matrice manuelle Manual punch tool Handstanzwerkzeug	Prensa manual Wykrojnik ręczny Punzonatrice manuale
	Gereedschappen en machines voor kruikuitsparing Outillage et machinerie pour fermeture Tools and machinery for closure Werkzeuge und Maschinen für Beschläge	Utiles y maquinaria para el cierre Narzędzia i maszyny do zamknięc Utensili e macchinari per le chiusure		Gereedschap voor lijninjectie Outillage pour encollage Tool for injection Werkzeug fuer Klebeinjektion	Util para inyeccion Narzędzie do wtrysku kleju Utensile colla
	Gereedschappen en machines voor kruikuitsparing Outillage et machinerie pour fermeture Tools and machinery for closure Werkzeuge und Maschinen für Beschläge	Utiles y maquinaria para el cierre Narzędzia i maszyny do zamknięc Utensili e macchinari per le chiusure		Gereedschap voor krukken Outillage pour cremones Tool for handles Werkzeug fuer Handhebel	Util para manetas Narzędzie do klamek Utensile per maniglie
	Gereedschappen en machines voor kruikuitsparing Outillage et machinerie pour fermeture Tools and machinery for closure Werkzeuge und Maschinen für Beschläge	Utiles y maquinaria para el cierre Narzędzia i maszyny do zamknięc Utensili e macchinari per le chiusure		Gereedschap voor sluitlatten Outillage pour tringles Tool for linkbars Werkzeug fuer Schubstange	Util para barras union Narzędzie do listew sterujacych okuciami Utensile per barre di collegamento
	Gereedschappen en machines voor kruikuitsparing Outillage et machinerie pour fermeture Tools and machinery for closure Werkzeuge und Maschinen für Beschläge	Utiles y maquinaria para el cierre Narzędzia i maszyny do zamknięc Utensili e macchinari per le chiusure		Gereedschap voor T-verbindingen Outillage pour connections-T Tool for T-connections Werkzeug fuer T-Verbindungen	Util para topes de union Narzędzie do polaczen Teowych Utensile per travesi
	Multifunctionele matris Matrice multifonctionnelle Multifunctional punch tool Mehrzweckstanzwerkzeug	Matriz multifuncional Wykrojnik wielofunkcyjny Punzonatrice multifunzionale		Klemblokken Blocs de serrage Clamping blocks Spannbacken	Bloques de presión Blokli zaciskowe Blocchetti di supporto
	Geleide matris Matrice guidée Punch tool Stanzwerkzeug	Matriz Wykrojnik Punzonatrice		Gereedschap voor ontwatering buitenkaders Outillage pour drainage dormants Tool for drainage outer frames Werkzeug fuer Entwässerung Blendrahmen	Util drenaje marco Narzędzie do drenazy osiecznic Utensile per drenaggio telaio
	Handmatig gereedschap Outillage manuel Manual tools Handwerkzeuge	Util manual Narzędzie ręczne Dime		Gereedschap voor hoekverbinding Outillage pour connection d'equerre Tool for corner connection Werkzeug fuer Eckverbindung	Util union esquina Narzędzie do polaczen narozynych Utensile per connessioni d'angolo
	Freessjabloon Calibre de fraisage Stencil plate for milling head Fräseschablone	Plantilla para copiadora Szablon do frezarki Maschera per pantografo		Gereedschap voor montage Outillage pour montage Tool for assembly Werkzeug fuer Montage	Util para colocacion Narzędzie do montazu Utensile assemblaggio
	Enkelkopse freesmachine Frais. à copier à une broche Copy router 1 spindle Einspindel-Kopierfräse	Copiadora de un cabezal Frezarka z jedna głowica Pantografo di copia a 1 mandrino 1 mandrino		Gereedschap voor deursluiters Outillage pour fermeture porte Tool for door closer Werkzeug fuer Türschliesser	Util para cierrapuertas Narzędzie do samozamykacza drzwiowego Utensile chiu di porta
	Frees- en boormachine Fraiseuse et foreuse Router and drilling machine Fräse- und Bohrerät	Copiadora taladradora Frezarka z wiertarka Centro dilavoro		Gereedschap voor scharnieren Outillage pour charnieres Tool for hinges Werkzeug fuer Bänder	Util para bisagras Narzędzie do zawiasy Utensile cerniere
				Gereedschap voor sloten Outillage pour fermetures Tool for locks Werkzeug fuer Schlösser	Util para cerraduras Narzędzie do zamka Utensile serrature
				Gereedschap voor wisselprofielen Outillage pour chicanes Tool for sections Werkzeug fuer Wechselprofile	Util para encuentros centrales Narzędzie do przekrojow Utensile chicanes
				Gereedschap voor beglazing Outillage pour vitrage Tool for glazing Werkzeug fuer Verglasung	Util para acristalamiento Narzędzie do przeszklen Utensile vetro
				Gereedschap voor diverse toepassingen Outillage pour applications divers Tool for miscellaneous applications Werkzeug fuer diverse Anwendungen	Utiles para varias aplicaciones Narzędzie do montazu elementow uzupełniajacych Utensile vari

	Gereedschap voor dichtingen Outillage pour joints Tool for gaskets Werkzeug für Dichtungen	Util para juntas Narzędzie do uszczelki Utensile guarnizioni		Pneumatische aandrijving Propulsion pneumatic Pneumatic drive Pneumatische Antrieb	Destornillador neumático Pneumatyczny naped Cilindro pneumatica
	Gereedschap voor bevestiging wielen Outillage pour fixation des roulettes Tool for fixation rollers Werkzeug für Befestigung Laufräder	Util para fijación de ruletas Narzędzie do montazu wozkow Utensile carrelli		Ponsunit Unité d'étamper Punch unit Stanzeinheit	Punzon Wykrojnik Unita punzonatrice
	Gereedschap voor ontwatering vleugels Outillage pour drainage ouvrants Tool for drainage vents Werkzeug für Entwässerung Flügel	Util para drenaje hoja Narzędzie do drenazu skrzydla Utensile drenaggio anta		Land Pays Country Land	Pais Kraj Nazione
	Uitfrezing voor inbouw bovenspeun in kozijn Fraisage pour encastrement gond supérieur dans la fenêtre Milling for building in upper pivot in window Ausfräsung für Einbau eines oberen Lagers im Rahmen	Fresado para pivotante en marco superior Frez do montazu gornego sworznia w oknie Lavorazioni super. finestra pivotante		Min. profiellengte Longueur min. de profilé Min. length of profile Min. Profillänge	Longitud mínima del perfil Minimalna dlugosc profilu Lunghezza minima profilo
	Uitfrezing voor inbouw vloerspeun in vleugel Fraisage pour encastrement gond inférieur dans l'ouvrant Milling for building in floor pivot in vent Ausfräsung für Einbau eines Bodenlagers im Flügel	Fresado para pivotante en hoja inferior Frez do montazu dolnego sworznia w skrzydle Lavorazioni infer. finestra pivotante		Max. profiellengte Longueur max. de profilé Max. length of profile Max. Profillänge	Longitud máxima del perfil Maksymalna dlugosc profilu Lunghezza max profilo
	Uitfrezing voor inbouw bovenspeun in vleugel Fraisage pour encastrement gond supérieur dans l'ouvrant Milling for building in upper pivot in vent Ausfräsung für Einbau eines oberen Lagers im Flügel	Fresado para pivotante en hoja superior Frez do montazu gornego sworznia w skrzydle Lavorazione super. finestra pivotante		Max. profielhoogte Hauteur max. de profilé Max. height of profiles Max. Profilhöhe	Altura máxima del perfil Maksymalna wysokosc profilu Max altezza
	Monteertafel Table de montage Assembly bench Montagetisch	Banco de montaje Stol montazowy Banco montaggio		Max. horizontale beweging Movement max. horizontale Max. horizontal movement Max. horizontale Versetzung	Movimiento horizontal máximo Maksymalny ruch poziomy Spostamento orizz. max
	Elektrische aansluiting Fixation électrique Electric connection Elektrisches Anschluss	Conexión eléctrica Polaczenie elektryczne Connessione elettrica		Horizontaal hoekbereik Intervalle d'équerre horizontale Horizontal corner range Eckbereich Horizontal	Rango de corte a inglete horizontal Zakres katow poziomych Dimensione taglio orizz.
	Compressor Compresseur Compressor Kompressor	Compresor Kompresor Compressore		Verticaal hoekbereik Intervalle d'équerre verticale Vertical corner range Eckbereich Vertikal	Rango de corte a inglete vertical Zakres katow pionowych Dimensione taglio vert.
	Kogel Dr. Hahn Bille Dr. Hahn Ball Dr. Hahn Kugel Dr. Hahn	Bola Dr. Hahn Kulka Dr. Hahn -		Motor Moteur Motor Antrieb	Motor Silownik napędowy Motore
	Monteertafel Table de montage Assembly bench Montagetisch	Banco de montaje Stol montazowy Banco montaggio		Gewicht Poids Weight Gewicht	Pesos Ciężar Peso
	Elektrische aansluiting Fixation électrique Electric connection Elektrisches Anschluss	Conexión eléctrica Polaczenie elektryczne Connessione elettrica		Max. toerental Vitesse d'axe max. Max. spindle speed Max. Drehzahl	Velocidad de sierra Maksymalna predkosc obrotowa Velocita max lama
	Compressor Compresseur Compressor Kompressor	Compresor Kompresor Compressore		Kogel Dr. Hahn Bille Dr. Hahn Ball Dr. Hahn Kugel Dr. Hahn	Bola Dr. Hahn Kulka Dr. Hahn -
	Mechanische aansluiting Fixation mecanique Mechanical connection Mechanischer Anschluss	Conexión mecánica Polaczenie mechaniczne Fissaggio meccanico		Mechanische aansluiting Fixation mecanique Mechanical connection Mechanischer Anschluss	Conexión mecánica Polaczenie mechaniczne Fissaggio meccanico



**B**



Algemene informatie systemen

Généralités séries

General Information System

Allgemeine Information System



# VERWERKINGSVOORSCHRIFTEN

## I. ALGEMEEN

Zie catalogus "1. Algemene informatie" (089.C01E.00 editie 11/2004)

## II. VERWERKINGSVOORSCHRIFTEN HFP 147

### II.1 CONSTRUCTIEVOORSCHRIFTEN

Om blijvend een perfect eindproduct te garanderen, dienen tijdens de verwerking bepaalde regels in acht genomen te worden.

#### II.1.1 Verspanende bewerkingen

Onder verspanende bewerkingen wordt verstaan: alle mechanische bewerkingen zoals zagen, frezen, boren ponsen en knippen. Voor gelakte profielen is het essentieel dat de laklagen aan de randen niet loskomen tijdens deze bewerkingen. Het is daarom van groot belang voor de kwaliteit van de verbindingen dat:

- Het verspanende gereedschap geschikt en voldoende scherp is.
- De machines goed afgeregeld zijn (bv. Toerental).
- Een regelmatige controle van het gereedschap gebeurt.
- Het verspanende gereedschap correct en voldoende gesmeerd wordt:
  - smeerstick Reynalube (art. Nr. 086.9191.UN) voor zaagbladen.
  - snijmiddel (art.nr. 086.9175.UN) voor ponsgereedschap.
  - of de door de machineleverancier voorgeschreven koel- en smeermiddelen.
- De gepaste klemblokken worden gebruikt. (zie montagetekening "klemblokken")
- De aan- en afvoertafel vrij zijn van spanen en verontreinigingen.
- Eventuele koeling gebeurt met chemische neutrale producten die de oppervlaktebehandeling niet aantasten.

#### II.1.2 Assemblage

Wij maken de volgende onderverdeling:

1. Hoekverbindingen;
2. Ontwatering en uitsparingen voor het beslag;
3. Dichtingen.

#### 1.2.1 Hoekverbindingen

Stappen:

- a. Keuze methode hoekverbinding (afhankelijk van beschikbare machines):
  - METHODE 1: Uithoeken zijkaderprofiel zijn 68mm diep (mogelijk met de meeste T-frezen, maar extra hulpstuk 062.9315.04 nodig om verbinding te maken tussen lage en hoge kaderprofielen).
  - METHODE 2: Uithoeking zijkaderprofiel is 100mm diep bij een verbinding met een hoge kader (mogelijk met uithoekzaag, maar misschien niet met T-frees, geen extra hulpstuk nodig)
- b. Correct zagen buitenkader-profiel
- c. Aanbrengen gaten buitenkader-profiel (□ 10mm; □ 5mm).
- d. Uithoeken buitenkader-profiel (hoogte in functie van de gekozen buitenkaderprofielen, en gekozen verbindingsmethode)
- e. Bescherming van de zaagsneden en bewerkte vlakken door:
  - Ontbramen (indien noodzakelijk);
  - Verwijderen van stof en zaagresten op de zaagsnede en in de profielkamer;
  - Ontvetten (Reynafinish 60 art. nr. 086.9210.--);
  - Aanbrengen van Reynaprotector (art. nr. 086.9208.SY + 086.9225.--) op zaagsnedes en Reynastick (art.nr. 086.9600.06) op de freessnedes.
- f. Afdichten van buitenkader-profiel door aanbrengen van een neutraal, elastisch dichtingmiddel:
  - Op de zaagsneden;
  - Op de bevestigingsgaten;
- g. De samengevoegde elementen dienen enkel aan de zichtvlakken gereinigd te worden van dichtingresten en dit uitsluitend met een niet-agressief middel (Reynafinish 60, art. nr. 086.9210.--).

### 1.2.2 Ontwatering, ontluchting en uitsparingen voor het beslag

Stappen:

- a. Aftekenen uitsparingen.
- b. Correct ponsen, boren of frezen.
- c. Beschermen van de bewerkte vlakken door:
  - Ontbramen (indien noodzakelijk).
  - Verwijderen van stof en zaagresten op de zaagsnede en in de profielkamer.
  - Ontvetten (Reynafinish 60 art. nr. 086.9210.--).
  - Aanbrengen van Reynastick (art. nr. 086.9600.06)

Aandachtspunten bij de ontwatering / ontluchting:

Eventueel binnendringend water moet vlot en gecontroleerd kunnen afgevoerd worden en de druk in de binnenkamers moet gelijk blijven aan die van de buitenlucht.

- Bij elk schuifelement worden er ontwateringsopeningen voorzien met een maximale afstand van 100mm van het uiteinde van het bodemprofiel van het buitenkader-profiel. De afstand tussen 2 ontwateringsopeningen bedraagt max. 800 mm.  
Per raamvak dienen min. 2 ontwateringsopening voorzien te worden!
- Alle types schuifelementen moeten voorzien zijn van een ontwateringsysteem in de onderregels.
- De minimale oppervlakte van deze ontwateringsopeningen bedraagt 50 mm<sup>2</sup> per opening in de kader/vleugel, hetzij een ronde opening van minimum 8 mm diameter, hetzij langwerpige openingen van minimaal 5 mm bij 15 mm. Voor het vast kader bedraagt de minimale oppervlakte 150 mm<sup>2</sup> per opening hetzij 3 ronde openingen van min. 8 mm diameter, hetzij een langwerpige opening van minimaal 8 mm bij 34 mm. , tenzij anders beschreven in de montagetekeningen.
- Ontwateringsgaten die aan de buitenzijde van het schuifelement zichtbaar zijn, worden afgedekt met kunststofkapjes, op het bovenste niveau zonder flapjes (artikel 069.6831.XX), op het onderste niveau met flapjes (artikel 069.6830.XX).
- Bij elk schuifelement worden er ontluchtingsgaten voorzien. De functie hiervan is de drukegalisatie rond de beglazing te waarboren.

Opmerking: Voor specifieke ontwateringen verwijzen wij naar bladzijde 25.F. ...

### 1.2.3 Dichtingen

Alle dichtingen zijn van weer- en verouderingsbestendig materiaal. De verwerking ervan dient zorgvuldig te gebeuren, aangezien hiervan de dichtheid van het schuifelement afhangt.

#### a. Het aanbrengen van de dichtingen.

Stappen:

1. Correct versnijden: Het versnijden van de dichting dient met een speciale schaar (art. nr. 090.0121.UN) te gebeuren. De dichting kan naargelang de soort profielverbinding in verstek of recht versneden worden. Benodigde overlengte (ca 10 mm per meter) dient voorzien te worden.
2. Aanbrengen dichting: de dichtingen worden aangebracht in de daarvoor voorziene groeven van de profielen. De overlengte wordt lichtjes opgestuikt om uitzetten of krimpen op te vangen. Moeilijkheden bij het inbrengen kunnen opgevangen worden met een siliconenspray (art. nr. 086.9551.--).
3. Verlijmen (afdichten): Naargelang de soort profielverbinding (recht) dient de dichting aan de uiteinden verlijmd te worden met secondenlijm (Reynaglu art. nr. 084.9106.--) . Deze verlijming is noodzakelijk om het uitglijden van de dichting te vermijden.

#### b. Het aanbrengen van de borsteldichtingen.

Stappen:

1. Correct versnijden: het versnijden van de borsteldichting dient met een speciale schaar (art. nr. 090.0121.UN) te gebeuren en de dichting kan naargelang van de soort profielverbinding in verstek of recht versneden worden.
2. Aanbrengen borsteldichting: de borsteldichtingen worden geschoven in de daarvoor voorziene groeven van de profielen.
3. Verlijmen: Naargelang de soort profielverbinding (recht) dient de borsteldichting aan de uiteinden verlijmd te worden met secondenlijm (Reynaglu art. nr. 084.9106.--) . Deze verlijming is noodzakelijk om het uitglijden van de borsteldichting te vermijden.

#### c. Het aanbrengen van een afdichting onder- en bovenaan het wisselprofiel.

Om een goede water- en winddichtheid te bekomen dient onder- en bovenaan het wisselprofiel een extra afdichting geplaatst te worden in het atelier:

- 2-rail / 3-rail schuifdeur (HFP 147 – HFP 179): onder- en bovenaan art. nr. 062.8081.04 + verlijmd met secondenlijm (Reynaglu art. nr. 084.9106.--) met 3x borstel (081.9135.SY)
- Het artikel verzorgt een afdichting tussen binnen en buiten, en moet aldus volledig gesiliconiseerd worden (onderkant en zijkanten) in het isolatie profiel.



- Dit onderdeel dient te worden geplaatst in de werkplaats om ervoor te zorgen dat de silicone volledig is uitgehard. Indien installatie gebeurt op de werf, dan kan dit onderdeel tijdens plaatsing van de andere onderdelen gaan verschuiven. Het plaatsen van de afdekkappen zal bijkomend helpen om 062.8081.04 op zijn plek te houden.
- Als er van dit stuk materiaal dient verwijderd te worden, bijvoorbeeld bij overlap met de fixatie blok, dan mag het 'vleugel' gedeelte nooit volledig verwijderd worden, om de wind en waterdichtheid van het systeem te blijven garanderen.

## II.2 MONTAGEVOORSCHRIFTEN

### II.2.1 Inbouw in de ruwbouw

Er wordt ten strengste afgeraden om Hi-Finity in agressieve milieus te plaatsen.

Hi-Finity werd ontwikkeld om een naadloze overgang mogelijk te maken tussen binnen en buitenzijde van het gebouw. Omwille hiervan worden de kader profielen ingebouwd in de vloer, de muren en het plafond. Voorbereiding van de bouwaansluiting is daarom cruciaal om de esthetische kwaliteit van het systeem te waarborgen. Het wil ook zeggen dat als constructeur, bij het opmeten en de fabricage van de opening voor dit systeem zeer nauwkeurig dient gewerkt te worden, om zo klein mogelijke toleranties mogelijk te maken, vooral dan in de diepte (om de verschillende delen van de kader mooi te laten aansluiten).

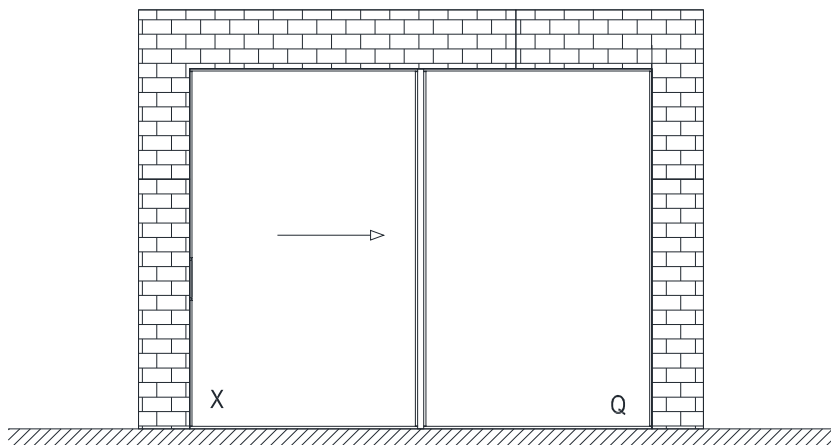

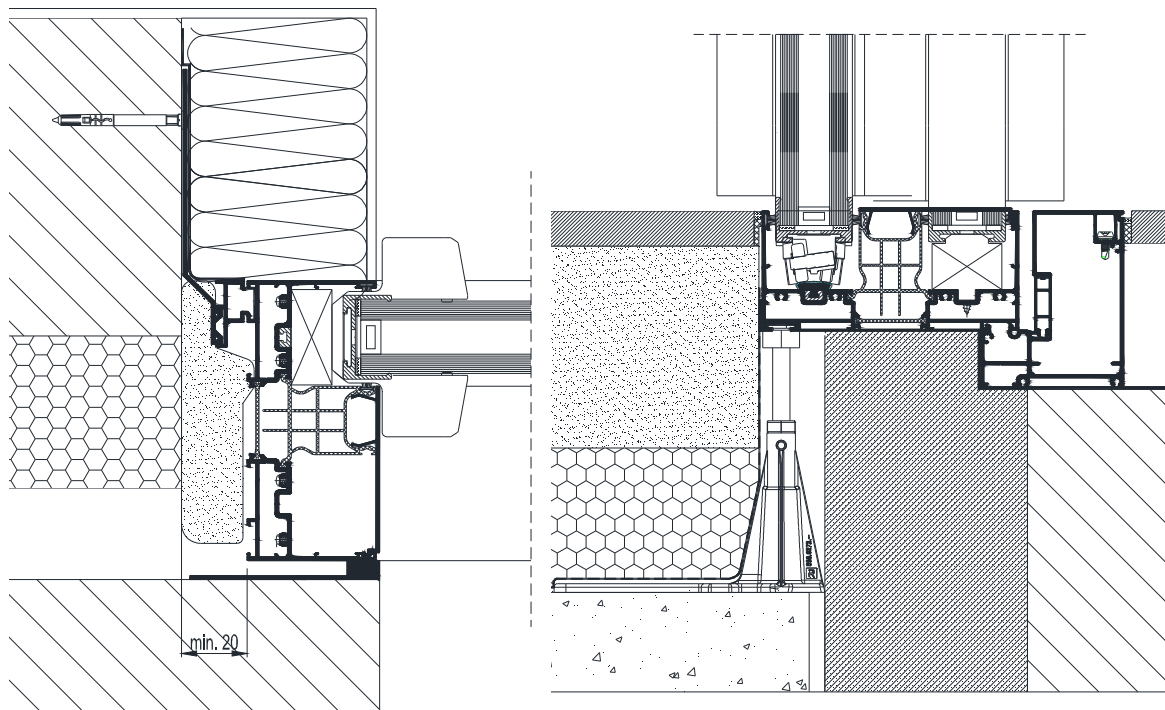

De verbinding tussen een structuur (terras) naar de kader kan gebeuren op 2 manieren:

- In het geval dat het terras niet waterdoorlatend is, dient er een goot geplaatst te worden om het water vooraan het systeem te evacueren. Deze goot kan naar onder of opzij afgewaterd worden.
- In het geval dat het terras waterdoorlatend is, of een waterdoorlatende structuur heeft, is het goot profiel niet nodig, en kan het terras worden aangebracht tot tegen het kader profiel.

De bovenzijde van het HFP system dient ook ingebouwd te worden in de facade van het gebouw. Deze facade wordt volgens geldende voorschriften ondersteund door een structuur, die bijkomende bescherming biedt naar de inbraakwerendheid van het systeem.

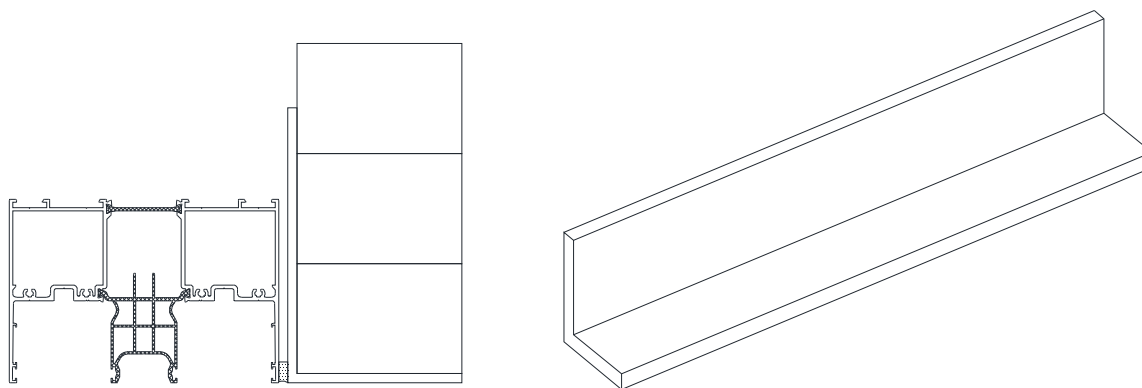

Het RC2 certificaat werd toegekend op basis van P4A glas (EN 356) en een ingebouwd system. Het systeem is ontwikkeld om een integraal deel uit te maken van het gebouw, en werd ook aldus uitvoerig getest. Als het element niet volgens deze voorschriften wordt toegepast, is het RC2 certificaat niet toepasbaar.

De bevestiging aan de ruwbouw gebeurt ofwel rechtstreeks doorheen de profielen met bijvoorbeeld schroeven en pluggen, ofwel met behulp van bevestigingsankers.

- De bevestigingen mogen niet minder dan 40 mm van de wand van de ruwbouw worden aangebracht.
- De verankering mag geenszins het draagvermogen van de aangrenzende bouwonderdelen beïnvloeden.
- Alle verankeringen, voor zover niet uit aluminium of roestvrij staal, dienen afdoende tegen corrosie te zijn beschermd en mogen zelf ook geen aantasting van het aluminium veroorzaken.
- Bij de plaatsing van de schuifelementen worden er voldoende bevestigingen voorzien:

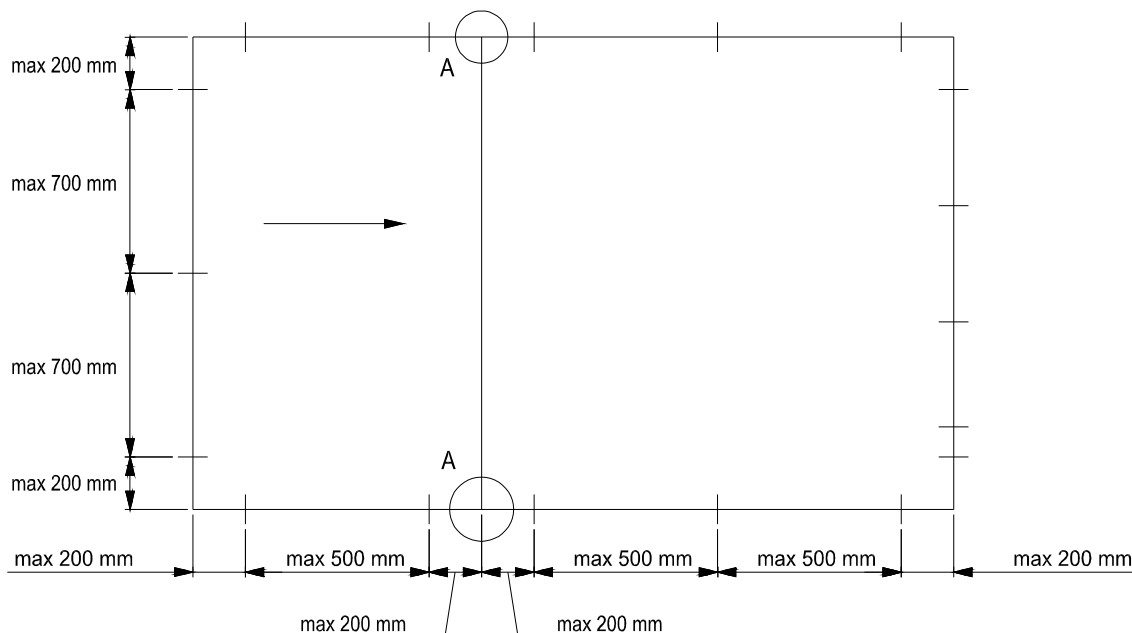

Er dienen aan alle zijden minstens 2 bevestigingen aangebracht te worden met een maximale afstand tot de hoek van 200 mm.

- De afstand van de bevestigingen onderling bedraagt maximum 700 mm (500 mm bij onderregel).
- Op de plaatsen waar de wisselprofielen tussen boven en onderregel zitten, moet de verankering op maximum 200 mm naast de center van de wisselprofielen worden aangebracht. (A).
- De onderregel moet te allen tijde ondersteund worden, om doorbuiging te voorkomen.

Opmerking: De verankeringen dienen dusdanig aangebracht te worden dat ze eventuele zettingen van het schuifelement kunnen opvangen.

Bij gebruik van schroeven en pluggen doorheen de profielen mogen de kamers in het onderste vaste kader niet doorboord worden om geen waterinfiltratie te bekomen ter hoogte van deze bevestiging.

## II.2.2 Inbouw van het beslag

De verlijmd glasplaat heeft een opening aan elke zijde voor het plaatsen van toebehoren. Na de installatie van de toebehoren en de profielen, zullen deze openingen niet meer zichtbaar zijn.

Meer informatie over de installatie en het afregelen van de toebehoren staat vermeld in de catalogoog, op de artikel website of in de documentatie die u kan terugvinden in de verpakking van het betreffende artikel.

Keuze van bevestigingspunten, aantal sluitpunten, max. vleugelgewicht, max. vleugelafmetingen, toegepast vleugelprofiel e.a. dient te gebeuren volgens de richtlijnen van de systeemleverancier en de beslagfabrikant.

Glijdende en bewegende delen zijn van neutraal vet te voorzien. Bij montage controleren of het beslag (inclusief elektronische componenten) soepel en zonder hapering te bedienen is.

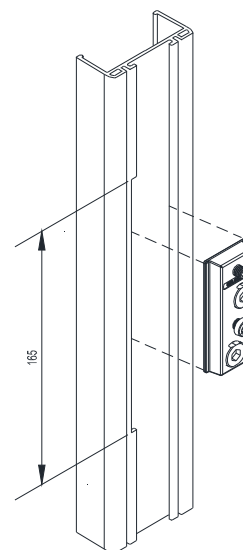

### II.3 BEGLAZING

De glasplaat wordt verlijmd met een composiet profiel door een door Reynaers gecertificeerde glas leverancier en besteld bij Reynaers aan de hand van een gestandaardiseerd bestel formulier. De verlijmd glasplaat heeft een opening aan elke zijde voor het plaatsen van toebehoren.

Wanneer een handgreep dient voorzien te worden (locatie voor deze handgreep kan aangegeven worden op het bestelformulier voor het Hi-Finity glas), wordt het composiet profiel onderbroken. Na het plaatsen van de handgreep wordt deze opening afgesloten met een afdek kap. Deze afdekkap moet geplaatst worden op de verlijmd glasplaat met een dichtingmiddel van Dow Corning (eg. DC895) of een equivalent product dat compatibel is met de lijm gebruikt voor het glas.

Er zijn verschillende types van glas selecteerbaar, afhankelijk van de gewenste te bouwen configuratie. Elk type kreeg een verschillende letter toegewezen om aldus communicatie te vereenvoudigen. (alle aanzichten hieronder zijn bekeken van buiten het gebouw)

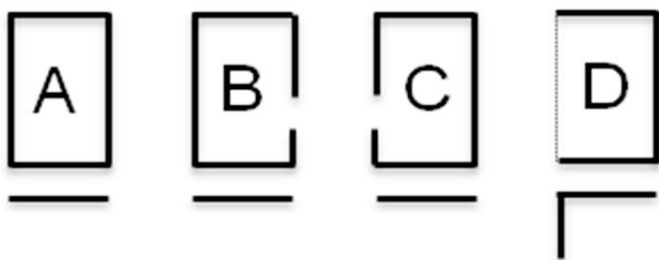

- A: glas zonder handgreep
- B: glas met handgreep aan de rechter zijde
- C: glas met handgreep aan de linkerzijde
- D: glas van een vaste hoek oplossing (voor beide zijden)

Afmetingen van het glas ten opzichte van afmetingen van het afgewerkte product:

Het bestel formulier verkregen via het Reynapro bestand geeft de maten weer van het glas voor het proces van structurele verlijming. De afmetingen vermeld in de catalogoog geven dezelfde afmetingen weer. Het afgewerkte glas, met het structureel verlijmd composiet profiel heeft grotere afmetingen dan het glas alleen. Om een bestelling bij levering te kunnen controleren kan u volgende richtlijnen volgen:

Voor type A, B of C:

- Voor HFP 147: glas afmetingen + 19 mm (zowel voor hoogte als breedte) +/- 1mm tolerantie

Voor type D (structurele verbinding van glas op glas):

- Een gedetailleerde tekening is vereist voor de bestelling
- Voor HFP 147: glas afmetingen + 19 mm (zowel voor hoogte als breedte) +/- 1mm tolerantie
- De glaspanelen worden op de werf verlijmd door de glasleverancier

Indien het glas niet binnen tolerantie geleverd werd, dient u uw Reynaers contactpersoon te verwittigen.



## III. MONTAGEVOLGORDE HFP 147

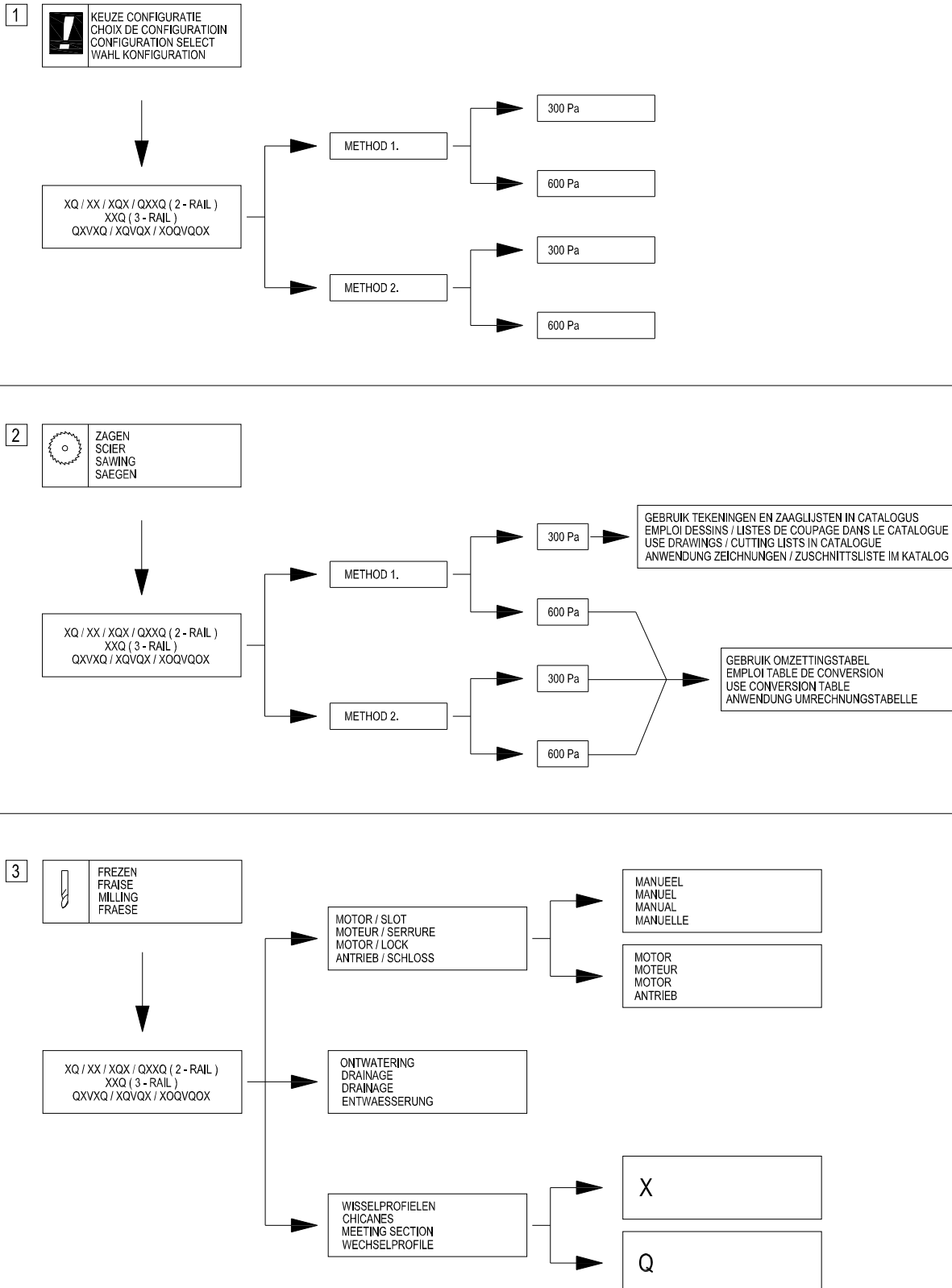

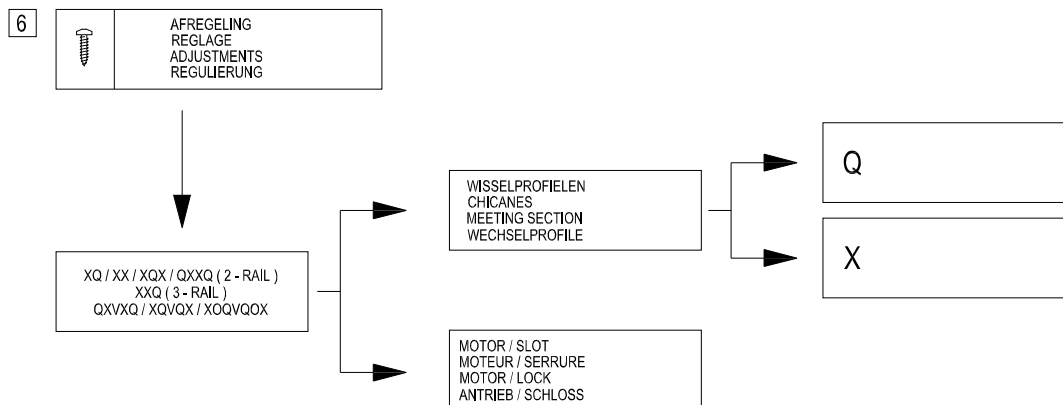
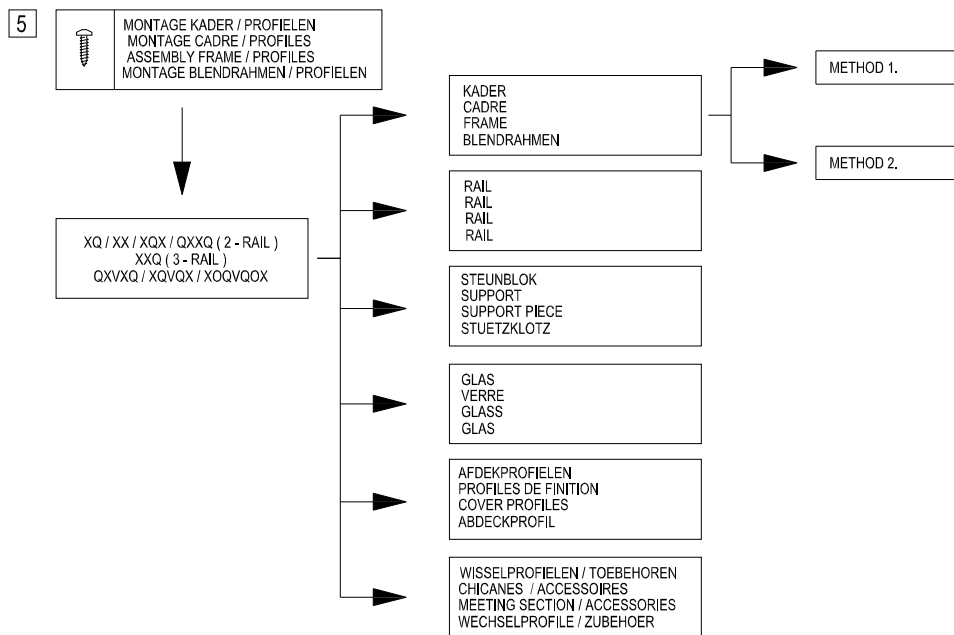
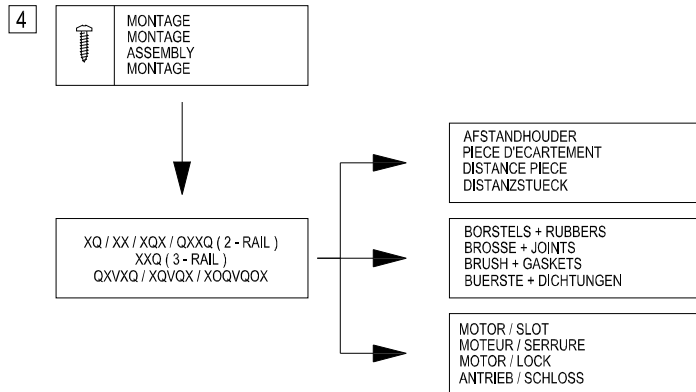





# RECOMMANDATIONS DE MISE EN OEUVRE

## I. GENERAL

Voir catalogue "1. Informations générales" (089.C01E.00 édition 11/2004)

## II. RECOMMANDATIONS DE MISE EN OEUVRE HFP 147

### II.1 RECOMMANDATIONS DE FABRICATION

Afin de garantir un produit final parfait, certaines règles doivent être suivies pendant la fabrication.

#### II.1.1 Opérations d'usinage

Par opérations d'usinage on entend: toutes les opérations mécaniques comme le tronçonnage, le fraisage, le forage, le poinçonnage et la découpe. Il est essentiel que la couche de laque des profils laqués ne se détache pas sur les bords pendant ces opérations.

Il est donc très important pour la qualité des assemblages que:

- Les outils d'usinage soient adaptés et suffisamment aiguisés;
- Les machines soient bien réglées (p.ex. régime);
- Un contrôle régulier des outils ait lieu;
- Les outils d'usinage soient correctement et suffisamment graissés:

bâton lubrifiant Reynalube (art. n°. 086.9191.UN) pour lames de scie.

huile de coupe (art. n°. 086.9175.--) pour outils de poinçonnage.

ou les réfrigérants et lubrifiants prescrits par les fournisseurs des machines.

- Les mors de serrage adaptés soient utilisés (voir détails de fabrication « blocs de serrage »);
- La table d'amenée ou d'évacuation soit exempte de copeaux et de souillures;
- Le refroidissement éventuel se fasse à l'aide de produits chimiquement neutres qui ne corrodent pas le traitement de surface.

#### II.1.2 Assemblage

Nous faisons la subdivision suivante:

1. Raccords d'angle
2. Drainage et découpes pour les accessoires;
3. Joints.

##### 1.2.1 Raccords d'angle

Étapes:

- a. Choisir méthode de jonction des coins (dépendant des machines disponibles):
  - METHODE 1: Les fraisages pour les jonctions des coins sont 68mm de profondeur (possible avec les fraiseuses jonction-T, mais il faut un article en plus 062.9315.04 pour arriver à faire la connexion entre un profil bas et un profil haut).
  - METHODE 2: Les fraisages pour les jonctions des coins sont 100mm de profondeur à la connexion d'un profil haut et bas (possible avec double scie, mais peut-être pas avec une fraiseuse jonction-T, article en plus n'est pas nécessaire pour faire la connexion)
- b. Tronçonnage correct du profilé du dormant.
- c. Réalisation des trous dans le profilé du dormant (□ 10 mm ; □ 5 mm).
- d. Tronçonnage du profilé du dormant (hauteur en fonction des profilés de dormant, et la méthode équerre choisie)
- e. Protection des coupes et des surfaces traitées par:
  - ébavurage (si nécessaire);
  - enlèvement des poussières et des copeaux de sciage sur la coupe et dans la chambre du profilé;
  - dégraissage (Reynafinish 60 art. n°. 086.9210.--)
  - application de Reynaprotector (art. n°. 086.9208.SY + 086.9225.--);
- f. Etanchement du profilé du dormant : appliquer de la matière d'étanchéité neutre:
  - sur les coupes;
  - sur les trous de fixation;
- g. Sur les éléments composés, les résidus de matière d'étanchéité ne doivent être enlevés que des surfaces visibles, et ceci uniquement à l'aide d'un produit non-agressif (Reynafinish 60 art.n°. 086.9210.--).

### 1.2.2 Drainage, aération et découpes pour les accessoires

Etapes:

- a. Marquer les découpes.
- b. Poinçonnage, forage ou fraisage correct.
- c. Protection des surfaces traitées par:
  - ébavurage (si nécessaire);
  - enlèvement des poussières et des copeaux sur les scies et dans la chambre du profilé
  - dégraisse (Reynafinish art. n°. 086.9210.--);
  - application de Reynaprotector (art. n°. 086.9208.SY + 086.9225.--);

Lors du drainage / aération, il faut prêter attention aux points suivants:

Les eaux d'infiltration éventuelles doivent être évacuées de façon rapide et contrôlée vers l'extérieur et il faut maintenir la chambre de décompression à la pression atmosphérique.

- Pour chaque élément coulissant, des ouvertures de drainage sont prévues à une distance maximale de l'extrémité du profilé de base de 100 mm pour le profilé de dormant. La distance maximale entre 2 ouvertures de drainage est de 800 mm.  
Pour chaque surface vitrée il faut prévoir 2 trous de drainage !
- Les éléments coulissants, quel que soit leur type, doivent obligatoirement être drainés au niveau des traverses basses.
- La surface minimale de ces ouvertures est de 50 mm<sup>2</sup> par ouverture dans le dormant / l'ouvrant, soit sous forme d'une ouverture ronde avec un diamètre minimal de 8 mm, soit sous forme d'une ouverture ovale de 5 mm X 15 mm au minimum. Pour le dormant, la surface minimale est de 150 mm<sup>2</sup> par ouverture, soit sous forme de 3 ouvertures rondes avec un diamètre minimal de 8 mm, soit sous forme d'ouverture ovale de 8 mm X 34 mm au minimum, sauf description contraire dans les plans de montage.
- Les ouvertures de drainage qui sont visibles de l'extérieur de l'élément coulissant doivent recevoir des capuchons en matière synthétique, au niveau supérieur sans rabat (réf. 069.6831.XX), au niveau inférieur avec rabat (réf. 069.6830.XX).
- Chaque élément coulissant doit être prévue de trous d'aération. Sa fonction est de garantir l'égalisation de la pression autour du vitrage.

Remarque: Pour des drainages spécifiques, nous nous référons à la page 25.F. ...

### 1.2.3 Joints

Tous les joints sont en matière résistant aux intempéries et au vieillissement. Leur montage doit se faire soigneusement, puisque l'étanchéité de l'élément coulissant en dépend.

#### a. Application des joints.

Etapes:

1. Découpe correcte: la découpe du joint doit se faire avec des ciseaux spéciaux (art. n°. 090.0121.UN) et le joint peut être coupé à onglet ou droit en fonction du type de jonction entre les profilés. Une longueur supplémentaire (environ 10 mm par mètre) doit être prévue.
2. Application du joint: les joints sont appliqués dans les rainures des profils prévues à cet effet; la longueur supplémentaire est légèrement refoulée pour neutraliser la dilatation ou le rétrécissement.  
Les difficultés de mise en place peuvent être résolues à l'aide d'un aérosol silicone (art. n°. 086.9551.--).
3. Encollage (étanchement): selon le type de raccord de profilé (droit), le joint doit être encollé aux extrémités avec une colle à prise rapide (Reynaglué n° 084.9106.--). Cet encollage est nécessaire pour éviter que le joint glisse.

#### b. Application des brosses.

Etapes:

1. Découpe correcte: la découpe de la brosse doit se faire avec des ciseaux spéciaux (art. n° 090.0121.UN) et le joint peut être coupé à onglet ou droit en fonction du type de jonction entre les profilés.
2. Application de la brosse: les brosses sont appliqués dans les rainures des profils prévues à cet effet.
3. Encollage: En fonction du type de jonction entre les profils (droit), la brosse doit être encollée aux extrémités avec de la colle rapide (Reynaglué art. n°. 084.9106.--). Cet encollage est nécessaire pour éviter le glissement de la brosse.

#### c. Application d'une fermeture en bas et en haut de la chicane.

Afin d'obtenir une bonne étanchéité à l'eau et au vent, une fermeture supplémentaire doit être montée en bas et en haut de la chicane dans l'atelier:

- 2-rail / 3-rail porte coulissante (HFP 147 – HFP 179) : en bas et en haut art. n°. 062.8081.04 + encollage avec colle à prise rapide (Reynaglué n° 084.9106.--) avec 3x brosse (081.9135.SY)
- Afin de garantir une connexion étanche entre l'intérieur et l'extérieur, l'article doit être siliconées complètement (le dessous et les côtés) dans la barrette.
- L'installation de l'article en usine, servira comme garantie que les silicones seront sèche complètement. Si on applique (avec silicone) l'article quand même sur le chantier, l'article ne va pas rester sur place pendant qu'on finalise le reste de l'élément. L'installation des capots de finition aidera à tenir 062.8081.04 sur place.

- Si une partie du matériel doit être enlevé, par exemple quand il y a un recouvrement avec le bloc de fixation, ce n'est pas permis d'enlever complètement les 'ailes' de l'article afin de garantir l'étanchéité (au vent/eau) du système.

## II.2 RECOMMANDATIONS DE MONTAGE

### II.2.1 Montage dans le gros œuvre

Il est fortement déconseillé de placer Hi-Finity dans des milieux agressifs.

Le système Hi-Finity a été développé pour permettre un alignement parfait entre l'intérieur et l'extérieur du bâtiment. C'est la raison pour laquelle les profilés sont intégrés dans la construction du sol, murs et plafonds. La préparation des connections gros-œuvre est primordiale afin d'obtenir la qualité esthétique ciblée pour ce système. Ca va de même, que la mesure et la fabrication de l'ouverture dans le bâtiment doivent être réalisées avec une grande précision afin de réaliser les tolérances requises, surtout dans la profondeur du système (alignement des sections du cadre).

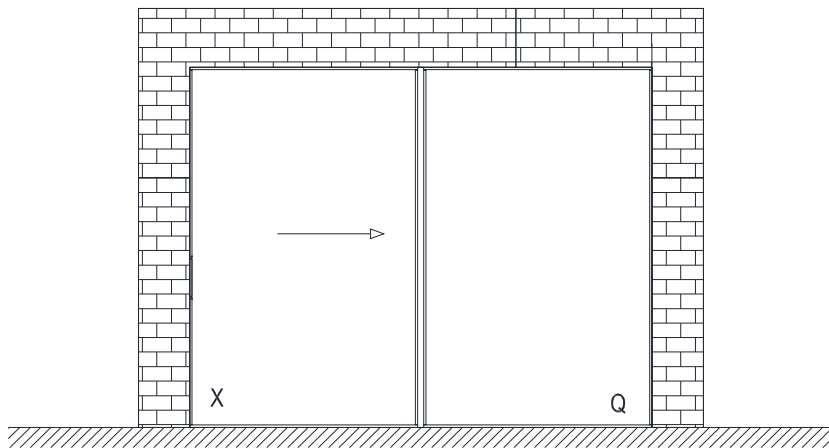

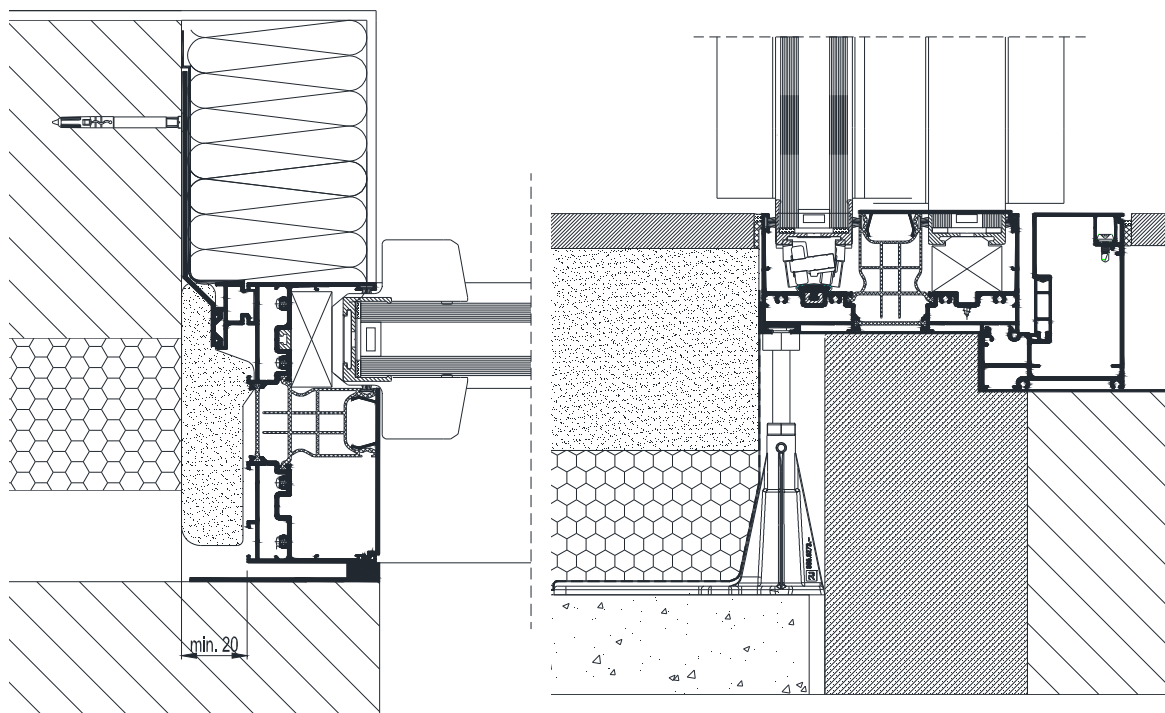

La connexion entre le cadre du système avec la structure (terrasse) peut se réaliser de deux façons:

- Dans le cas d'une terrasse non-perméable, l'installation d'une gouttière est nécessaire pour évacuer l'eau présente devant le système. Cette gouttière est drainé ou en-dessous, ou par les cotées de la terrasse.
- Dans le cas d'une terrasse ou structure perméable, la gouttière n'est plus nécessaire, et la terrasse continuera jusqu'au profilé du cadre.

A la côté supérieure le système HFP doit aussi être intégrer dans la façade. La façade est supportée par une structure qui servira d'avantage aussi le système d'antiefraction.

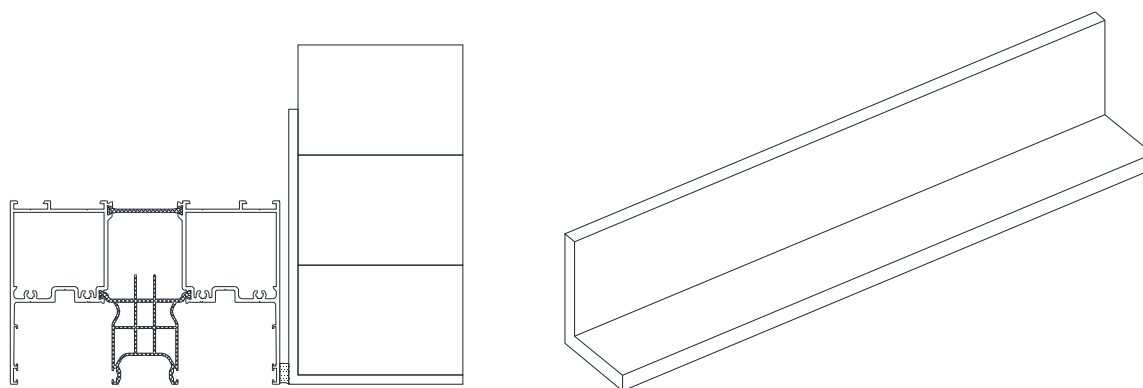

Le certificat RC2 antieffraction est lié au verre P4A (EN 356) et au système HFP intégré. Le système est développé comme une partie intégrée du bâtiment et a aussi été testé de la même façon. Si le système n'est pas construit en accord avec les prescriptions, le certificat RC2 n'est pas applicable.

La fixation au gros œuvre se fait soit directement à travers les profils avec par exemple des vis et des chevilles, soit à l'aide d'ancrages de fixation.

- Les fixations ne peuvent pas être appliquées à une distance inférieure à 40 mm du mur du gros œuvre..
- L'ancrage ne peut surtout pas influencer la force portante des éléments de construction contigus.
- Tous les ancrages, pour autant qu'ils ne soient pas en aluminium ou en acier inoxydable, doivent être efficacement protégés contre la corrosion et ne peuvent pas corroder l'aluminium.
- Lors de la pose des éléments coulissants, on prévoit des fixations en suffisance:

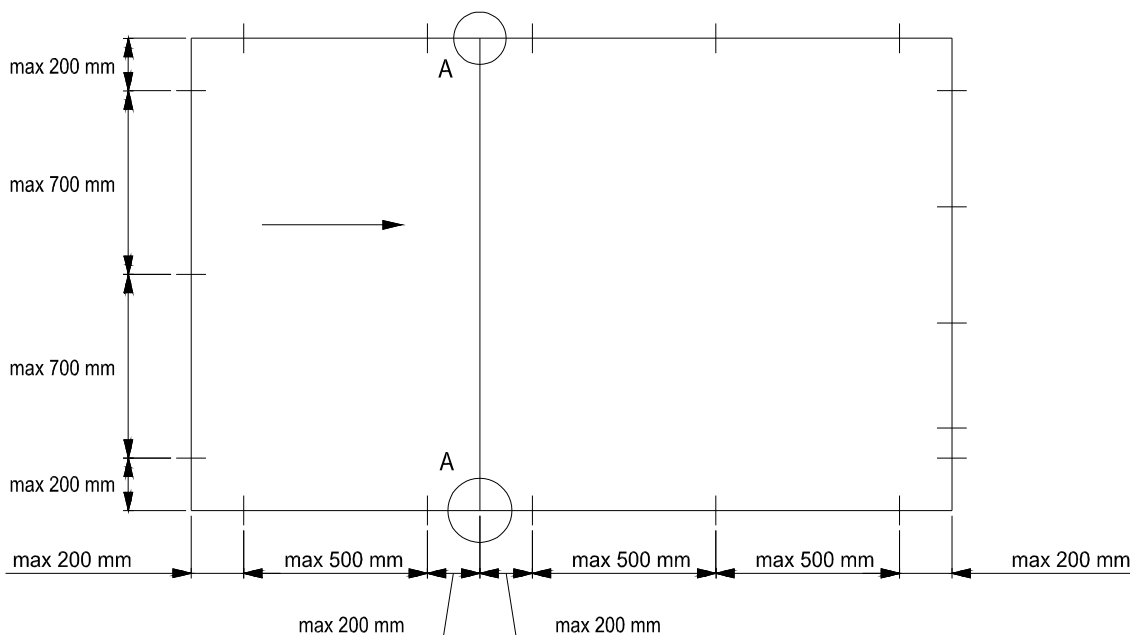

De tous les côtés il doit y avoir au moins 2 fixations avec une distance maximale jusqu'à l'angle de 200 mm.

- La distance entre les fixations est de 700 mm au maximum (500 mm dans le cas d'une traverse basse).
- Aux endroits où des profilés intermédiaires se trouvent entre les traverses haute et basse, l'ancrage doit être appliqué à une distance maximale de 200 mm du centre des profilés intermédiaires (A).
- La traverse basse doit continuellement être soutenue pour éviter toute flexion.

Remarque: Les ancrages doivent être appliqués d'une telle façon qu'ils peuvent neutraliser des dilatations / rétrécissements éventuels de l'élément coulissant.

Si des vis et des chevilles sont utilisées à travers les profils, les Chambers dans le dormant inférieur ne peuvent pas être percées afin d'éviter de l'infiltration d'eau à la hauteur de cette fixation.

## II.2.2 Montage des accessoires

La lame de verre collée contient une ouverture des deux côtés afin de permettre l'installation des accessoires. Après l'installation des accessoires et les profilés, ces ouvertures ne seront plus visibles.

De l'information supplémentaire sur l'installation et le réglage des accessoires sont intégré dans le catalogue, montré sur le site web article ou montré dans la documentation fournit avec l'emballage de l'article en question.

Le choix des points de fixation, du nombre de points de fixation, du poids max. D'ouvrant, des dimensions max. d'ouvrant, du profile ouvrant appliqué, etc. doit se faire suivant les introductions du fournisseur des systèmes et du fabricant des accessoires.

Les parties coulissantes et mobiles doivent être pourvues de graisse neutre.

Lors du montage, il faut contrôler si les accessoires (y compris les composants électroniques) peuvent être actionnés de façon souple et sans bloquer.

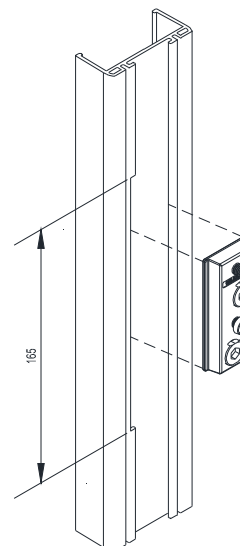

### II.3 VITRAGE

La lame de verre est collé avec un profilé composite par un fournisseur certifié Reynaers, et commandé au sein de Reynaers à la main d'un formulaire de commande standardisé. La lame de verre collée à une ouverture des deux cotés pour l'intégration des accessoires.

Le profilé composite est interrompu quand une poignée sera intégré (les positions peuvent être indiqués sur le bon de commande pour le verre Hi-Finity). Après mise en œuvre de la poignée, l'ouverture se couvre avec un capot de finition. Les capots de finitions sont collés sur la lame de verre avec une matière d'étanchéité de Dow Corning (eg. DC895) ou un produit équivalent qui est compatible avec la colle utilisé pour le verre.

On peut choisir entre différents types de verre selon la configuration à construire. Afin de faciliter la communication, chaque type a reçu un identifiant avec une lettre. Toutes les vues sont des vues de l'extérieur du bâtiment.

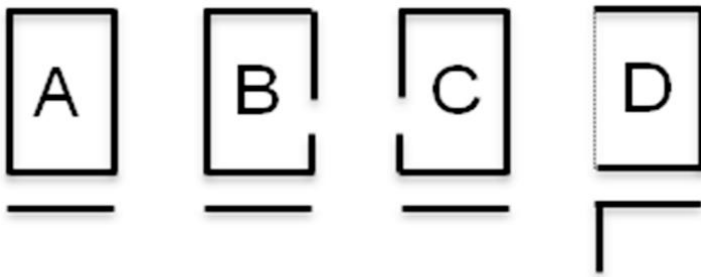

- A: du verre sans poignée
- B: du verre avec la poignée à la droite
- C: du verre avec la poignée à la gauche
- D : du verre pour un angle fixe

La relation entre les dimensions du produit fini, et les dimensions du verre:

Les dimensions de verre obtenu à travers le bon de commande par le fichier Reynapro, sont les dimensions avant le collage structurelle. Le catalogue montre les mêmes dimensions. Le verre assemblé avec le profilé composite (collé de manière structurelle) a des dimensions plus grandes que le verre tout seul. Afin de faciliter la vérification d'une commande pendant la livraison, vous pouvez suivre les directions suivantes:

En cas de type A, B ou C:

- Pour le HFP 147 : les dimensions du verre + 19 mm (de même pour la hauteur que la largeur) +/- 1 mm tolérance

En cas de type D (un collage structurelle verre-verre)

- La commande nécessite un dessin précis et détaillé
- Pour le HFP 147 : les dimensions du verre + 19 mm (de même pour la hauteur que la largeur) +/- 1 mm tolérance
- Le fournisseur du verre vient coller les lames de verre sur le chantier

Dans le cas que le verre est hors tolérances, on vous prie de prendre contact avec votre liaison Reynaers.



## III. SEQUENCE D'ASSEMBLAGE HFP 147

1 KEUZE CONFIGURATIE  
 CHOIX DE CONFIGURATION  
 CONFIGURATION SELECT  
 WAHL KONFIGURATION

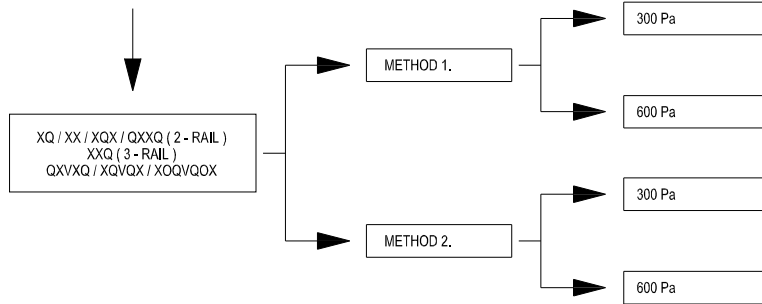

2 ZAGEN  
 SCIER  
 SAWING  
 SAEGEN

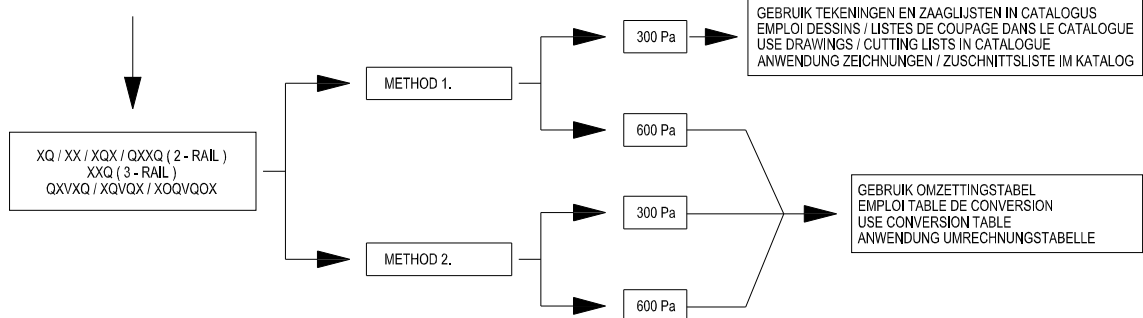

3 FREZEN  
 FRAISE  
 MILLING  
 FRAESE

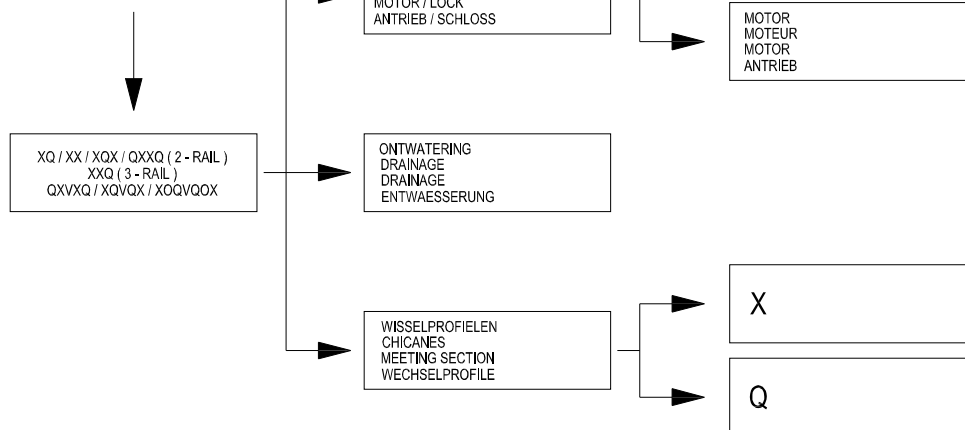



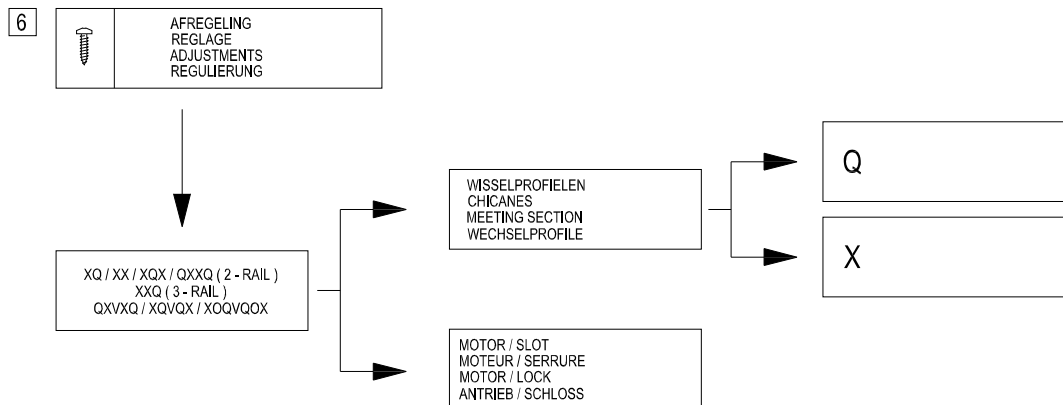
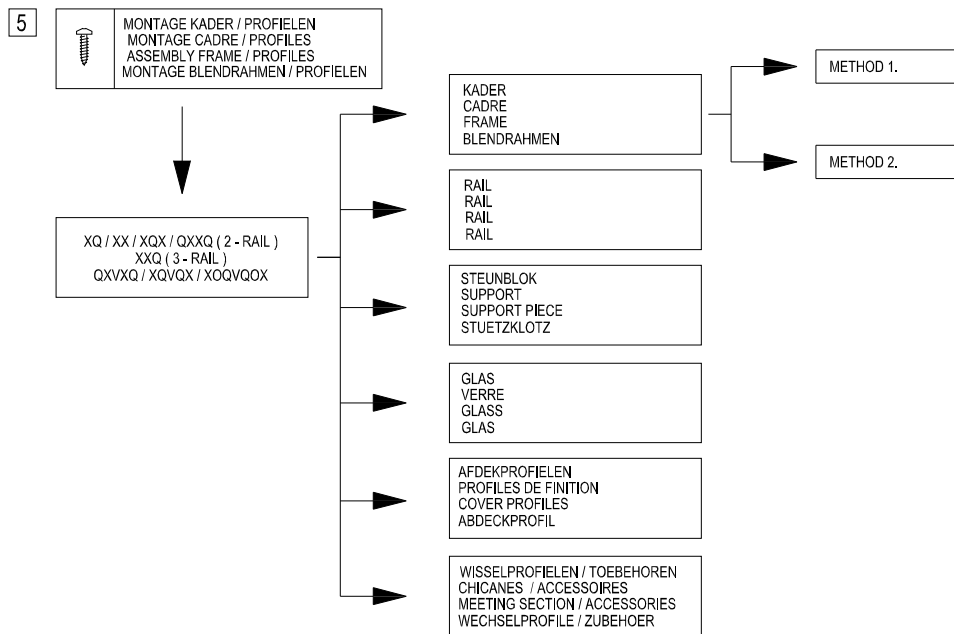
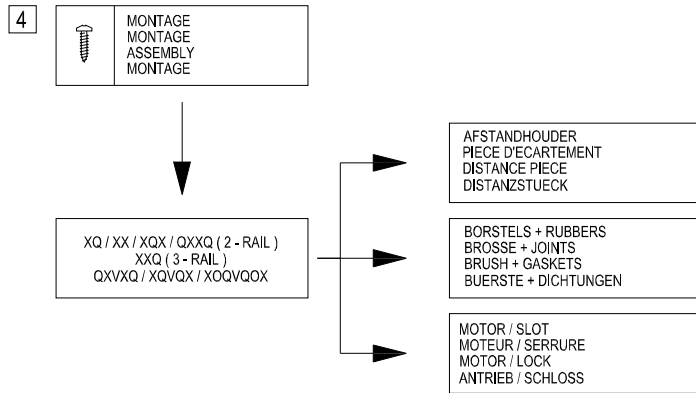



# PROCESSING DATA

## I. GENERAL

See catalogue "1.General information"(089.C01E.00 edition 11/2004)

## II. PROCESSING DATA HFP 147

### II.1 FABRICATING PRESCRIPTIONS

In order to guarantee a perfect end product, the following guidelines should be adhered to during the production process.

#### II.1.1 Metal-removing operations

Metal-removing operations are understood to mean all mechanical operations such as sawing, milling, drilling, punching and cutting. For painted profiles it is essential that the paint coatings do not come off on the edges during these operations.

Therefore it is very important for the quality of the connections that:

- The metal-removing tools are appropriate and sufficiently sharp.
- The machines are well adjusted (e.g. number of revolutions).
- The tools are regularly checked.
- The metal-removing tools are greased sufficiently and correctly:
  - Reynalube cutting grease block (art. no. 086.9191.UN) for saw blades.
  - cutting spray (art. no. 086.9175.--) for punch tools.
  - or the cooling agents and lubricants prescribed by the machine suppliers.
- The appropriate clamp blocks are used. (see assembly drawing "clamp blocks saw")
- The cutting table is free of swarf and dust.
- Possible cooling is done by means of chemically neutral products which do not attack the surface treatment.

#### II.1.2 Assembly

We make the following subdivisions:

1. Corner connections;
2. Drainage, aeration and recesses for the accessories;
3. Gaskets.

##### 1.2.1 Corner connections

Steps:

- a. Choose corner connection method (depending on available machines):
  - METHOD 1: Millings for corner connections are 68mm deep (possible with most milling machines T-junction, but extra corner piece 062.9315.04 necessary to make connection between low and high frame profiles).
  - METHOD 2: Milling for corner connection is 100mm deep when connecting to a high frame profile (possible with double saw, maybe not with milling machine T-junction, no corner piece necessary)
- b. Correct sawing of the outer frame profile.
- c. Applying holes outer frame profile (□ 10mm; □ 5mm).
- d. Double-saw the outer frame profile (height depends on the chosen outer frame profile, and the chosen connection type).
- e. Protection of the saw cuts and treated surfaces by:
  - Deburring (if necessary);
  - Removing dust and saw-dust on the saw cut and in the profile chamber;
  - Degreasing (Reynafinish 60 art. no 086.9210.--);
  - Applying Reynaprotector (art. no. 086.9208.SY + 086.9225.--).
- f. Sealing of the outer frame profile by applying a neutral sealing agent:
  - on the saw cuts;
  - on the fixing holes;
- g. The sealing agent residue on the visible sides of the completed elements has to be removed by means of a non-aggressive product (Reynafinish 60 art.no. 086.9210.--).

### 1.2.2 Drainage and recesses for the accessories

#### Steps:

- a. Marking of recesses.
- b. Correct punching, drilling or milling.
- c. Protection of the treated surfaces by:
  - Deburring (if necessary);
  - Removing dust and saw-dust on the saw cuts and in the profile chamber.
  - Degreasing (Reynafinish 60 art. no. 086.9210.--).
  - Applying Reynaprotector (art. no. 086.9208.SY + 086.9225.--).

Special attention should be paid to the following regarding drainage / aeration:

Possible infiltrating water must be drained smoothly under control and one must be sure that the profile's chambers remain at the atmospheric pressure.

- For all sliding elements, drainage holes should be provided a maximum of 100 mm from the end of the floor profile of the outer frame profile. The maximum distance between 2 drainage holes is 800 mm. Each glazed surface should be provided with min. 2 drainage holes!
- All types of sliding elements should be provided with a drainage system in the sills;
- The minimum surface of these openings is 50 mm<sup>2</sup> per opening in the frame/vent, either a round opening of minimum 8 mm diameter, or elongated openings of minimum 5 mm by 15 mm. For the outer frame the minimum surface is 150 mm<sup>2</sup> per opening, either 3 round openings of minimum 8 mm diameter, or an elongated opening of minimum 8 mm by 34 mm, unless shown otherwise in the assembly drawings.
- Drainage holes which are visible on the outside of the sliding element are covered with drainage covers in synthetic material, at the top without flaps (art. no. 069.6831.XX), and at the bottom with flaps (art. no. 069.6830.XX).
- All sliding elements are provided with ventilation holes. Its function is to guarantee the pressure equalization around the glazing..

Remark: For specific drainage we refer to pages 25.F. ...

### 1.2.3 Gaskets

All gaskets are made of a material resistant to weathering and ageing. They should be carefully applied since the tight sealing of the sliding elements depends on their correct application.

#### a. Applying the gaskets.

##### Steps:

1. Correct cutting: the glazing gasket should be cut with special gasket shears (art. no. 090.0121.UN) and can be cut straight or mitred according to the kind of profile connection. Extra overhanging (about 10 mm per meter) is required.
2. Application of the gasket: the gaskets are applied in the appropriate grooves within the profiles. They should be cut slightly longer than is necessary to compensate for any shrinkage that may occur. Difficulties in applying the gasket can be solved by the use of silicone spray (art. no. 086.9551.--).
3. Gluing (sealing): Depending on the type of profile connection (straight), the ends of the gasket should be glued with superglue Reynaglue art. no. 084.9106.--). This gluing is necessary to prevent the gasket sliding out.

#### b. Applying the brushes.

##### Steps:

1. Correct cutting: the brush should be cut with special gasket shears (art. no. 090.0121.UN) and can be cut straight or mitred according the kind of profile connection.
2. Application of the brush: the brushes are applied in the appropriate grooves within the profiles.
3. Gluing: In function of the type of profile connection (straight), the brush should be glued at the ends with contact glue (Reynaglue art. no. 084.9106.--). This gluing is necessary to avoid the slipping away of the brush.

#### c. Applying a closer at the bottom and the top of the meeting section.

To obtain a good water tightness, an extra closer should be fitted in the workshop at the bottom and top of the meeting section:

- 2-rail / 3-rail sliding door (HFP 147 – HFP 179): At bottom and top art. no. 062.8081.04 + glued with superglue (Reynaglue art. nr. 084.9106.--) with 3x brushes (081.9135.SY)
- The article acts as a barrier between inside and outside, so it has to be siliconized completely (bottom and sides) into the insulation profile.
- Installation of this part in the work shop will ensure the silicone to dry completely. Installation on site can cause this part to slide when fitting and adjusting the system. Installing cover caps will help to hold 062.8081.04 in place as well.
- If material needs to be removed, e.g. when in overlap with the fixation block, do not remove the "wing" completely, always leave a portion of the wing intact to insure wind-/water tightness.

## II.2 FITTING

### II.2.1 Fitting in the structural work

We advise most strongly against installing Hi-Finity in aggressive environments.

Hi-Finity has been developed for a seamless connection (alignement parfait) between the inside of the building and the outside. For this reason the frame profiles are built into the floor, ceiling and walls. Preparation of the building connections is extremely important to attain the aesthetic quality this system was meant to achieve. It also means the constructor has to be very precise while measuring and fabricating the opening for the system, to achieve minimal tolerances especially in depth (to fit the sections of the frame).

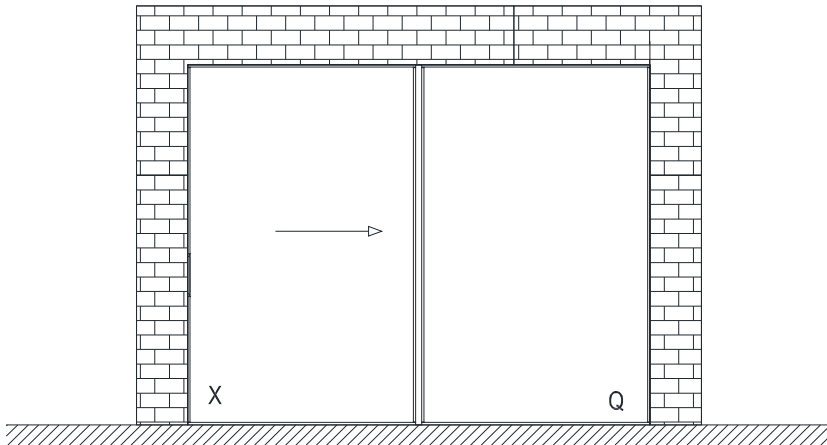

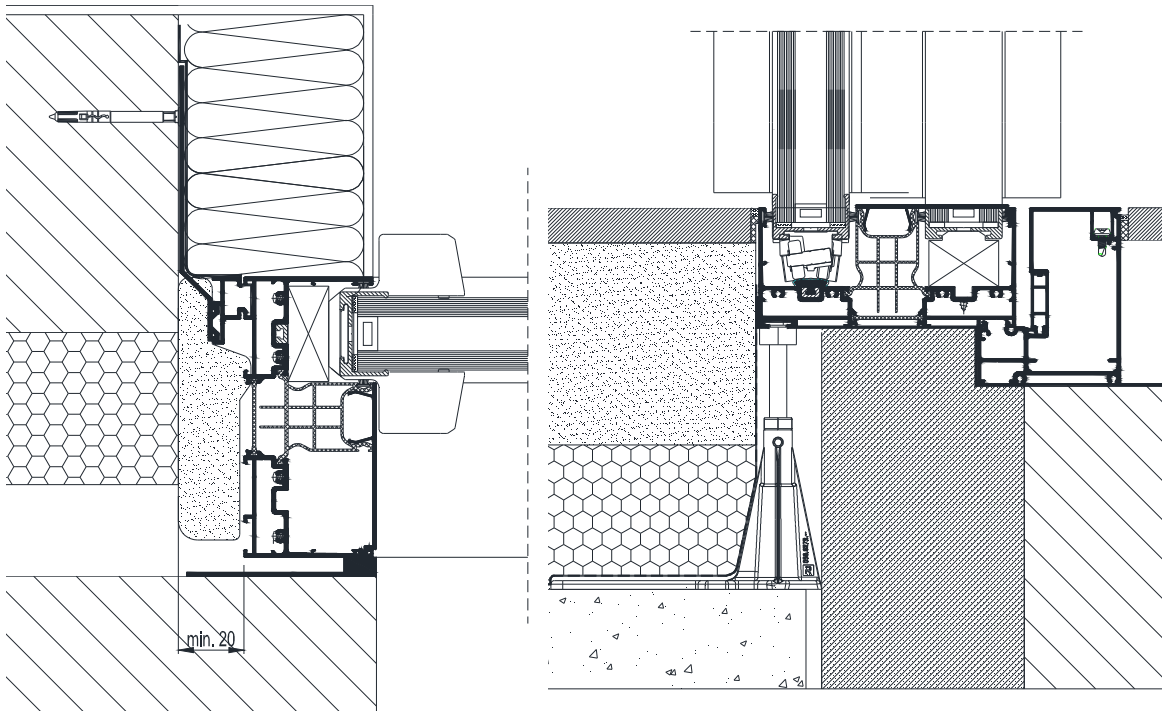

The connection of a structure (terrace) to the frame can be done in 2 ways:

- The terrace is an impermeable structure: no drainage through the surface. A gutter profile is needed to evacuate the water in front of the system. This gutter can then be drained underneath or towards the sides of the terrace.
- The terrace is a permeable structure: water can be drained through the surface. Gutter profile is not necessary and the terrace can be extended up to the frame profile.

The top of the HFP system also needs to be built into the facade. The facade is supported by a structure, which also protects the system from burglary.

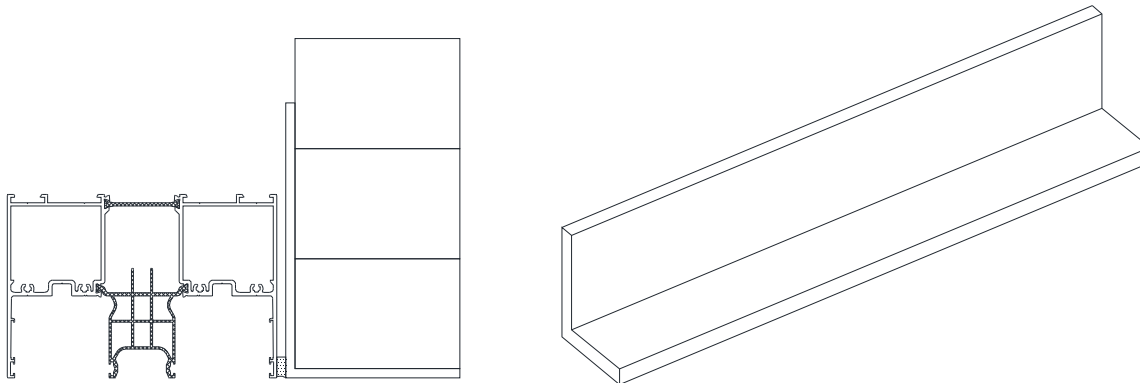

The RC2 certificate has been given for P4A glass (EN 356) and a built-in system. The system is developed as an integral part of the building, and is tested as such. If the element is not installed according to these guidelines, the RC2 certificate is not applicable.

The fixing to the structural work is done either directly through the profiles by means of for instance screws and plugs, or by means of fixing lugs.

- The fixings may not be applied less than 40 mm of the wall of the structural work.
- The anchoring may in no way influence the bearing power of the adjacent building parts.
- All anchoring, as far as they are not made of Aluminium or stainless steel, should be adequately corrosion-protected and may not attack the Aluminium themselves.
- When fitting the sliding elements, sufficient fixings are required:

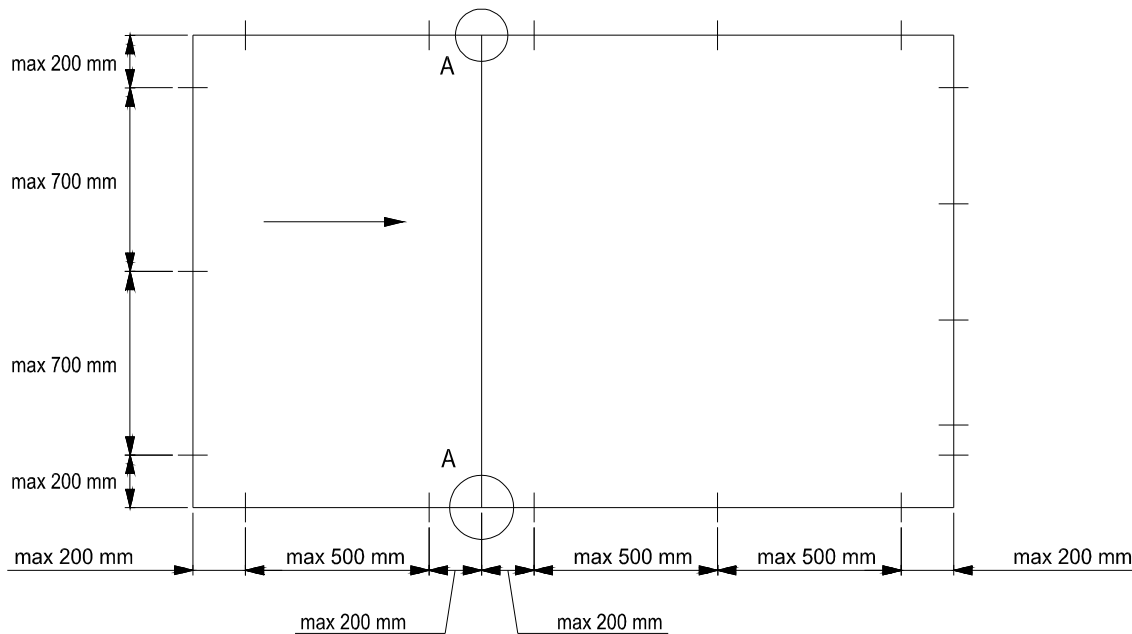

- At least two fixings should be applied on all sides; the maximum distance to the corner is at least 200 mm.
- The distance between the fixings is maximum 700 mm (500 mm in the case of the bottom profile).
  - Where the meeting sections are between the top profile and bottom profile, the fixing must be applied maximum 200 mm from the centre of the meeting section (A).
  - The lower profile must be supported at all times, to prevent sagging.

Remark: The anchoring should be applied in such a way that possible expansion / shrinkage of the sliding element is not obstructed.

When screws and plugs are used directly through the profiles, the chambers in the bottom outer frame may not be pierced to avoid water infiltration at the height of this fixing.

## II.2.2 Fitting of the accessories

The glued glass has an opening on each side for fitting accessories, after installation of all articles and profiles, these gaps will be invisible.

More information on the installation and adjustability of the accessories can be found in the catalogue, on the article website or in the documentation inside the packaging of the particular article.

The choice of the fixing points, number of locking points, max. weight of the sliding panel, max. sizes of the sliding panel, panel profile used etc. depends on the instructions of the system supplier and the accessory producer. Sliding and moving parts should be provided with neutral grease.

When fitting, please check whether all accessories (including electronic components) can be operated easily and without getting stuck.

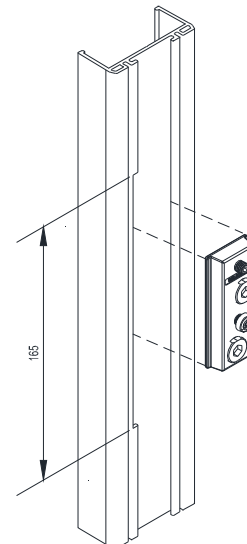

### II.3 GLAZING

The glass is glued with the composite profiles by a Reynaers approved glass supplier, ordered through Reynaers with a standardized order form. The glued glass has an opening on each side for fitting accessories.

Wherever a handle needs to be fitted (locations can be indicated on the order form for the Hi-Finity glass), the composite profile will be interrupted. After fitting the handle, the opening can be closed off with a cover cap. The cover caps must be fitted to the glued glass panel using a sealant made by Dow Corning (e.g. DC895) or an equivalent product that is compatible with glass adhesive.

There are a few different types of glass, depending on the type of configuration you choose to build. We have given each type a different letter for easy communication (all views are from the outside of the building):

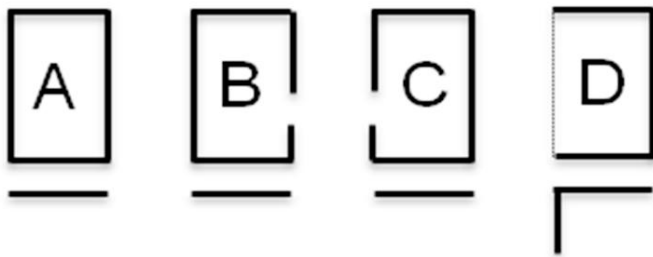

- A: glass without handle
- B: glass with handle on the right
- C: glass with handle on the left
- D: glass for fixed corners (both sides)

Dimensions of the glass vs. dimensions of the finished product:

The order form created from your Reynapro file, will indicate the glass dimensions before the process of structural glazing. The dimensions in the (online) catalogue also indicate the glass dimension before structural glazing.

The finished product is the glass with a structurally glued (composite) frame glued to it, which has other dimensions than the glass by itself. In order to check your order, you can follow these guidelines:

In case of type A, B or C:

- For HFP 147: glass dimension + 19mm (both width and height) +/-1mm tolerance.

In case of type D (structural connection):

- A detailed drawing of the configuration is needed for the order.
- For HFP 147: glass dimension + 19mm (both width and height) +/-1mm tolerance
- These glass panels are glued on site by the glass supplier.

If the glass is not within tolerances, you should contact your Reynaers connection.





## III. ASSEMBLY SEQUENCE HFP 147

1 KEUZE CONFIGURATIE  
 CHOIX DE CONFIGURATION  
 CONFIGURATION SELECT  
 WAHL KONFIGURATION

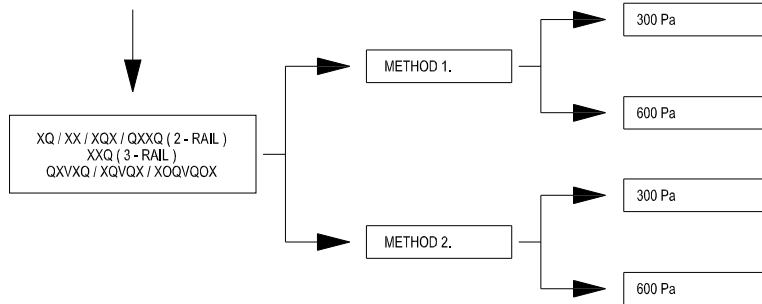

2 ZAGEN  
 SCIER  
 SAWING  
 SÄGEN

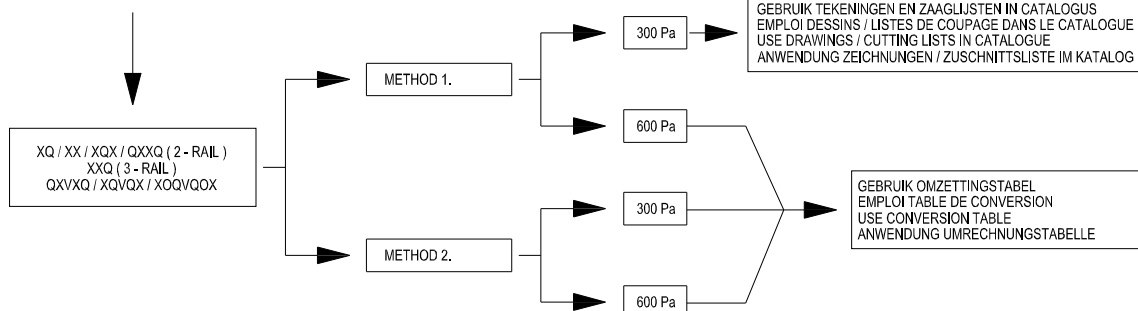

3 FREZEN  
 FRAISE  
 MILLING  
 FRAESE

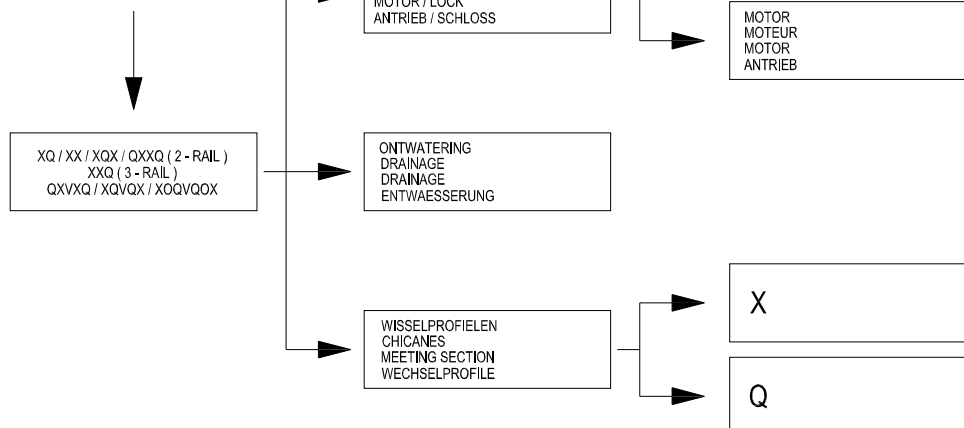

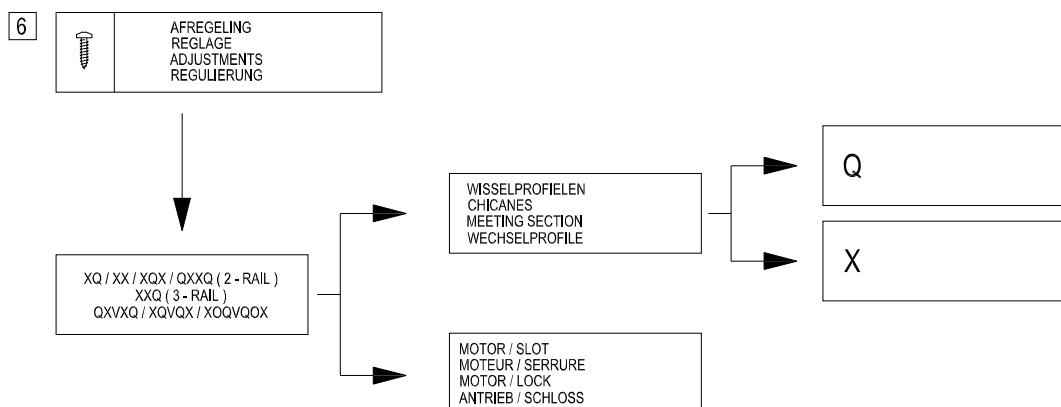
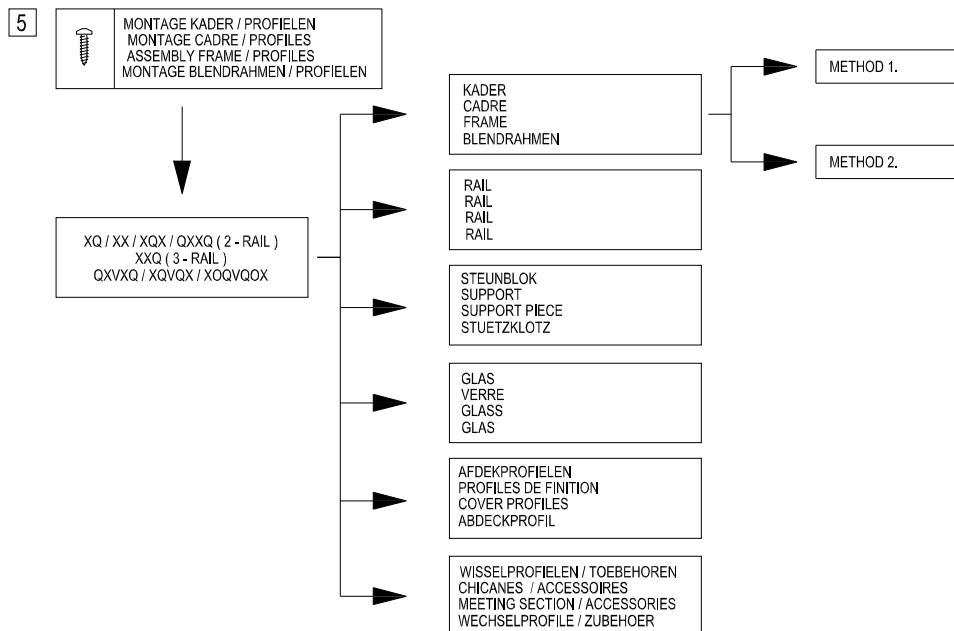
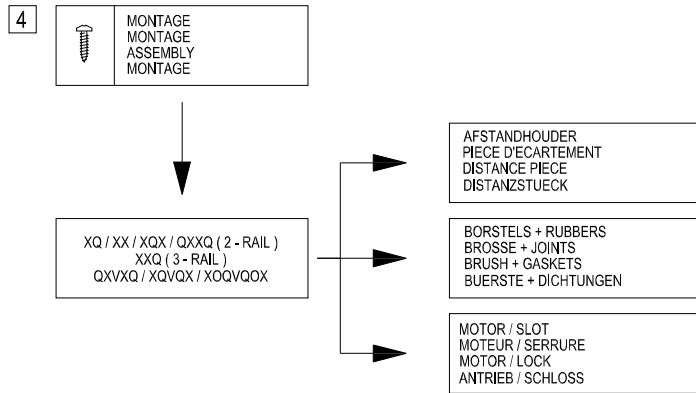



# VERARBEITUNGSVORSCHRIFTEN

## I. ALLGEMEIN

Siehe Katalog "1. Allgemeine information (089.C01E.00 Ausgabe 11/2004)

## II. VERARBEITUNGSVORSCHRIFTEN HFP 147

### II.1 VERARBEITUNG

Um ein qualitativ hochwertiges Endprodukt zu erstellen, sollen bei der Verarbeitung folgende Punkte berücksichtigt werden:

#### II.1.1 Spanende Bearbeitungen

Mit spanenden Bearbeitungen sind alle mechanischen Bearbeitungen, wie Sägen, Fräsen, Bohren, Stanzen gemeint.

Bei allen mechanischen Bearbeitungen ist auf den Einsatz geeigneter Sägeblätter, Fräser und Bohrer zu achten, damit die Oberfläche nicht durch Grate oder abplatzende Beschichtung beschädigt wird.

Zur Profilbearbeitung geben wir folgende Hinweise:

- Die spanabhebenden Werkzeuge müssen für den Werkstoff geeignet und ausreichend scharf sein.
- Die Maschinendrehzahl muss auf den Werkstoff Aluminium abgestimmt sein.
- Die Profilauflagen müssen sauber und spanfrei sein.
- Zur Verlängerung der Werkzeugstandzeiten können geeignete Gleitmittel verwendet werden, wie:

Fettstift Reynalube (Art. Nr. 086.9191.UN);

Reynaers-Schneidmittel (Art. Nr. 086.9175.--);

oder die von den Maschinenlieferanten vorgeschriebenen Kühl- und Schneidmittel verwendet werden.

- Die geeignete Spanbacken sollen angewandt werden (Siehe Montagezeichnung „Spanbacken“)
- Der Auflage- und Ablauftisch soll frei von Spänen und Verunreinigung sein;
- Diese Kühl- und Schneidmittel müssen chemisch neutrale Produkte sein, die die Oberfläche nicht angreifen.

#### II.1.2 Profilverbindungen und deren Verarbeitung

In den Reynaers-Katalogen wird nach 4 Verarbeitungsschritten unterschieden:

1. Eckverbindungen;
2. Entwässerung und Vorbereitung für den Beschlageinbau;
3. Dichtungen.

#### 1.2.1 Eckverbindungen

Verfahrensweise:

- a. Auswahl Methode Ecke-Verbindung (Abhängig den verfügbare Maschines):
  - METHODE 1: die Ausfräsungen im Rahmprofil sind 68 mm tief (möglich mit den meisten T-Fräsen, aber zusätzliches Zubehörteil 062.9315.04 notwendig um eine Verbindung zwischen den niedrigen und hohen Rahmprofile zu machen.
  - METHODE 2: die Ausfräsungen im Rahmprofil sind 100 mm tief bei einer Verbindung zwischen den hohen und niedrigen Rahmen (möglich mit Auslinksäge, aber vielleicht nicht mit einer T-Fräse, kein zusätzliches Zubehörteil nötig.
- b. Außenrahmen korrekt zuschneiden.
- c. Löcher in Außenrahmen anbringen (□ 10mm; □ 5mm).
- d. Ecken des Außenrahmens ausfräsen (Höhe in Abhängigkeit vom gewählten Außenrahmen und Verbindung den Ecke)
- e. Schutz der Schnittkanten und bearbeiteten Oberflächen durch:
  - Entgräten (falls erforderlich);
  - Schnittfläche und Profilkammern von Staub und Sägeresten säubern;
  - Entfetten der Profile (Reynafinish Art. Nr. 086.9210.--);
  - Korrosionsschutzprodukt (Reynaprotector Art. Nr. 086.9208.SY + 086.9225.--) aufbringen;
- f. Abdichtung: des Außenrahmens durch den Einsatz eines neutralen elastischen Dichtungsmittels wasserdicht ausführen:
  - an den Sägeschnitten
  - an den Befestigungslöchern
- g. Nach dem Zusammenfügen müssen überschüssige Dichtungsmittelreste entfernt werden (Reynafinish Art. Nr. 086.9210.--).

## 1.2.2 Entwässerung und Bearbeitung für den Beschlageinbau

Verfahrensweise:

- a. Die Aussparungen markieren.
- b. Korrekt stanzen, bohren oder fräsen.
- c. Schutz der Schnittkanten:
  - Entgräten (falls erforderlich);
  - Schnittfläche und Profilkammern von Staub und Sägeresten säubern;
  - Entfetten der Profile (Reynafinish Art. Nr. 086.9210.--);
  - Korrosionsschutzprodukt (Reynaprotector Art. Nr. 086.9208.SY + 086.9225.--) aufbringen;

Insbesondere ist auf folgendes zu achten:

Eventuell eingedrungenes Wasser muss problemlos und kontrolliert abgeleitet werden können

Es sind entsprechende Dampfdruckausgleichsbohrungen vorzunehmen.

- Bei jedem Schiebeelement sind Entwässerungsbohrungen in einem Abstand von maximal 100 mm vom Ende des Bodenprofils des Außenrahmens vorzunehmen. Der Abstand zwischen 2 Entwässerungsöffnungen betragen max. 800 mm.  
Für jede Glasoberfläche sollen mindestens 2 Entwässerungslöcher vorgesehen werden.
- Alle Schiebeelemente müssen im Solbankbereich mit entsprechenden Ausnehmungen versehen werden.
- Die Mindestoberfläche der Entwässerungsöffnung beträgt 50 mm<sup>2</sup> pro Öffnung im Rahmen/Flügel, wobei eine Bohrung von mind. 8 mm Durchmesser oder zwei Schlitze von 5 x 15 mm vorzusehen ist. Für den Blendrahmen beträgt die Mindestoberfläche pro Öffnung 150 mm<sup>2</sup>, wobei 3 Bohrungen von mind. 8 mm Durchmesser oder einen Schlitz von 8 x 34 mm vorzusehen ist, soweit in den Montagezeichnungen nicht etwas anderes beschrieben ist.  
Alle sichtbaren Entwässerungsöffnungen müssen mit systemabhängigen Kunststoff-Abdeckkappen versehen werden, auf der oberen Ebene ohne Klappen (Artikel 069.6831.XX), auf der unteren Ebene mit Klappen (Artikel 069.6830.XX)
- Bei jedem Schiebeelement sind grundsätzlich zwei Entlüftungsbohrungen vorzunehmen damit die Druckegaliserung rundum der Verglasung zu gewährleisten.

Bemerkung: Spezifische Entwässerungsbohrungen sind gemäß der Seite 23.f. ... vorzunehmen.

## 1.2.3 Dichtungen

Alle angebotenen Dichtungen bestehen aus einem Material mit einer hohen Alterungs- und Witterungsbeständigkeit. Die Verarbeitung der Dichtungen hat sorgfältig und entsprechend den folgenden Hinweisen zu erfolgen:

### a. Einbringen der Verglasungsdichtungen/Dichtungen.

Verfahrensweise:

1. Die Verglasungsdichtung wird je nach Erfordernis mit einer speziellen Schere (Art. Nr. 090.0121.UN) gerade oder auf Gehrung zugeschnitten. Je lfdm. Dichtung ist eine Überlänge von 10 mm hinzuzurechnen.
2. Das Einbringen der Dichtung erfolgt in die vorgesehenen Dichtungsaufnahmen. Beim Einbringen der Dichtungen wird der überlange Zuschnitt durch Stauchen der Dichtungsprofile ausgeglichen. Durch die Anwendung des Silikonssprays (Art. Nr. 086.9551.--) wird das Einbringen der Dichtungen erleichtert.
3. Verkleben (Abdichten): Je nach Art der Profilverbindung (gerade) muss die Dichtung an den Enden mit Sekundenkleber verklebt werden (Reynaglu Art.-Nr. 084.9106.--). Diese Verklebung ist notwendig, um das Herausrutschen der Dichtung zu verhindern.

### b. Bürstendichtungen.

Verfahrensweise:

1. Die Bürstendichtung wird je nach Erfordernis mit einer speziellen Schere (Art. Nr. 090.0121.UN) gerade oder auf Gehrung zugeschnitten.
2. Das Einbringen der Dichtung erfolgt in die vorgesehenen Dichtungsaufnahmen.
3. Je nach der Art Profilverbindung (gerade) wird die Bürstendichtung an den Enden mit Sekundenkleber (Reynaglu Art. Nr. 084.9106.--) verklebt. Dank dieser Verklebung wird das Ausrutschen der Bürstendichtung vermieden.

### c. Abdichtung unten und oben auf dem Wechselprofil.

Für eine gute Wasser- und Winddichtheit soll unten und oben auf dem Wechselprofil in der Werkstatt eine zusätzliche Abdichtung montiert werden:

- 2-rail / 3-rail Schiebetür (HFP 147 – HFP 179): unten und oben Art. Nr. 062.8081.04 + verklebt mit Sekundenkleber (Reynaglu Art.-Nr. 084.9106.--) mit 3x Bürste (081.9135.SY)
- Der Artikel wirkt als Sperre zwischen innen und außen, deshalb muss er vollständig (unten und seitlich) in das Isolierungsprofil silikonisiert sein.
- Die Installation dieses Teils in der Werkstatt gewährleistet, dass das Silikon vollständig trocknet. Die Installation vor Ort kann dazu führen, dass dieses Teil bei Montage und Einstellung des Systems verrutscht. Auch der Einbau von Abdeckkappen hilft, 062.8081.04 in Position zu halten.

- Wenn Material entfernt werden muss, z. B. wenn es mit dem Befestigungsblock überlappt, den „Flügel“ nicht vollständig entfernen, sondern immer einen Teil des Flügels intakt lassen, um Wind-/Wasserdichtheit zu gewährleisten.

## II.2 MONTAGE

### II.2.1 Befestigung am Baukörper

Vom Einsatz von Hi-Finity in aggressiven Umgebungen wird dringend abgeraten.

Hi-Finity wurde für eine nahtlose Verbindung zwischen dem Inneren des Gebäudes und der Außenseite entwickelt. Aus diesem Grund werden die Rahmenprofile in Boden, Decke und Wände eingebaut. Die Vorbereitung der Gebäudeanschlüsse ist äußerst wichtig, um die beabsichtigte ästhetische Qualität dieses Systems zu erreichen. Es bedeutet auch, dass der Konstrukteur beim Messen und Herstellen der Öffnung für das System sehr genau arbeiten muss, um minimale Toleranzen besonders in der Tiefe zu erreichen (passend zu den Sektionen des Rahmens).

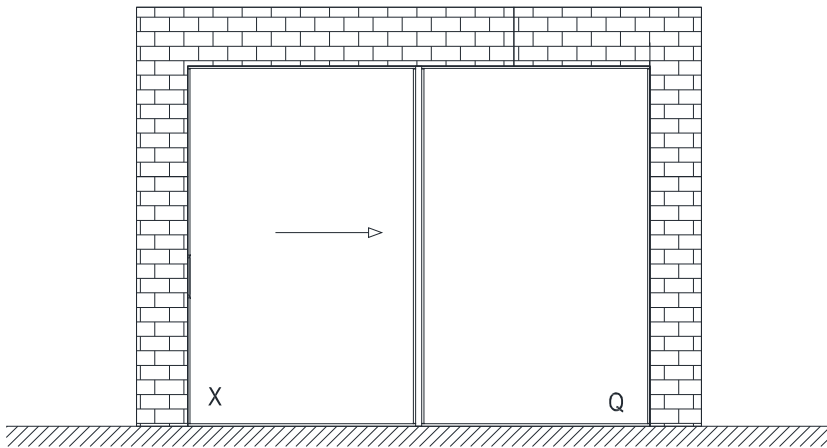

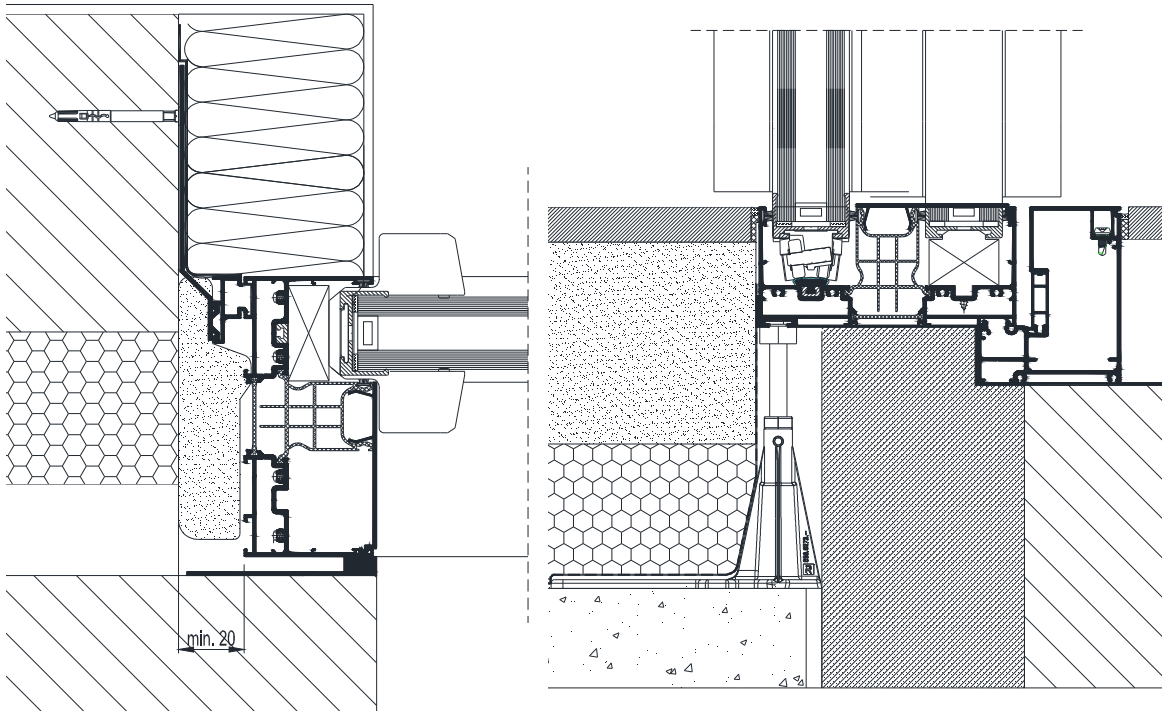

Die Verbindung einer Konstruktion (Terrasse) mit dem Rahmen kann auf 2 Weisen erfolgen:

- Die Terrasse ist eine undurchlässige Konstruktion: kein Abfließen durch die Oberfläche. Ein Rinnenprofil wird zum Ableiten des Wassers an der Vorderseite des Systems benötigt. Diese Rinne kann dann unten oder zur Seite der Terrasse entwässert werden.
- Die Terrasse ist eine durchlässige Konstruktion: Wasser kann durch die Oberfläche abfließen. Ein Rinnenprofil ist nicht notwendig, und die Terrasse kann bis zum Blendrahmenprofil erweitert werden.

Auch das Oberteil des HFP-Systems muss in die Fassade eingebaut werden. Die Fassade wird durch eine Konstruktion getragen, die das System auch vor Einbruch schützt.

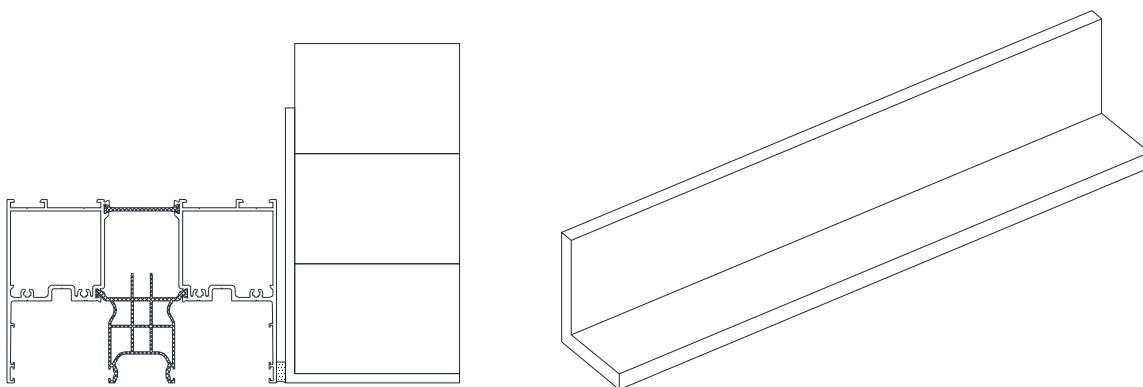

Das RC2-Zertifikat wurde für P4A glas (EN 356) und ein eingebautes System abgegeben. Das System wurde als ein integraler Bestandteil des Gebäudes entwickelt und entsprechend getestet. Wenn das Element nicht nach diesen Richtlinien eingebaut wird, ist das RC2-Zertifikat nicht gültig.

Die Befestigung am Baukörper erfolgt durch systemabhängige Befestigungsanker, Rohrrahmendübel oder andere Befestigungsteile. Beim Einsatz von Schrauben und Dübeln ist zu gewährleisten, dass die Mindestabstände gemäß den Verarbeitungsrichtlinien der Befestigungshersteller eingehalten werden. Die Verankerung ist so zu wählen, dass die auf das Schiebeelement einwirkenden Lasten sicher an den Baukörper abgeleitet werden. Alle zum Einsatz kommenden



Verankerungen sollen aus Aluminium oder Edelstahl bzw. korrosionsgeschützt sein, damit die Aluminiumprofile nicht angegriffen werden.

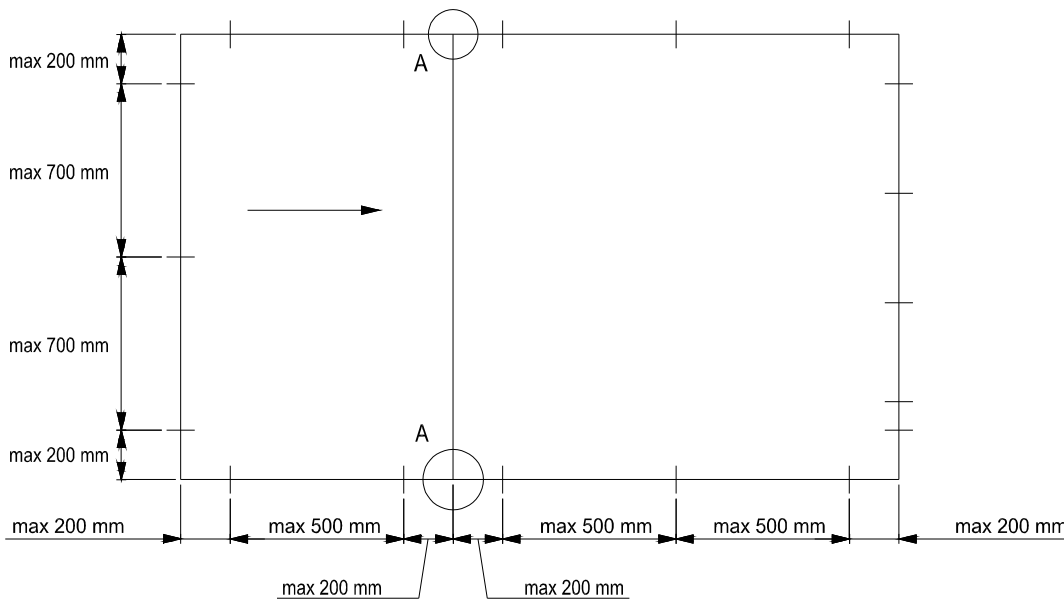

Die Anzahl der Befestigungspunkte ist wie folgt festzulegen:

- Je Rahmenseite müssen mind. zwei Befestigungen eingebracht werden.
- Der max. Abstand zur Rahmenecke darf 200 mm nicht unterschreiten.
- Der max. Abstand der Befestigungspunkte untereinander darf 700 mm (500 mm bei Unterleiste) nicht unterschreiten.
- Wo Wechselprofile sich zwischen Ober- und Unterleisten befinden, sind die Befestigungspunkte ebenfalls in höchstens 200 mm Abstand von der Mitte der Wechselprofile anzubringen (A).
- Die Unterleiste muss in jedem Fall abgestützt werden, um Durchbiegen zu verhindern.

Anmerkung: Die Befestigungen sollen so angebracht werden, dass ein eventuelles Arbeiten der Aluminiumelemente aufgenommen werden kann.

Beim Einsatz von Schrauben und Dübeln durch die Profile dürfen die Kammern im Unterblendrahmen nicht durchbohrt werden um Wassereindringung im Bereich dieser Befestigung zu vermeiden.

## II.2.2 Einbau der Beschläge

Das verklebte Glas hat an jeder Seite eine Öffnung zum Anbringen von Beschlägen. Nach Einbau aller Artikel und Profile sind diese Öffnungen unsichtbar.

Weitere Informationen über die Installation der Zubehörteile und ihre Einstellbarkeit finden sich im Katalog, auf der Artikel-Website oder im Dokumentationsmaterial in der Verpackung des betreffenden Artikels.

Die Auswahl der Beschläge hat entsprechend den Vorgaben des Systemlieferanten bzw. des Herstellers der Beschläge zu erfolgen. Die hier angegebenen Werte bzgl. der max. Flügelabmessungen, des max. Flügelgewichtes, der Anzahl der Verschlusspunkte sind einzuhalten. Bewegliche Teile sind, entsprechend den Angaben des Beschlagherstellers, mit säurefreiem Fett zu versehen. Eine Funktionsprüfung der Beschläge ist nach erfolgter Fertigung und Montage unerlässlich.

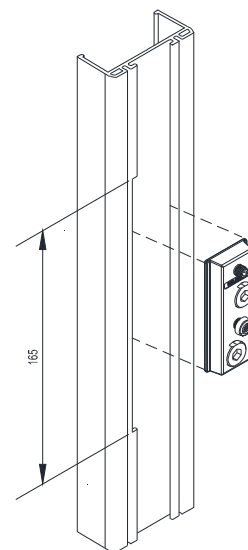

### II.3 VERGLASUNG

Ein von Reynaers anerkannter Glaslieferant verklebt das Glas mit den Verbundprofilen, auf Bestellung von Reynaers mit einem standardisierten Bestellformular. Das verklebte Glas hat an jeder Seite eine Öffnung zum Montieren des Beschlags.

Wo ein Griff angebracht werden muss (Positionen können im Auftragsformular für das Hi-Finity-Glas angegeben werden), wird das Verbundprofil unterbrochen. Nach dem Anbringen des Griffs kann die Öffnung mit einer Abdeckkappe verschlossen werden. Die Abdeckkappen müssen mit einem Dichtungsmittel von Dow Corning (z. B. DC895) oder einem gleichwertigen Produkt, das mit der Glasverklebung verträglich ist, an der verklebten Glasscheibe befestigt werden.

Es gibt mehrere unterschiedliche Glastypen je nach Typ der Konfiguration, für die Sie sich entschieden haben. Zur unkomplizierten Kommunikation haben wir jedem Typ einen anderen Buchstaben gegeben (alle Ansichten sind von außerhalb des Gebäudes gesehen):

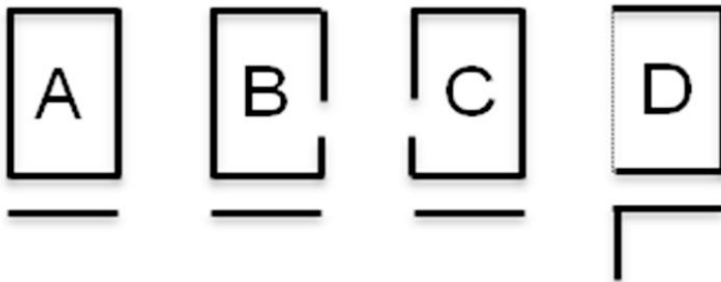

- A: Glas ohne Griff
- B: Glas mit Griff rechts
- C: Glas mit Griff links
- D: Glas für feste Ecken (beide Seiten)

Maße des Glases bzw. Maße des fertigen Produkts:

Im Bestellformular, das aus Ihrer Reynapro-Datei erstellt wird, sind die Glasmaße vor dem Prozess der Strukturverglasung angegeben. Bei den Maßen im (Online-)Katalog sind auch die Glasmaße vor der Strukturverglasung angegeben.

Das fertige Produkt ist das Glas mit einem an ihm verklebten strukturverglasten (Verbund-)Rahmen, der andere Abmessungen als das Glas selbst hat. Zur Kontrolle Ihrer Bestellung können Sie sich an diese Richtlinien halten:

Im Fall von Type A, B oder C:

- Für HFP 147: Glasmaße + 19 mm (Breite und Höhe) +/-1 mm Toleranz

Im Fall von Typ D (konstruktive Verbindung):

- Für den Auftrag ist eine detaillierte Zeichnung der Konfiguration erforderlich.
- Für HFP 147: Glasmaße + 19 mm (Breite und Höhe) +/-1 mm Toleranz
- Diese Glasscheiben werden vor Ort vom Glaslieferanten verklebt.

Wenn das Glas nicht in den Toleranzen liegt, wenden Sie sich am besten an Ihren Ansprechpartner bei Reynaers.



## III. MONTAGE REIHENFOLGE HFP 147

1 KEUZE CONFIGURATIE  
 CHOIX DE CONFIGURATION  
 CONFIGURATION SELECT  
 WAHL KONFIGURATION

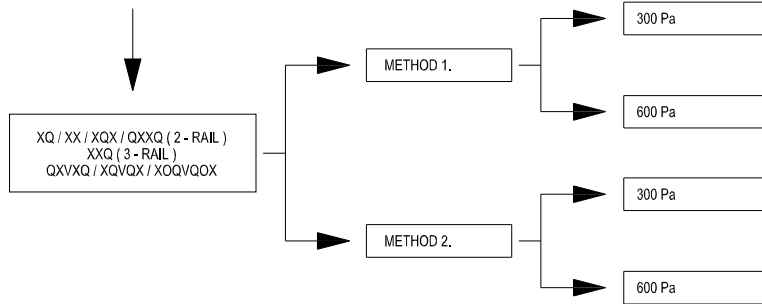

2 ZAGEN  
 SCIER  
 SAWING  
 SAEGEN

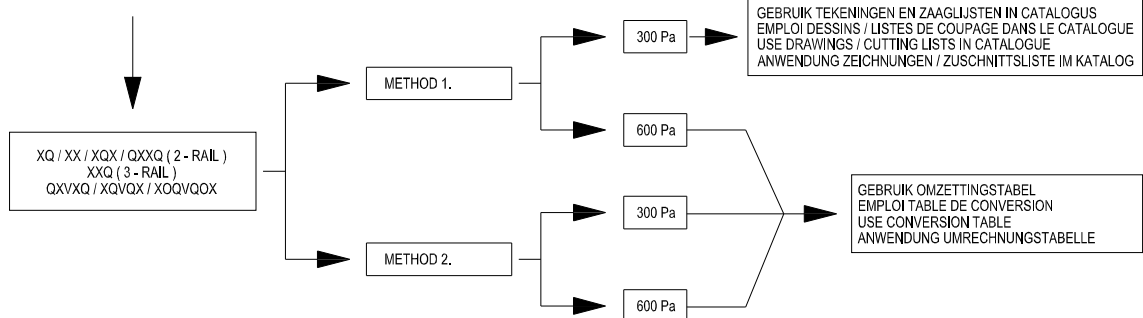

3 FREZEN  
 FRAISE  
 MILLING  
 FRAESE

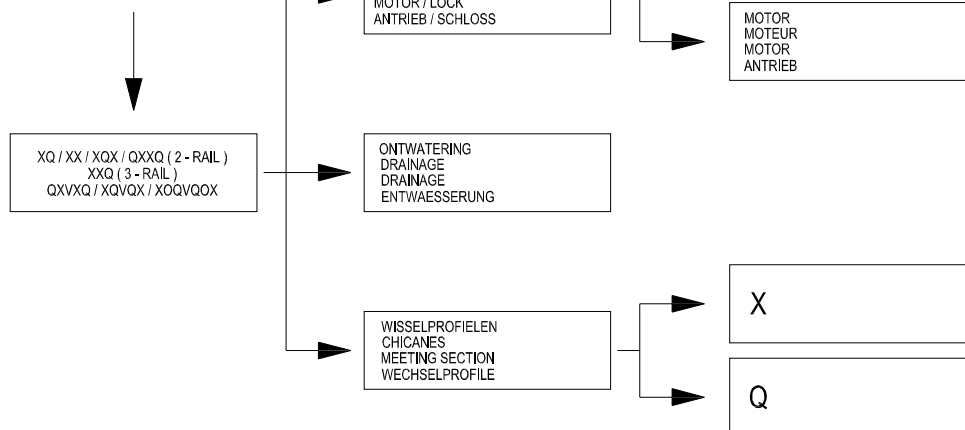

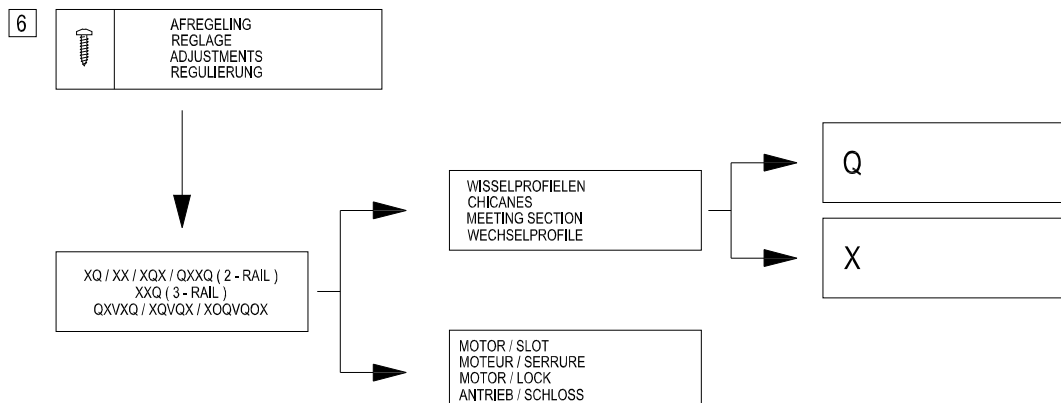
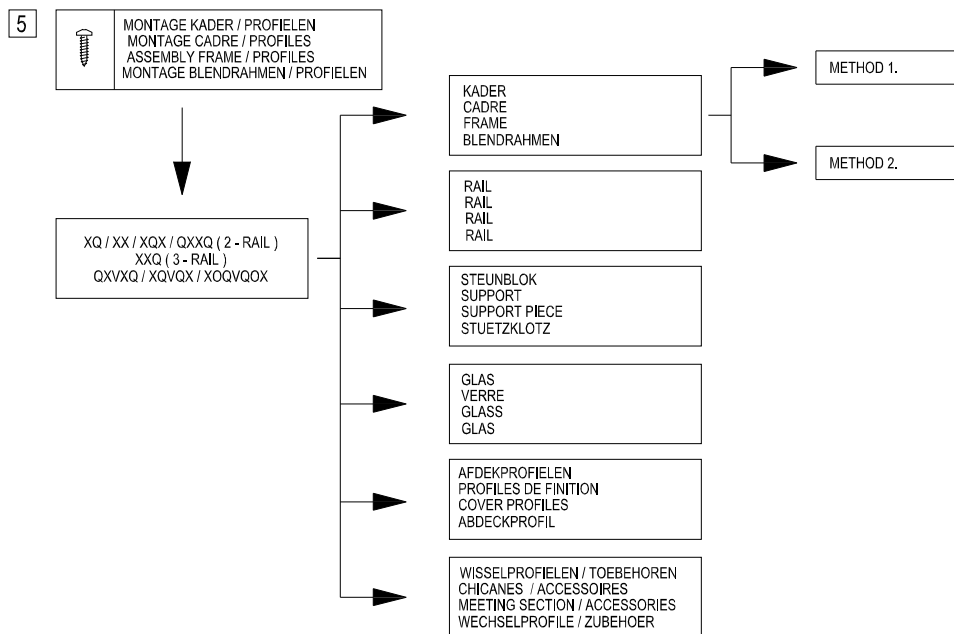
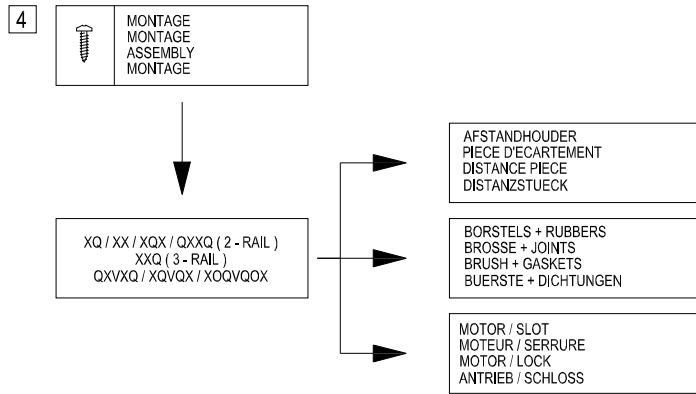



C



Profielen





Profilés

Profiles

Profile





Art. N°			Art. N°		
030.0138.00	25D.C.004	D0092897			
034.0420.XX	25D.C.009	D0095021			
106.0083.17	25D.C.009	D0095021			
106.0085.17	25D.C.009	D0095021			
106.0090.XX	25D.C.009	D0095021			
106.0360.XX	25D.C.010	D2000446			
106.0361.XX	25D.C.011	D2000447			
106.0375.--	25D.C.004	D0092897			
106.0389.04	25D.C.008	D0095019			
106.0397.XX	25D.C.006	D0092898			
106.0398.XX	25D.C.006	D0092898			
106.1383.XX	25D.C.003	D0092895			
106.1385.XX	25D.C.004	D0092897			
106.1387.XX	25D.C.007	D0092899			
106.1388.XX	25D.C.007	D0092899			
106.1389.XX	25D.C.008	D0095019			
106.1390.XX	25D.C.008	D0095019			
106.1394.XX	25D.C.003	D0092895			
106.1395.XX	25D.C.003	D0092895			
106.1399.XX	25D.C.005	D0095183			
106.1400.XX	25D.C.005	D0095183			



BUITENKADER  
 DORMANT  
 OUTER FRAME  
 BLENDRAHMEN

			$\frac{A}{dm^2/m}$	$\frac{P}{dm^2/m}$	$L_m$	$I_x \text{ cm}^4$	$I_y \text{ cm}^4$
106.1383.XX			56.85	39.3	7.00	168.053	23.852
106.1385.XX			63.25	45.7	7.00	207.973	81.062

			$\frac{A}{dm^2/m}$	$\frac{P}{dm^2/m}$	$L_m$	$I_x \text{ cm}^4$	$I_y \text{ cm}^4$
KOPPELPROFIEL PROFILE DE RACCORDEMENT CONNECTION PROFILE KUPPLUNGSPROFIL							
030.0138.00			-	-	7.00	-	-

WISSELPROFIEL  
 CHICANE  
 MEETING SECTION  
 WECHSELPROFIL

			$\frac{A}{dm^2/m}$	$\frac{P}{dm^2/m}$	$L_m$	$I_x \text{ cm}^4$	$I_y \text{ cm}^4$
106.1387.XX			31.22	11.5	4.00	44.779	3.492
106.1388.XX			36.34	16.1	4.00	97.745	7.850
106.1389.XX			44.03	24.2	4.00	205.918	12.593

AFDEKPROFIEL  
 PROFILE DE RECOUVREMENT  
 COVERING PROFILE  
 ABDECKPROFIL

			$\frac{A}{dm^2/m}$	$\frac{P}{dm^2/m}$	$L_m$	$I_x \text{ cm}^4$	$I_y \text{ cm}^4$
106.1390.XX			11.50	4.5	7.00	1.704	0.023
106.1394.XX			25.06	9.2	7.00	15.790	0.202
106.1395.XX			12.76	3.9	7.00	1.107	0.146

BUITENKADER 3-RAIL  
DORMANT 3-RAIL  
OUTER FRAME 3-RAIL  
BLENDRAHMEN 3-RAIL

			$\frac{A}{dm^2/m}$	$\frac{P}{dm^2/m}$	$\leftarrow L_m \rightarrow$	$I_x \text{ cm}^4$	$I_y \text{ cm}^4$
106.1399.XX			70.04	45.1	7.00	531.805	26.881
106.1400.XX			76.44	51.5	7.00	661.750	102.465

AFSTANDSHOUDER  
REDUCTEUR DE FEUILLURE  
FILLISTER REDUCER  
FALZVERKLEINUNGSPROFIL

			$\frac{A}{dm^2/m}$	$\frac{P}{dm^2/m}$	$\leftarrow L_m \rightarrow$	$I_x \text{ cm}^4$	$I_y \text{ cm}^4$
034.0420.XX			13.85	6.5	7.00	-	-

GOOT  
GOUTTIERE  
GUTTER  
RINNENPROFIL

			$\frac{A}{dm^2/m}$	$\frac{P}{dm^2/m}$	$\leftarrow L_m \rightarrow$	$I_x \text{ cm}^4$	$I_y \text{ cm}^4$
106.0083.17			67.14	-	7.00	57.896	47.021
106.0085.17			73.54	-	7.00	64.192	104.232
106.0090.XX			25.66	5.3	7.00	7.337	3.645

RAIL  
RAIL  
RAIL  
RAIL

			$\frac{A}{dm^2/m}$	$\frac{P}{dm^2/m}$	$\leftarrow L_m \rightarrow$	$I_x \text{ cm}^4$	$I_y \text{ cm}^4$
106.0375.--			-	-	7.00	-	-

WISSELPROFIEL KUNSTSTOF  
CHICANE MATIERE SYNTHETIQUE  
SYNTHETIC MEETING SECTION  
WECHSELPROFIL KUNSTSTOFF

			$\frac{A}{dm^2/m}$	$\frac{P}{dm^2/m}$	$\leftarrow L_m \rightarrow$	$I_x \text{ cm}^4$	$I_y \text{ cm}^4$
106.0389.04			-	-	7.00	2.201	0.814

4-SLAG PROFIEL  
PROFILE4 VANTAUX  
4 DOORS PROFILE  
4-SCHLAG PROFIL

			$\frac{A}{dm^2/m}$	$\frac{P}{dm^2/m}$	$\leftarrow L_m \rightarrow$	$I_x \text{ cm}^4$	$I_y \text{ cm}^4$
106.0397.XX			45.90	25.2	4.00	94.241	20.250

106.0398.XX			52.24	33.8	3.50	189.494	24.624
-------------	--	--	-------	------	------	---------	--------

HOEKPROFIEL 90°  
PROFILE D'ANGLE 90°  
CORNER PROFILE 90°  
ECKPROFIL 90°

			$\frac{A}{dm^2/m}$	$\frac{P}{dm^2/m}$	$\leftarrow L_m \rightarrow$	$I_x \text{ cm}^4$	$I_y \text{ cm}^4$
106.0360.XX			39.77	23.5	4.00	29.480	38.213
106.0361.XX			22.41	11.4	4.00	2.234	10.940

	A dm <sup>2</sup> /m	P dm <sup>2</sup> /m	Lm	Ix cm <sup>4</sup>	Wx cm <sup>3</sup>	ax mm	Iy cm <sup>4</sup>	Wy cm <sup>3</sup>	ay mm	
106.1383.XX	56.85	39.3	7.00	168.053	22.864	73.50	23.852	4.962	19.93	Y X 0
106.1394.XX	24.90	9.4	7.00	15.460	3.248	47.60	0.178	0.137	12.94	
106.1395.XX	12.76	3.9	7.00	1.107	0.615	18.00	0.146	0.122	11.91	

106.1383.XX

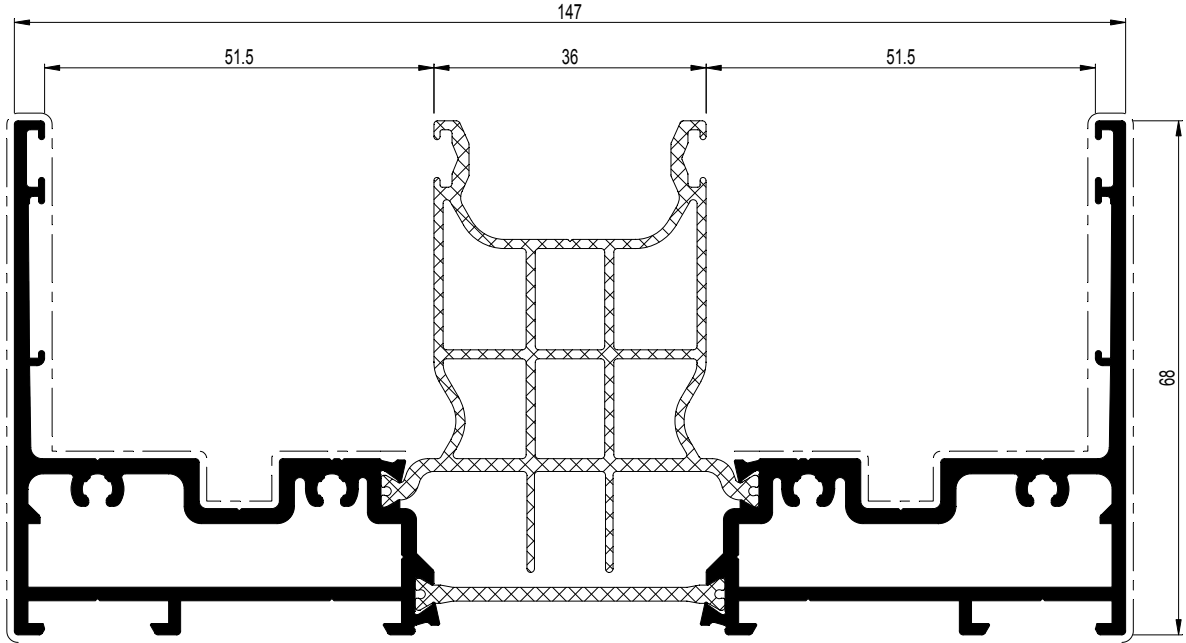

106.1394.XX

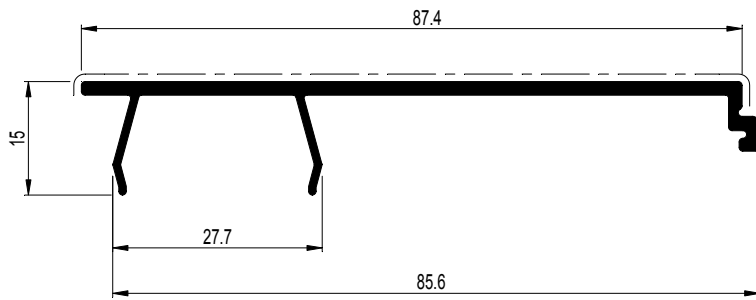

106.1395.XX

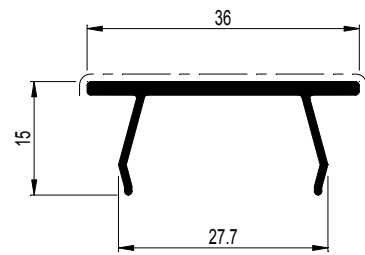

	$A$ dm <sup>2</sup> /m	$P$ dm <sup>2</sup> /m	$L_m$	$I_x$ cm <sup>4</sup>	$W_x$ cm <sup>3</sup>	$a_x$ mm	$I_y$ cm <sup>4</sup>	$W_y$ cm <sup>3</sup>	$a_y$ mm	X Y X 0
030.0138.00	-	-	7.00	-	-	-	-	-	-	
106.0375.--	-	-	7.00	-	-	-	-	-	-	
106.1385.XX	63.25	45.7	7.00	207.973	28.296	73.50	81.062	13.121	38.22	

106.1385.XX

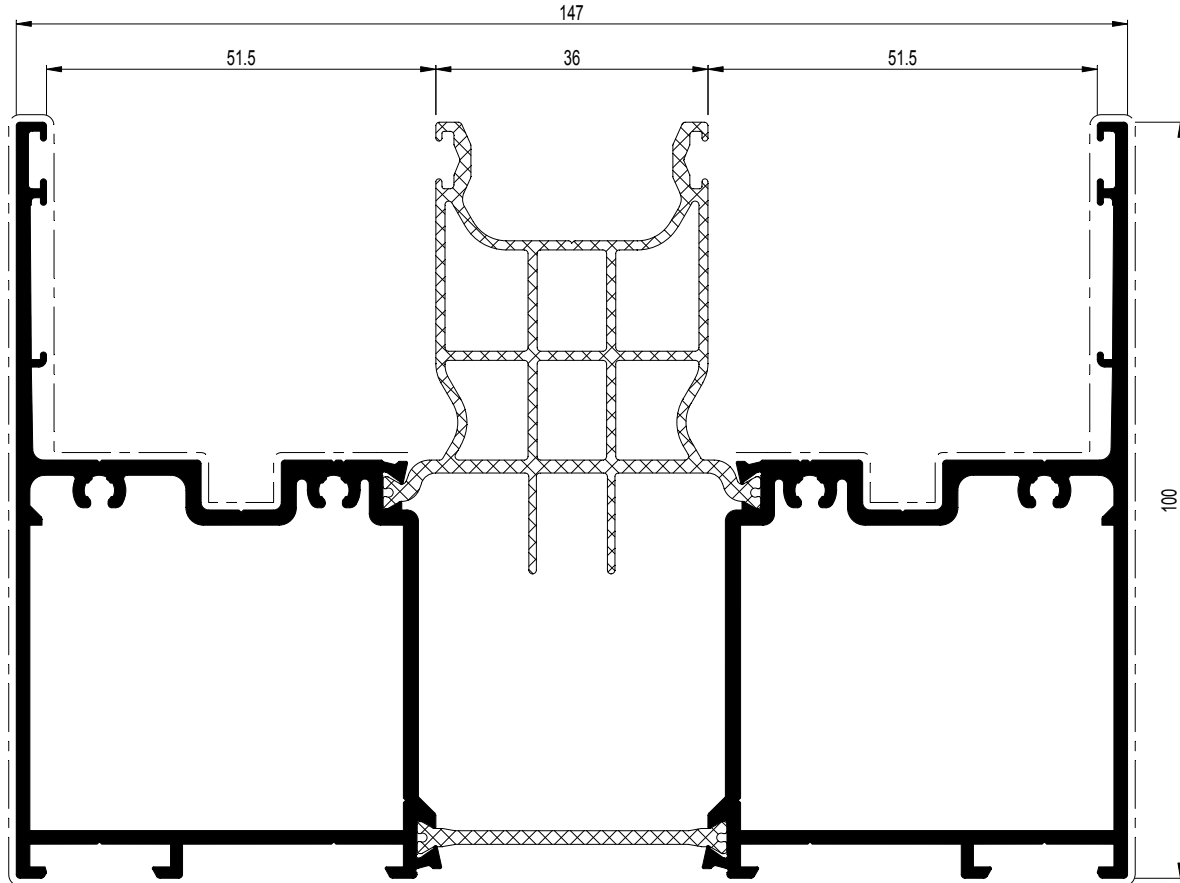

106.0375.--

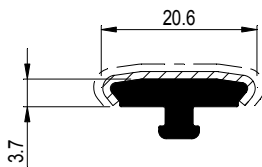

030.0138.00

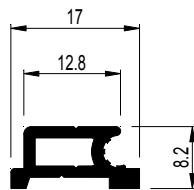



# HFP 147

BUITENKADER 3-RAIL  
 DORMANT 3-RAIL  
 OUTER FRAME 3-RAIL  
 BLENDRAHMEN 3-RAIL

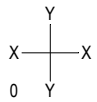

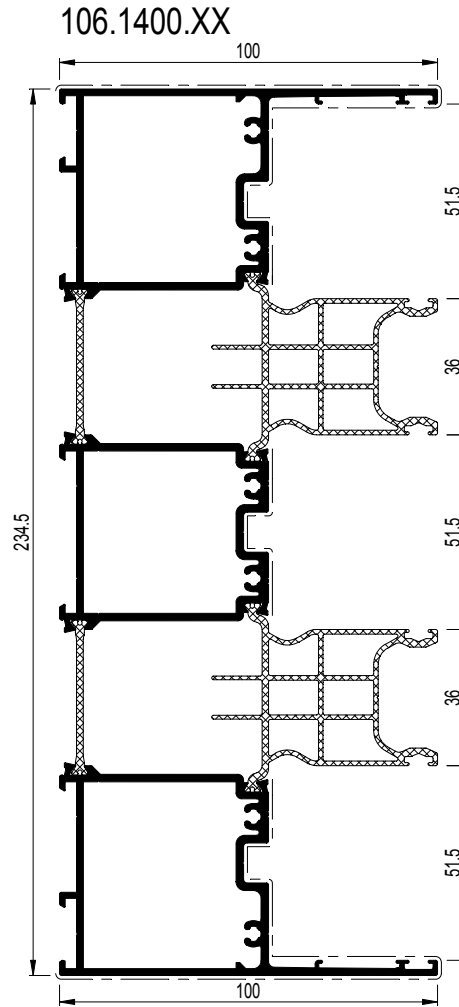
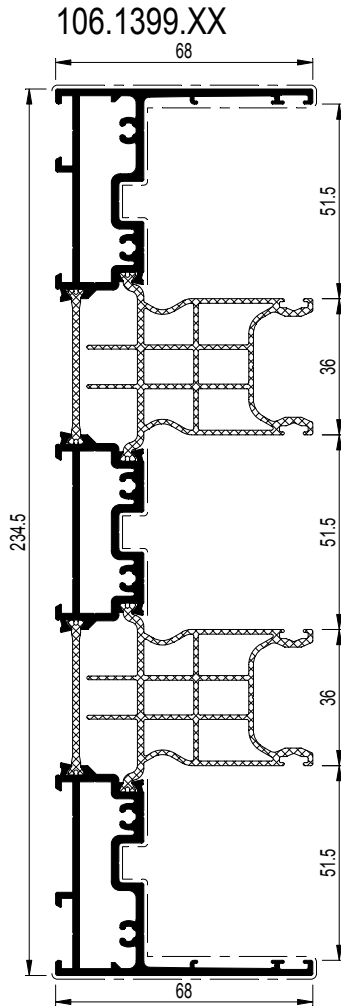
	$\frac{A}{dm^2/m}$	$\frac{P}{dm^2/m}$	$\leftarrow L_m \rightarrow$	$I_x \text{ cm}^4$	$W_x \text{ cm}^3$	$a_x \text{ mm}$	$I_y \text{ cm}^4$	$W_y \text{ cm}^3$	$a_y \text{ mm}$	
106.1399.XX	70.04	45.1	7.00	531.805	45.356	117.25	26.881	5.384	18.07	X
106.1400.XX	76.44	51.5	7.00	661.750	56.439	117.25	102.465	16.004	35.98	0 Y

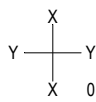

	$\frac{A}{dm^2/m}$	$\frac{P}{dm^2/m}$	$L_m$	$I_x \text{ cm}^4$	$W_x \text{ cm}^3$	ax mm	$I_y \text{ cm}^4$	$W_y \text{ cm}^3$	ay mm	
106.0397.XX	45.90	25.2	3.50	94.241	16.805	56.08	20.250	6.031	33.42	Y X 0
106.0398.XX	52.24	33.8	3.50	189.494	24.281	72.96	24.624	7.334	33.43	

106.0398.XX

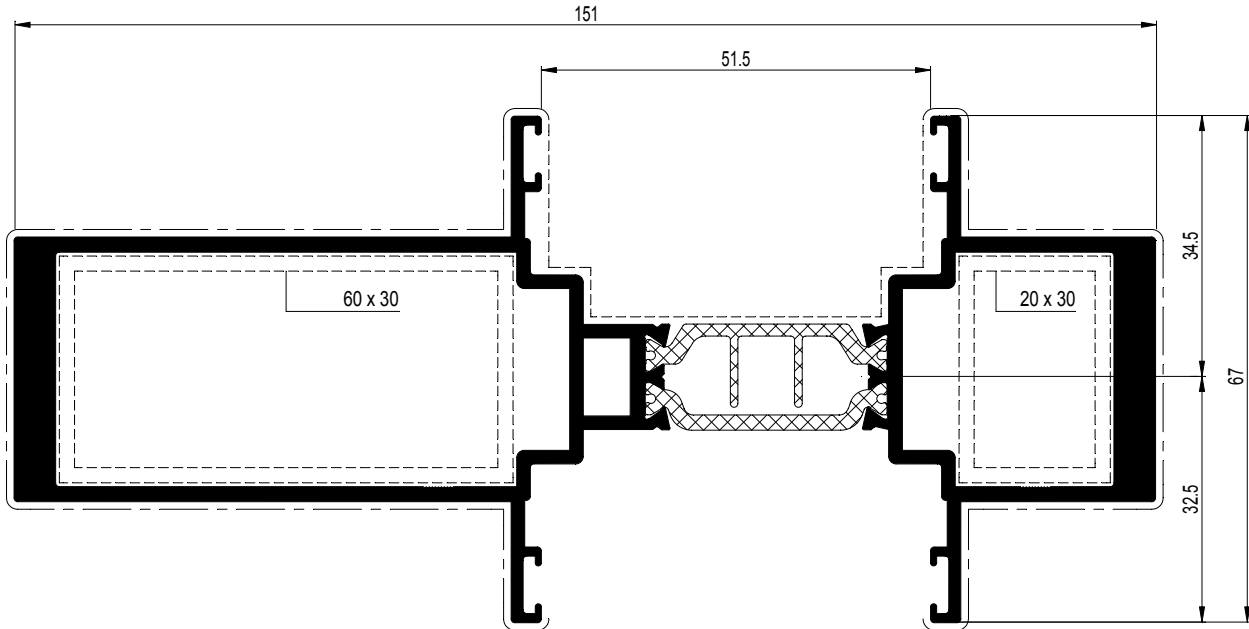

106.0397.XX

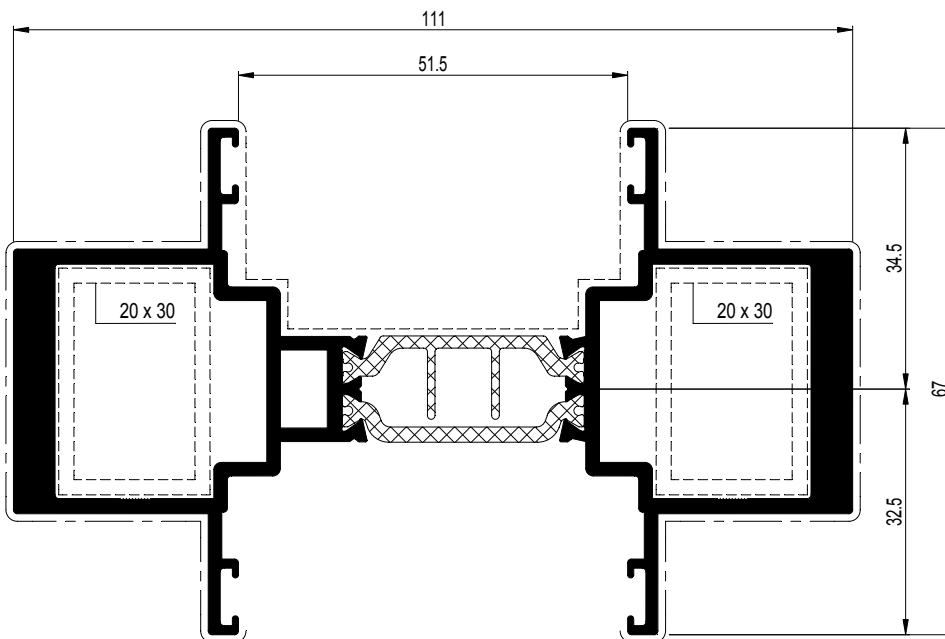



	$\frac{A}{dm^2/m}$	$\frac{P}{dm^2/m}$	$\leftarrow L_m \rightarrow$	$I_x \text{ cm}^4$	$W_x \text{ cm}^3$	$a_x \text{ mm}$	$I_y \text{ cm}^4$	$W_y \text{ cm}^3$	$a_y \text{ mm}$	
106.1387.XX	31.22	11.5	4.00	44.779	8.428	37.77	3.492	1.389	9.86	X Y
106.1388.XX	36.34	16.1	4.00	97.745	13.593	44.69	7.850	3.431	12.12	0 Y

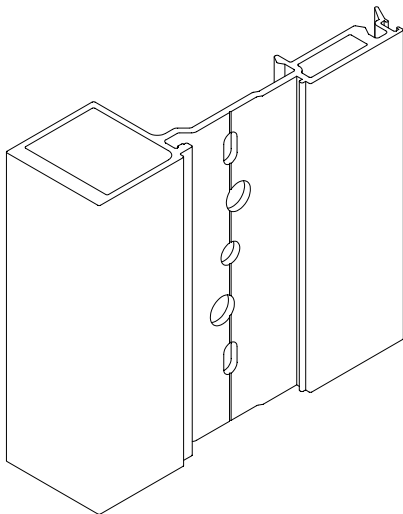
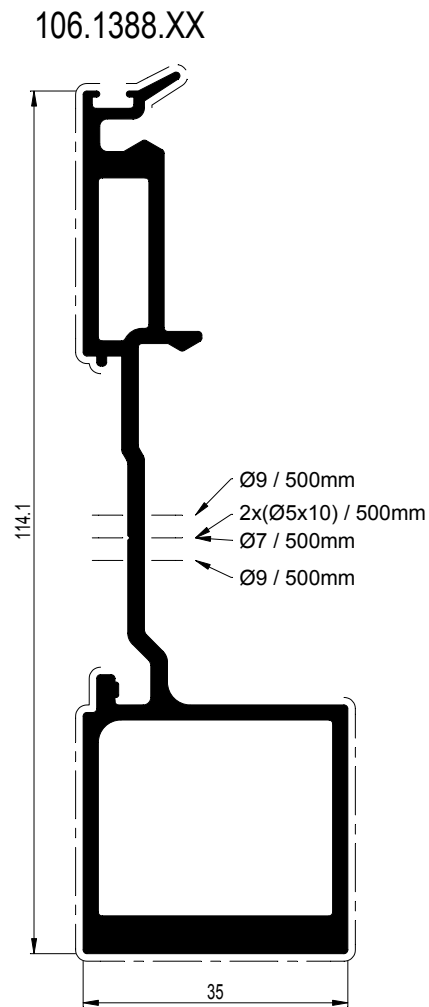
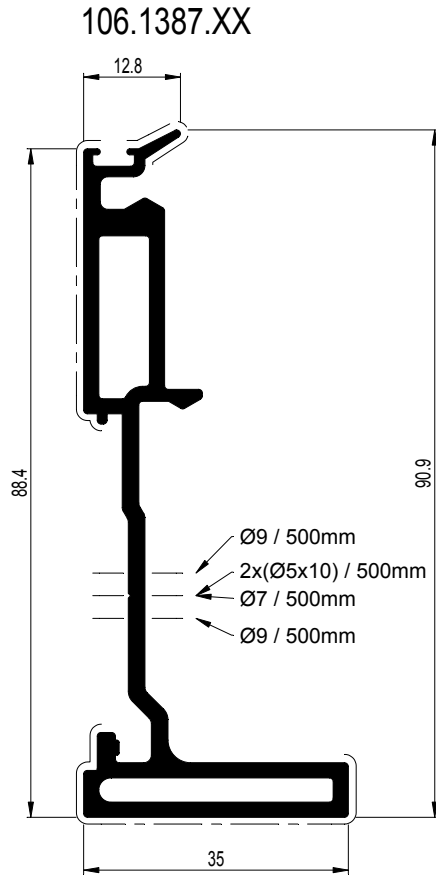

	A dm <sup>2</sup> /m	P dm <sup>2</sup> /m	L <sub>m</sub>	I <sub>x</sub> cm <sup>4</sup>	W <sub>x</sub> cm <sup>3</sup>	ax mm	I <sub>y</sub> cm <sup>4</sup>	W <sub>y</sub> cm <sup>3</sup>	ay mm	
106.0389.04	-	-	7.00	2.201	1.016	20.03	0.814	0.385	12.21	
106.1389.XX	44.03	24.2	4.00	205.918	22.521	63.57	12.593	5.779	13.21	
106.1390.XX	11.50	4.5	7.00	1.704	0.709	20.75	0.023	0.042	1.50	

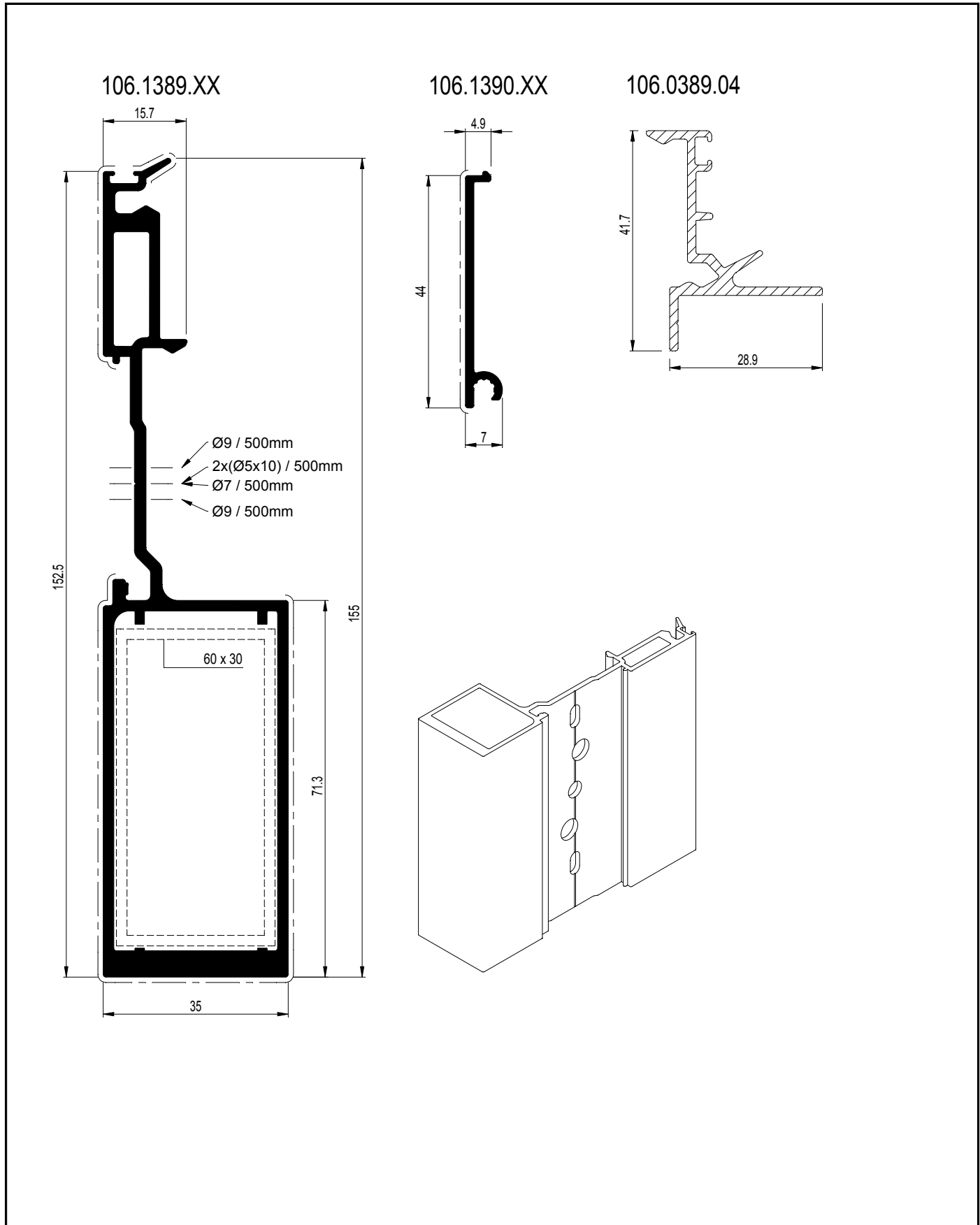

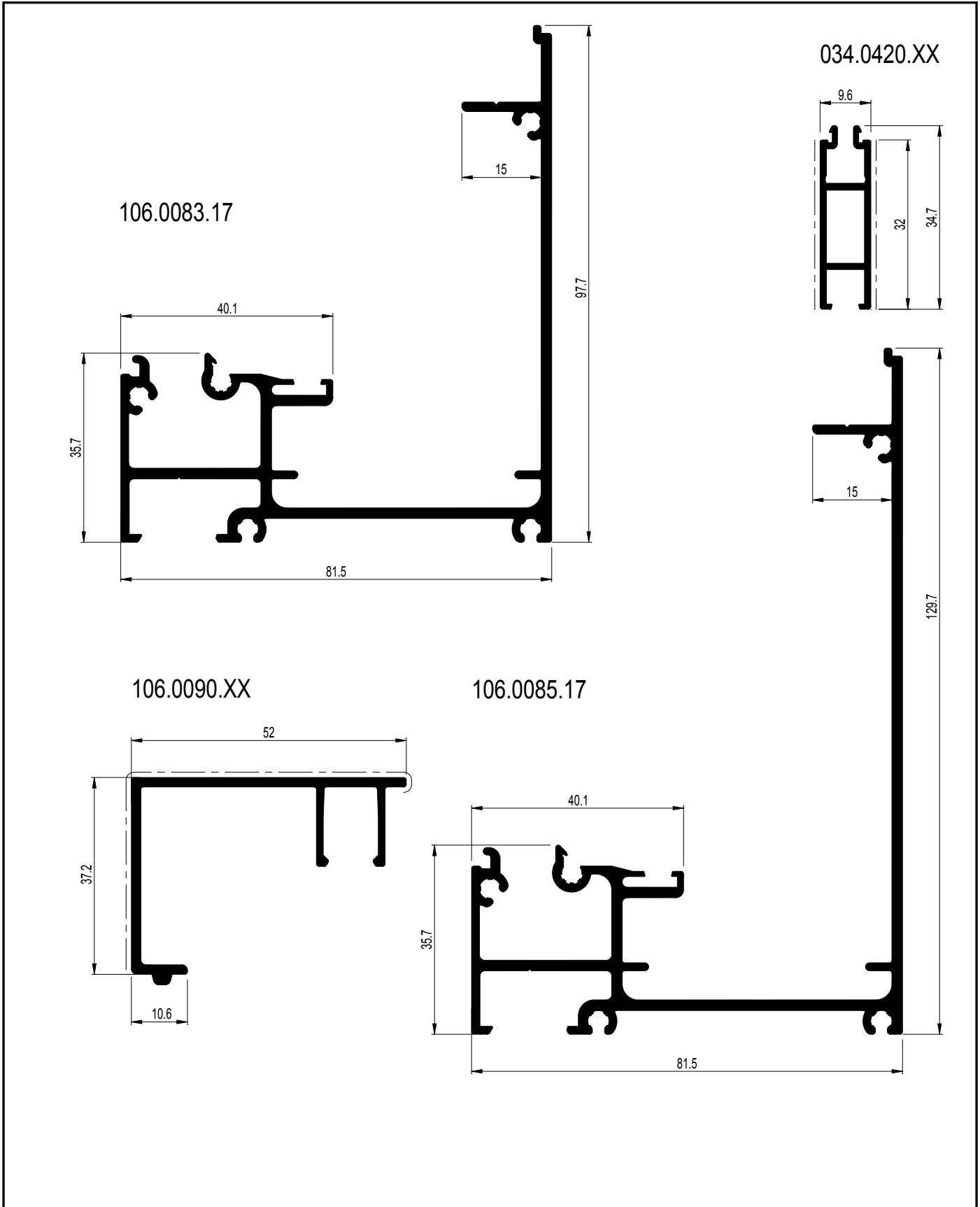

	$\frac{A}{dm^2/m}$	$\frac{P}{dm^2/m}$	$\leftarrow L_m \rightarrow$	$I_x \text{ cm}^4$	$W_x \text{ cm}^3$	ax mm	$I_y \text{ cm}^4$	$W_y \text{ cm}^3$	ay mm	
034.0420.XX	13.85	6.5	7.00	-	-	-	-	-	-	
106.0083.17	67.14	-	7.00	57.896	12.149	33.85	47.021	6.839	28.94	
106.0085.17	73.54	-	7.00	64.192	12.679	30.88	104.232	11.408	38.33	
106.0090.XX	25.66	5.3	7.00	7.337	2.280	32.17	3.645	1.314	27.74	

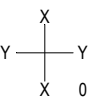

	$A$ dm <sup>2</sup> /m	$P$ dm <sup>2</sup> /m	$L_m$	$I_x$ cm <sup>4</sup>	$W_x$ cm <sup>3</sup>	$a_x$ mm	$I_y$ cm <sup>4</sup>	$W_y$ cm <sup>3</sup>	$a_y$ mm	
106.0360.XX	39.77	23.5	4.00	29.480	7.218	34.16	38.213	5.936	64.38	

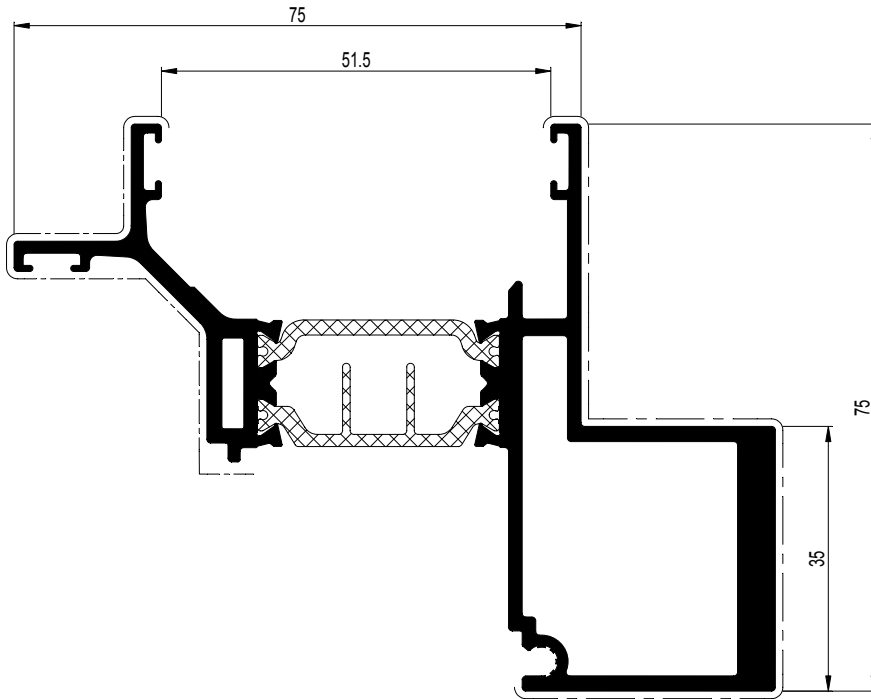
106.0360.XX

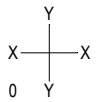

	$\frac{A}{dm^2/m}$	$\frac{P}{dm^2/m}$	$\leftarrow L_m \rightarrow$	$I_x \text{ cm}^4$	$W_x \text{ cm}^3$	ax mm	$I_y \text{ cm}^4$	$W_y \text{ cm}^3$	ay mm	
106.0361.XX	22.41	11.4	4.00	2.234	1.064	8.00	10.940	2.640	41.44	

106.0361.XX

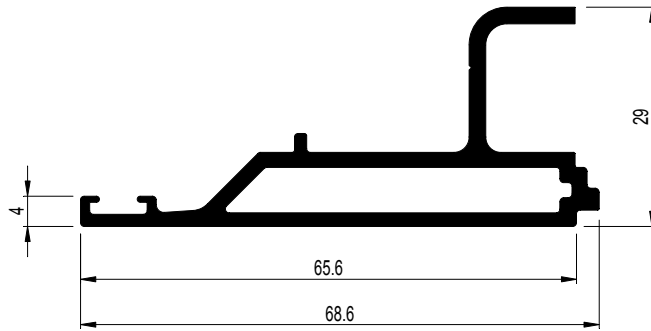

**HFP 147**  
**HFP 179**

HOEKPAAL  
PROFILE D'ANGLE  
CORNER PROFILE  
ECKPROFIL



**E**

**R**  
**REYNAERS**  
aluminium

Werktekeningen  
Coupes et débits  
Work drawings  
Werkzeichnungen







METHOD 1  
300 Pa

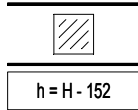

AS SHOWN ON ALL  
E-PAGES

			#	$\leftarrow L_m$	
106.1383.XX			2	H - 32	25D.C. ...
			1	B - 49	
106.1385.XX			1	B - 49	25D.C. ...
106.1399.XX			2	H - 32	25D.C. ...
			1	B - 49	
106.1400.XX			1	B - 49	25D.C. ...
106.1394.XX			2	B1 - 85	25D.C. ...
			1	H - 79	25D.C. ...
			1	H - 168	25D.C. ...
106.0389.04			1	H - 172	25D.C. ...
			1	H - 178	
106.1388.XX			1	H - 172	25D.C. ...
106.1390.XX			1	H - 172	25D.C. ...
			1	H - 114	

		#	
062.9310.04		2	25D.G. ...

METHOD 2  
300 Pa

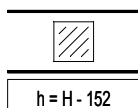

			#	$\leftarrow L_m$	
106.1383.XX			2	H	25D.C. ...
			1	B - 49	
106.1385.XX			1	B - 49	25D.C. ...
106.1399.XX			2	H	25D.C. ...
			1	B - 49	
106.1400.XX			1	B - 49	25D.C. ...
106.1394.XX			2	B1 - 85	25D.C. ...
			1	H - 79	25D.C. ...
			1	H - 168	25D.C. ...
106.0389.04			1	H - 172	25D.C. ...
			1	H - 178	
106.1388.XX			1	H - 172	25D.C. ...
106.1390.XX			1	H - 172	25D.C. ...
			1	H - 114	

		#	
062.9310.04		0	25D.G. ...



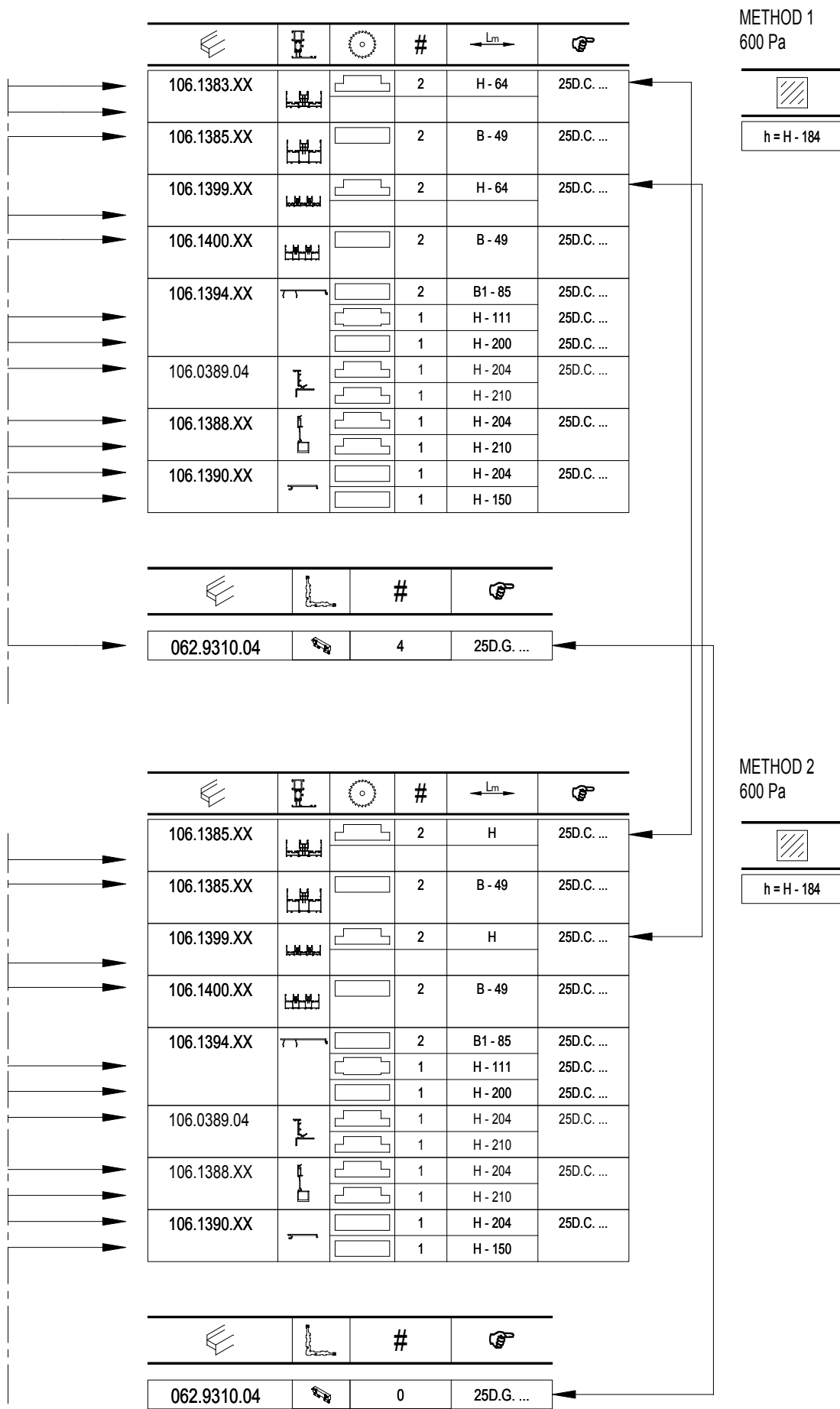

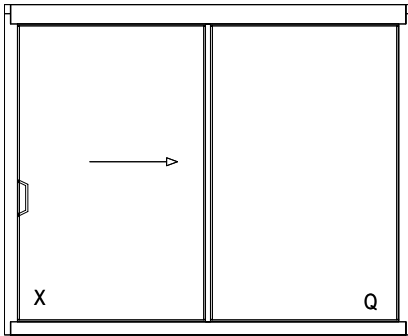

schaal - échelle  
scale - Maßstab  
1/2  
D0095238

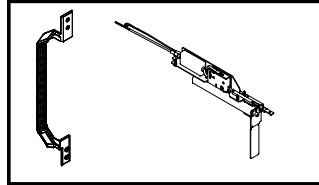







MANUELE CONFIGURATIE  
 CONFIGURATION MANUELE  
 MANUAL CONFIGURATION  
 MANUELE KONFIGURATIE



		#	
052.5321.--		16	25D.G. ...
052.5315.--		0	25D.G. ...
062.7775.XX		2	25D.G. ...





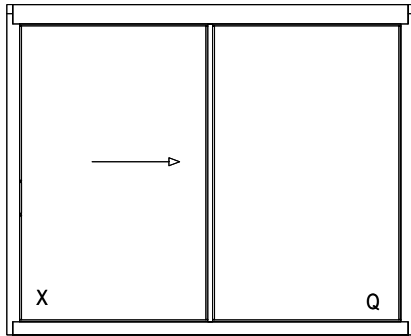

062.8226.--		1	25D.G. ...
-------------	--	---	------------

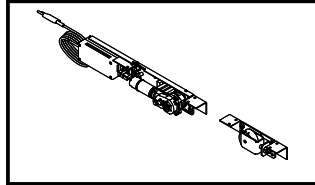





	<ul style="list-style-type: none"> <li>- SLOT ENKEL TE BEDIENEN BIJ VOLLEDIG GESLOTEN DEUR</li> <li>- EXCLUSIEF VOEDING (220/230V -&gt; 12V DC, MIN. 6W/1A)</li> <li>- EXCLUSIEF SCHAKELAAR: PULSCONTACT</li> <li>- EXCLUSIEF BACKUP SYSTEEM BIJ STROOMUITVAL</li> </ul>
	<ul style="list-style-type: none"> <li>- LA SERRURE FONCTIONNE SEULEMENT QUAND LA PORTE EST ENTIEREMENT FERMÉE</li> <li>- ALIMENTATION EXCLUSIF (220/230V -&gt; 12V DC, MIN. 6W/1A)</li> <li>- INTERRUPTEUR EXCLUSIF: CONTACT A IMPULSION</li> <li>- SYSTEME BACKUP EN CAS D'INTERRUPTION D'ALIMENTATION EXCLUSIF</li> </ul>
	<ul style="list-style-type: none"> <li>- LOCK ONLY OPERATES WHEN DOOR IS FULLY CLOSED</li> <li>- SUPPLY EXCLUSIVE (220/230V -&gt; 12V DC, MIN. 6W/1A)</li> <li>- SWITCH EXCLUSIVE: PULSE CONTACT</li> <li>- POWER FAILURE BACKUP EXCLUSIVE</li> </ul>
	<ul style="list-style-type: none"> <li>- SCHLOSS NUR BEI VOLLSTÄNDIG GESCHLOSSENER TÜR ZU BETÄTIGEN</li> <li>- EXKLUSIV BETRIEBSSPANNUNG (220/230V -&gt; 12V DC, MIN. 6W/1A)</li> <li>- EXKLUSIV SCHALTER: IMPULSKONTAKT</li> <li>- EXKLUSIV BACKUP STROMAUSFALL</li> </ul>







MOTORISCHE CONFIGURATIE  
 CONFIGURATION MOTEUR  
 MOTOR CONFIGURATION  
 MOTOR KONFIGURA



		#	
052.5321.--		14	25D.G. ...
052.5315.--		2	25D.G. ...
062.7775.XX		0	25D.G. ...

062.8200/1.--		1	25D.G. ...
062.8210.--		1	25D.G. ...
062.8220.--		1	25D.G. ...
062.8195.07		1	25D.G. ...
062.8205.XX		1	25D.G. ...
052.5300.--		4	25D.G. ...

	<ul style="list-style-type: none"> <li>- SLOT SLUIT ALTIJD BIJ VOLLEDIG DICHTGESCHOVEN VLEUGEL</li> <li>- INCLUSIEF VOEDING (220/230V -&gt; 24V) + MECHANISCHE OVERRIDE BIJ STROOMUITVAL</li> <li>- SCHAKELAAR: PULSCONTACT</li> <li>- NIET VOOR SCHUIVENDE DELEN AAN BUITENZIJDE</li> </ul>
	<ul style="list-style-type: none"> <li>- LA SERRURE SE FERME TOUJOURS COMPLÈTEMENT QUAND L'OUVRANT EST FERMÉ</li> <li>- ALIMENTATION INCLUSIF (220/230V -&gt; 24V) + SÉCURITÉ MECANIQUE EN CAS D'INTERRUPTION D'ALIMENTATION</li> <li>- INTERRUPTEUR: CONTACT À IMPULSION</li> <li>- PAS POUR DES PARTIES COULISSANTES À L'EXTÉRIEUR</li> </ul>
	<ul style="list-style-type: none"> <li>- LOCK ALWAYS CLOSES WHEN VENT IS FULLY CLOSED</li> <li>- SUPPLY INCLUDED (220/230V -&gt; 24V) + MANUAL OVERRIDE IN CASE OF POWER FAILURE</li> <li>- SWITCH: PULSE CONTACT</li> <li>- NOT FOR SLIDING VENTS OUTSIDE</li> </ul>
	<ul style="list-style-type: none"> <li>- SCHLOSS SCHLIESST IMMER VOLLSTÄNDIG BEI ZUGESCHOBENEM FLÜGEL</li> <li>- INKLUSIEF BETRIEBSSPANNUNG (220/230V -&gt; 24V) + MECHANISCHE UNTKUPPLUNG BEIM STROMAUSFALL</li> <li>- SCHALTER: IMPULSKONTAKT</li> <li>- NICHT FÜR SCHIEBETEILE AN AUßENSEITE</li> </ul>

2-RAIL  
2-RAIL

2-RAIL  
2-RAIL

Fg max (X) ≤ 500 KG  
B (X) ≤ B (Q)

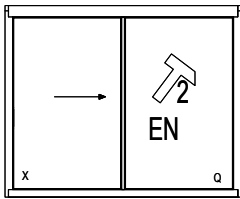

DIN R

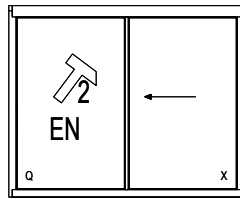
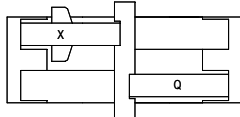

DIN L

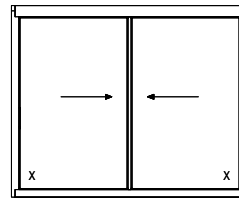
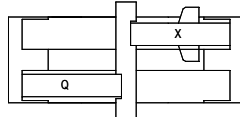

DIN L / R

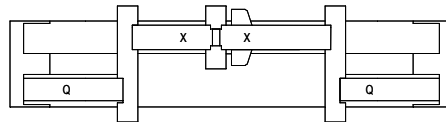
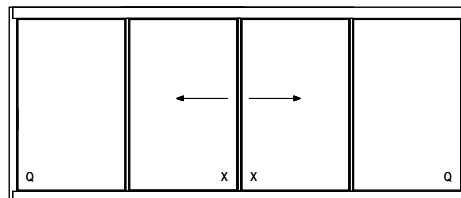
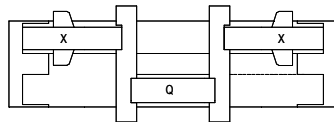
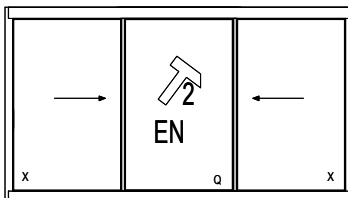
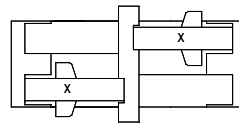
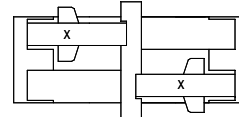

3-RAIL  
3-RAIL

3-RAIL  
3-RAIL

Fg max (X + O) ≤ 500 KG  
B (O) ≤ B (Q)

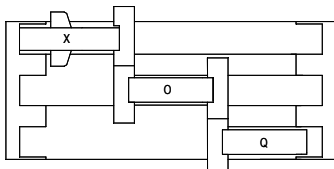
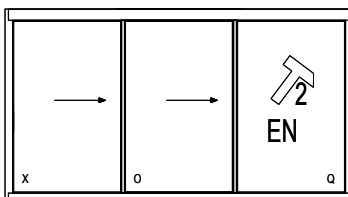

B(X) = B(O)



Testen uitgevoerd volgens norm EN 1627-1630  
 Essais effectués par conformément la norme EN 1627-1630  
 Tests carried out according to standard EN 1627-1630  
 Einbruchhemmende Prüfungen gemäß Norm EN 1627-1630

X : PRIMAIRE VLEUGEL  
 Q : VASTE VLEUGEL  
 O : SECUNDAIRE VLEUGEL  
 V : HOEKOPLOSSING

X : OUVRANT PRIMAIRE  
 Q : OUVRANT FIXE  
 O : OUVRANT SECONDAIRE  
 V : SOLUTION ANGULAIRE

X : PRIMARY SLIDING VENT  
 Q : FIXED VENT  
 O : SECONDARY SLIDING VENT  
 V : CORNER SOLUTION

X : GANGFLUEGEL  
 Q : FENSTER FLUEGEL  
 O : STANDFLUEGEL  
 V : ECKLÖSUNG

	2-RAIL 2-RAIL	2-RAIL 2-RAIL	Fg max (X) ≤ 300 KG B (X) ≤ B (Q)
--	------------------	------------------	--------------------------------------

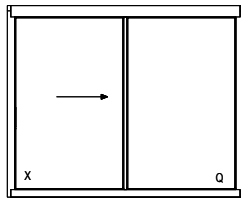

DIN R

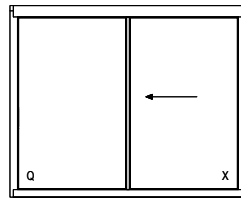
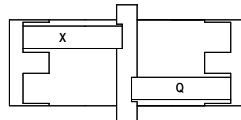

DIN L

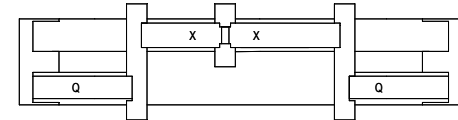
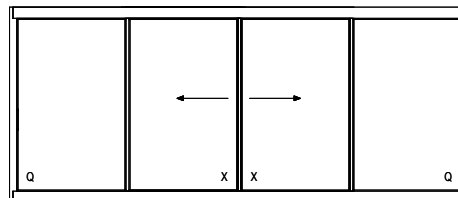
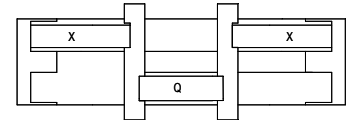
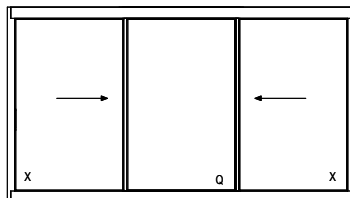
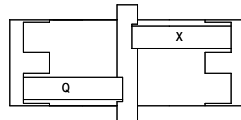

$$B(Q) \geq B1 + B3$$

	3-RAIL 3-RAIL	3-RAIL 3-RAIL	Fg max (X + O) ≤ 300 KG B (O) ≤ B (Q)
--	------------------	------------------	--

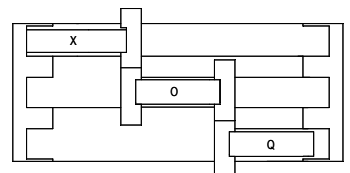
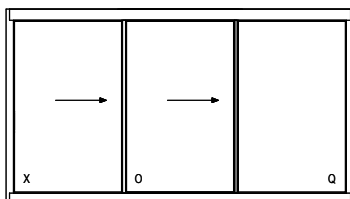

$$B(X) = B(O)$$

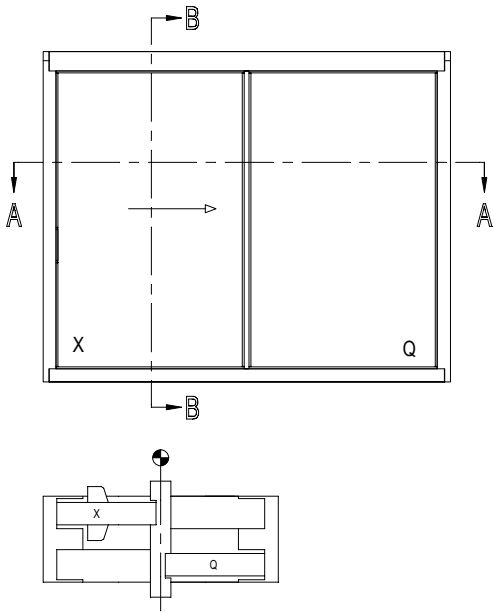

			#	← Lm →	
106.1383.XX			2	H - 32	25D.C. ...
			1	B - 49	
106.1385.XX			1	B - 49	25D.C. ...
106.1394.XX			2	B1 - 85	25D.C. ...
			1	H - 79	25D.C. ...
			1	H - 168	25D.C. ...
106.1395.XX			2	B2 - 85	25D.C. ...
106.0389.04			1	H - 172	25D.C. ...
			1	H - 178	
106.1388.XX			1	H - 172	25D.C. ...
			1	H - 178	
106.1390.XX			1	H - 172	25D.C. ...
			1	H - 114	
106.0375.--			1	B - 48	25D.C. ...

A - A

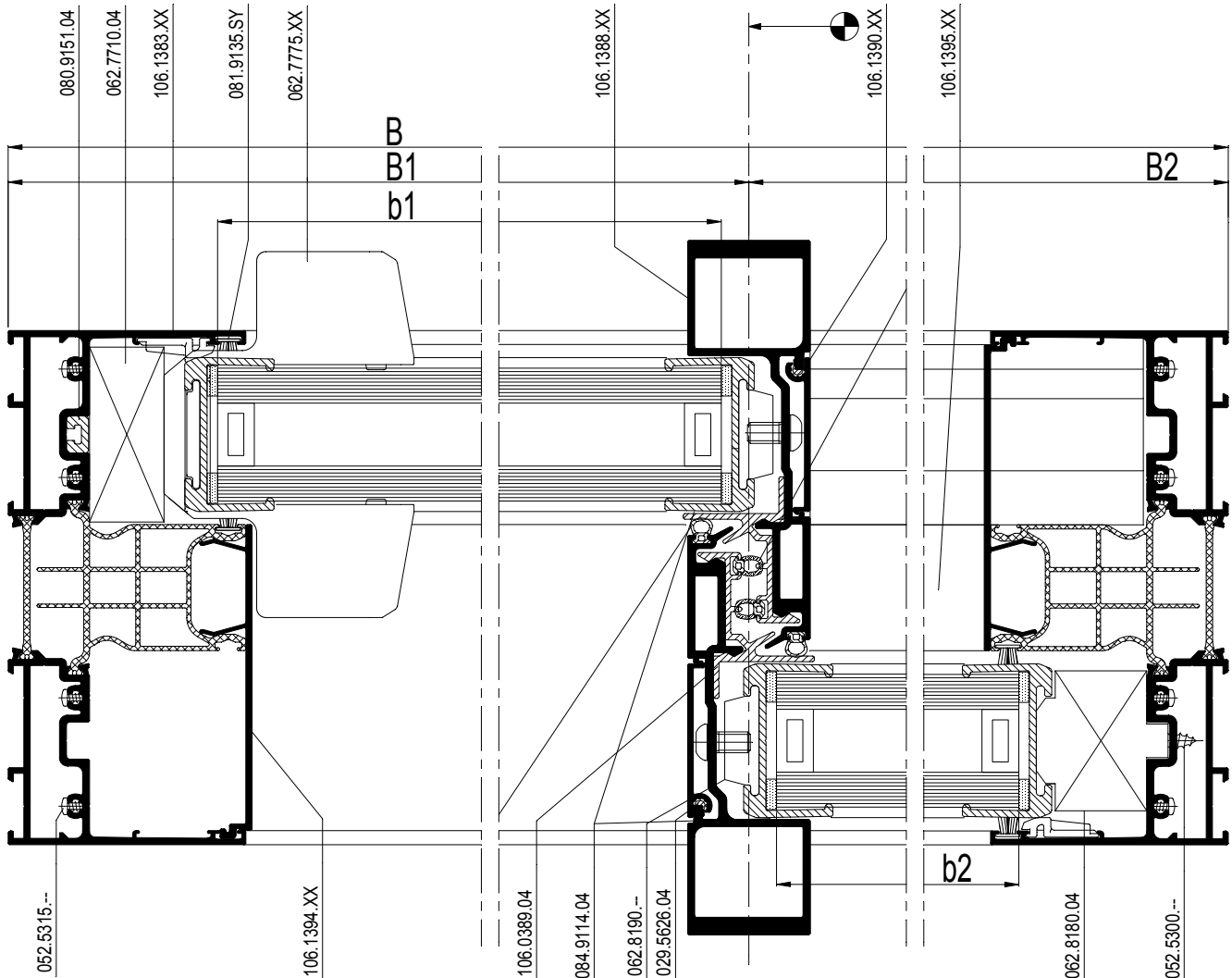

schaal - échelle  
 scale - Maßstab  
 1/2  
 D0092903



		#	
052.5321.--		16	25D.G. ...
069.6831.XX		25.F ...	25D.G. ...
069.6830.04		25.F ...	25D.G. ...
062.7710.04		2	25D.G. ...
052.5300.--		4	25D.G. ...
062.7775.XX		2	25D.G. ...
062.8180.04		25.F ...	25D.G. ...
052.5300.--		25.F ...	25D.G. ...
062.8182.--		1	25D.G. ...
052.5300.--		4	25D.G. ...
062.8226.--		1	25D.G. ...
052.5300.--		4	25D.G. ...
081.9135.SY		4x (B+H)	25D.G. ...
062.7823.--		2	25D.G. ...
062.8081.04		2	25D.G. ...
062.8176.04		1	25D.G. ...
062.8190.--		2x (H/500mm)	25D.G. ...
062.9309.04		4	25D.G. ...
062.9310.04		25.F ...	25D.G. ...
029.5626.04		2 x H	25D.G. ...
080.9150.04		H	25D.G. ...
080.9151.04		(2 x B) + H	25D.G. ...
080.8442.04		2 x H	25D.G. ...
080.9454.04		2 x H	25D.G. ...
062.8046.04		13.F ...	25D.G. ...
084.9114.04		2 X H	25D.G. ...
062.8160.XX		2	25D.G. ...
062.8161.XX		2	25D.G. ...
0L3.5353.00		25D.F. ...	25D.F. ...

## B - B

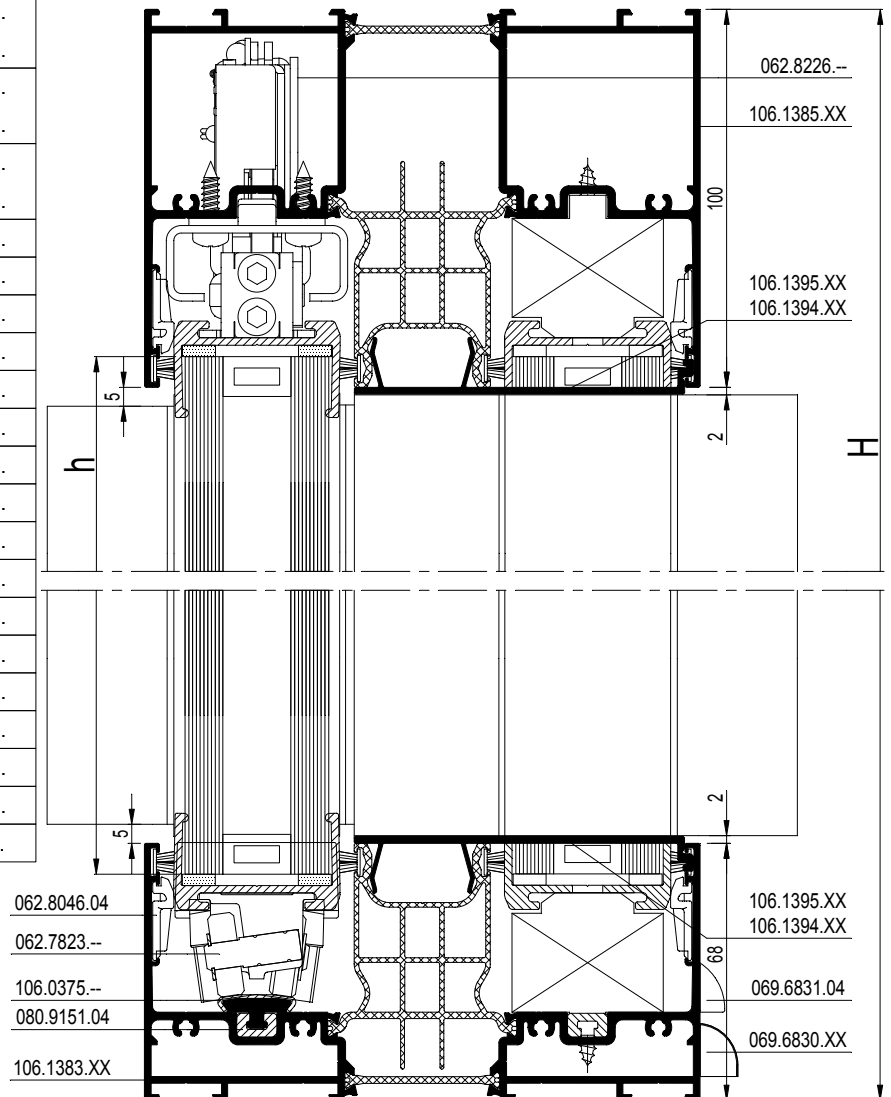

b1 = B1 - 68
b2 = B2 - 68
h = H - 152

schaal - échelle  
scale - Maßstab  
1/2



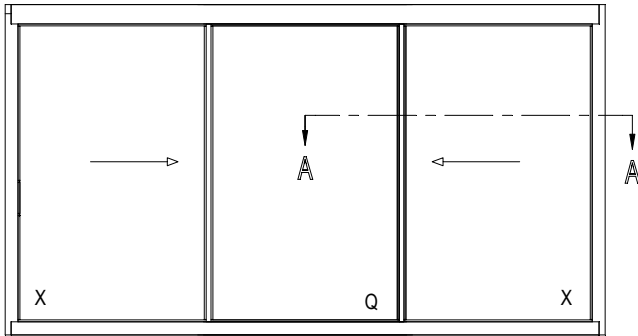



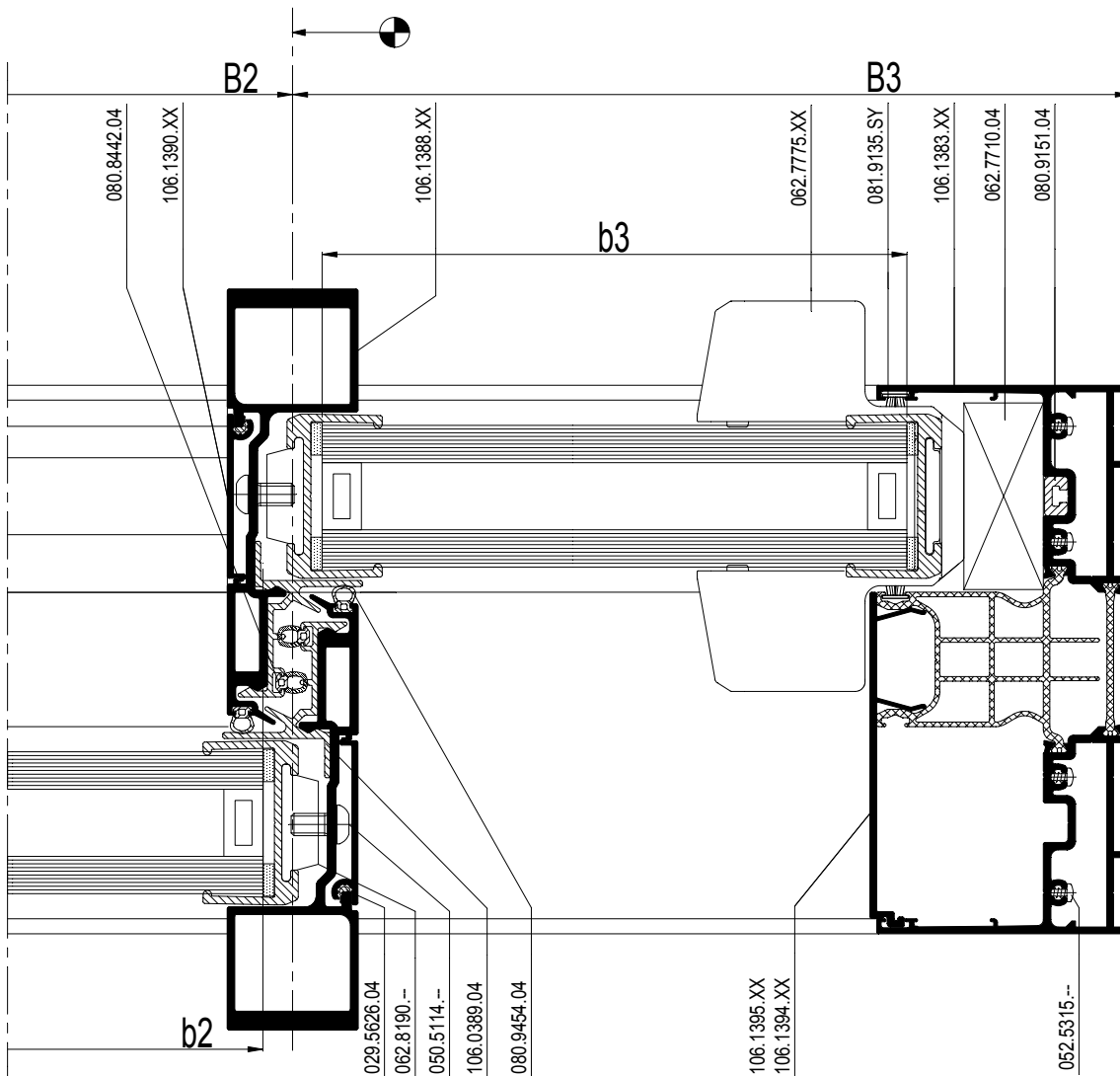























D00092903



			#	← Lm →	
106.1383.XX			2	H - 32	25D.C. ...
106.1385.XX			1	B - 49	
106.1394.XX			2	B1 - 85	25D.C. ...
			2	B3 - 85	25D.C. ...
			2	H - 168	25D.C. ...
106.1395.XX			2	B2 - 30	25D.C. ...
106.0389.04			2	H - 172	25D.C. ...
106.1388.XX			2	H - 172	25D.C. ...
106.1390.XX			2	H - 172	25D.C. ...
106.0375.--			1	B - 48	25D.C. ...



schaal - échelle  
 scale - Maßstab  
 1/2  
 D0093389

		#	
052.5321.--		16	25D.G. ...
069.6831.XX		25.F ...	25D.G. ...
069.6830.XX		25.F ...	25D.G. ...
062.7710.04		4	25D.G. ...
052.5300.--		8	25D.G. ...
062.7775.XX		4	25D.G. ...
062.8180.04		25.F ...	25D.G. ...
052.5300.--		25.F ...	25D.G. ...
062.8182.--		2	25D.G. ...
052.5300.--		8	25D.G. ...
062.8226.--		2	25D.G. ...
052.5300.--		8	25D.G. ...
081.9135.SY		4 x (B+H)	25D.G. ...
062.7823.--		4	25D.G. ...
062.8081.04		4	25D.G. ...
062.8176.04		2	25D.G. ...
062.8190.--		4 x (H/500mm)	25D.G. ...
062.9309.04		4	25D.G. ...
062.9310.04		25.F ...	25D.G. ...
029.5626.04		4 x H	25D.G. ...
080.9150.04		2 x H	25D.G. ...
080.9151.04		(2 x B) + (2 x H)	25D.G. ...
080.8442.04		4 x H	25D.G. ...
080.9454.04		4 x H	25D.G. ...
062.8046.04		13.F ...	25D.G. ...
084.9114.04		4 x H	25D.G. ...
062.8160.XX		4	25D.G. ...
0L3.5353.00		25D.F. ...	25D.F. ...

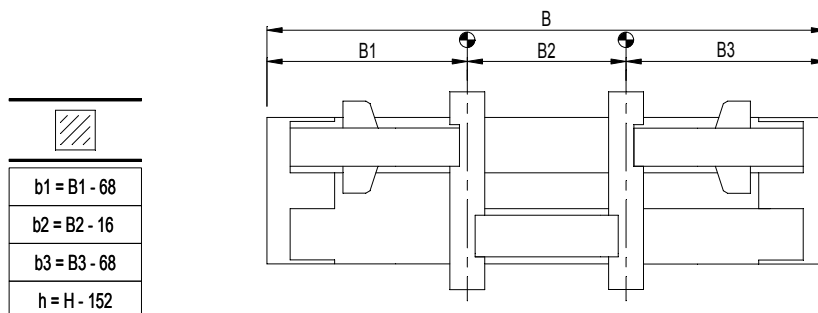

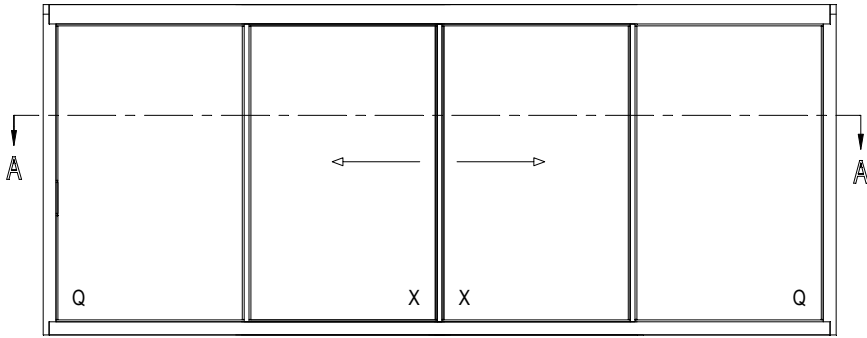

## A - A

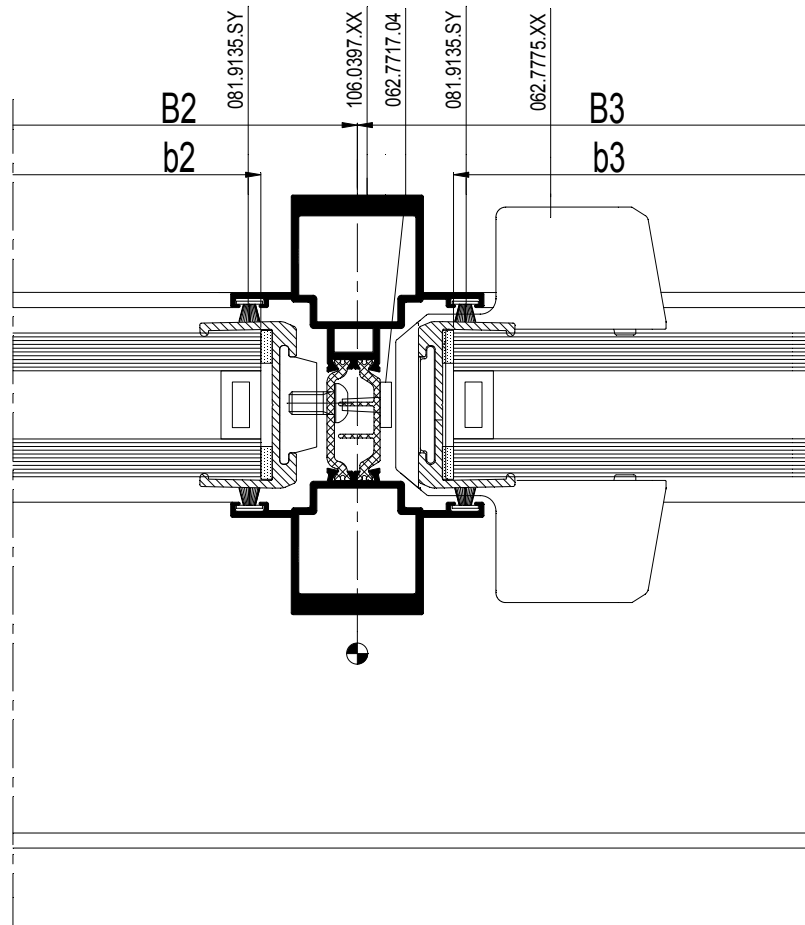

			#	$L_m$	
106.1383.XX			2	H - 32	25D.C. ...
			1	B - 49	
106.1385.XX			1	B - 49	25D.C. ...
106.1394.XX			2	(B2 + B3) - 30	25D.C. ...
			2	H - 79	
106.1395.XX			2	B1 - 85	25D.C. ...
			2	B4 - 85	
106.0389.XX			2	H - 172	25D.C. ...
			2	H - 178	
106.1388.XX			2	H - 172	25D.C. ...
			2	H - 178	
106.1390.XX			2	H - 172	25D.C. ...
			2	H - 114	
106.0375.--			1	B - 48	25D.C. ...
106.0397.XX			1	H - 114	25D.C. ...

		#	
052.5321.--		16	25D.G. ...
069.6830.04		25.F ...	25D.G. ...
069.6831.XX		25.F ...	25D.G. ...
062.7717.04		2	25D.G. ...
062.7775.XX		2	25D.G. ...
062.8180.04		25.F ...	25D.G. ...
052.5300.--		4	25D.G. ...
062.8182.--		2	25D.G. ...
052.5300.--		8	25D.G. ...
062.8226.--		2	25D.G. ...
052.5300.--		8	25D.G. ...
081.9135.SY		(4 x B) + (8 x H)	25D.G. ...
062.7823.--		4	25D.G. ...
062.8081.04		4	25D.G. ...
062.8176.04		1	25D.G. ...
062.8190.--		5 x (H/500mm)	25D.G. ...
062.9309.04		4	25D.G. ...
062.9310.04		25.F ...	25D.G. ...
029.5626.04		2 x H	25D.G. ...
080.9150.04		H	25D.G. ...
080.9151.04		2 x B	25D.G. ...
080.8442.04		4 x H	25D.G. ...
080.9454.04		4 x H	25D.G. ...
062.8046.04		13.F ...	25D.G. ...
084.9114.04		4 x H	25D.G. ...
062.8160.XX		4	25D.G. ...
062.8161.XX		4	25D.G. ...
0L3.5353.00		25D.F. ...	25D.F. ...
067.5216.--		1 x (H/500MM)	25D.G. ...

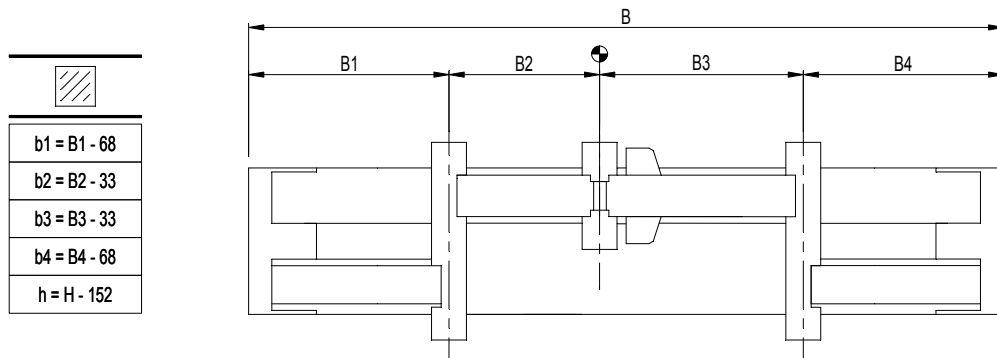

schaal - échelle  
 scale - Maßstab  
 1/2

D0093393

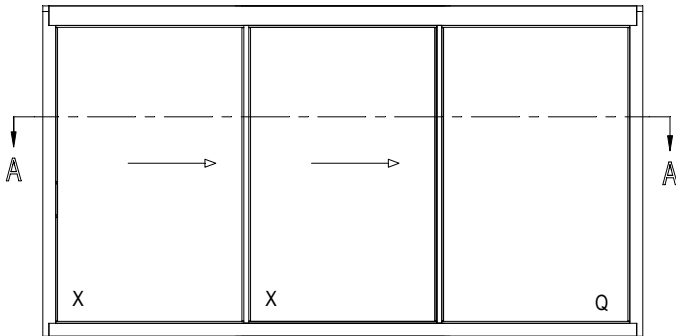

## A - A

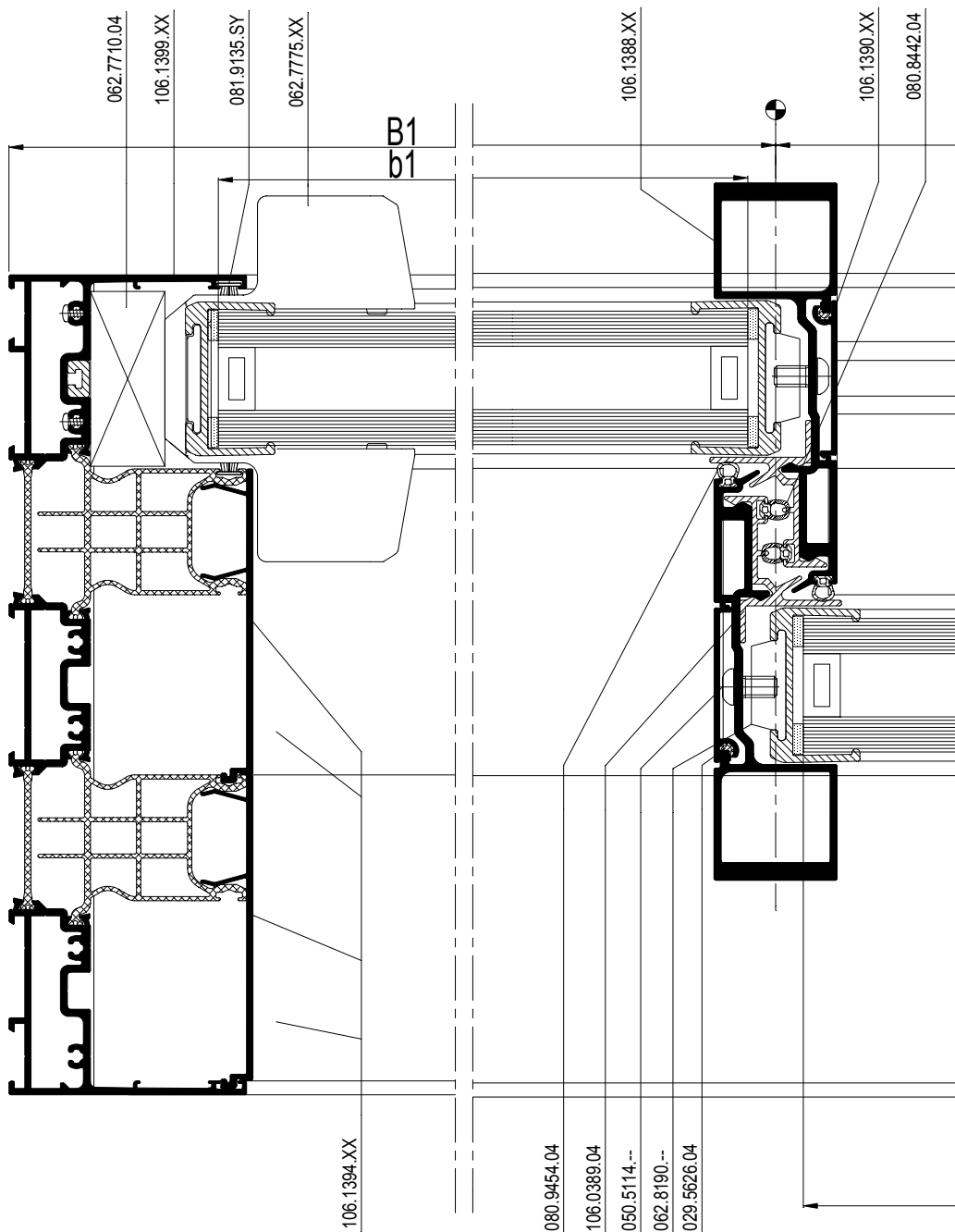

schaal - échelle  
 scale - Maßstab  
 1/2  
 D0095186



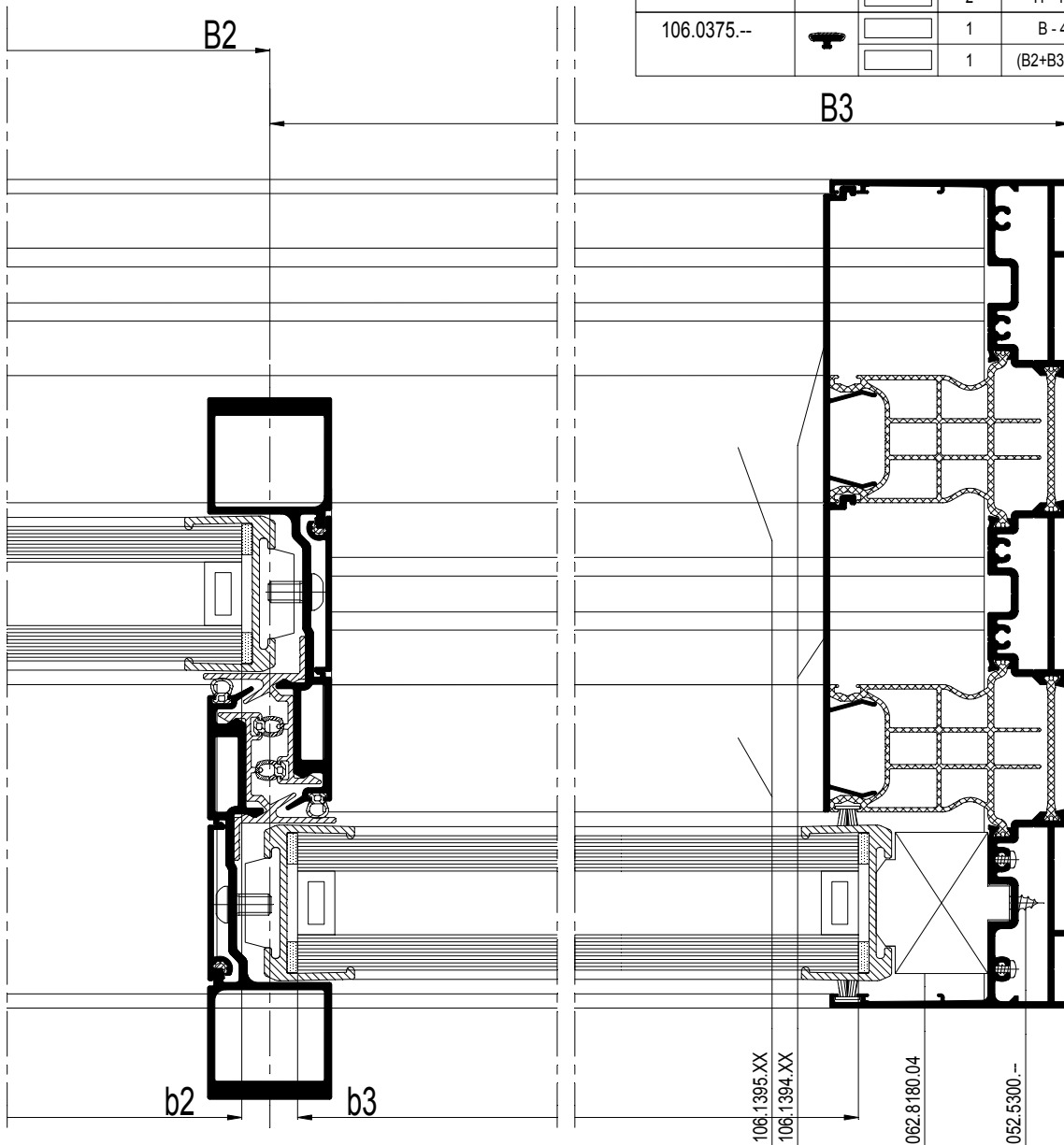





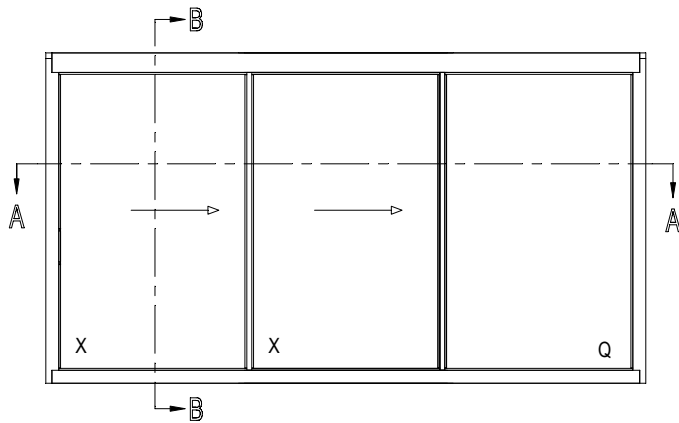























			#	Ln	
106.1399.XX			2	H - 32	25D.C. ...
			1	B - 49	
106.1400.XX			1	B - 49	25D.C. ...
106.1394.XX			2	B1 - 85	25D.C. ...
			2	(B1 + B2) - 85	25D.C. ...
			2	H - 79	25D.C. ...
			2	H - 168	25D.C. ...
106.1395.XX			2	(B2 + B3) - 85	25D.C. ...
			2	B3 - 85	
106.0389.XX			1	H - 172	25D.C. ...
			3	H - 178	25D.C. ...
106.1388.XX			1	H - 172	25D.C. ...
			3	H - 178	
106.1390.XX			2	H - 172	25D.C. ...
			2	H - 114	
106.0375.--			1	B - 48	25D.C. ...
			1	(B2+B3) - 24	



schaal - échelle  
 scale - Maßstab  
 1/2

D0095186



		#	
052.5321.--		16	25D.G. ...
069.6831.XX		25.F ...	25D.G. ...
069.6830.04		25.F ...	25D.G. ...
062.7710.04		2	25D.G. ...
052.5300.--		4	25D.G. ...
062.7775.XX		2	25D.G. ...
062.8180.04		25.F ...	25D.G. ...
052.5300.--		4	25D.G. ...
062.8182.--		2	25D.G. ...
052.5300.--		8	25D.G. ...
062.8226.--		1	25D.G. ...
052.5300.--		4	25D.G. ...
081.9135.SY		4 x (B+H)	25D.G. ...
062.7823.--		4	25D.G. ...
062.8081.04		4	25D.G. ...
062.8176.04		1	25D.G. ...
062.8190.--		4 x (H/500mm)	25D.G. ...
062.9309.04		4	25D.G. ...
062.9310.04		25.F ...	25D.G. ...
029.5626.04		4 x H	25D.G. ...
080.9150.04		1 x H	25D.G. ...
080.9151.04		(3 x B) + H	25D.G. ...
080.8442.04		4 x H	25D.G. ...
080.9454.04		4 x H	25D.G. ...
062.8046.04		13.F ...	25D.G. ...
084.9114.04		4 x H	25D.G. ...
062.8160.XX		6	25D.G. ...
062.8161.XX		2	25D.G. ...
0L3.5353.00		25D.F. ...	25D.F. ...



## B - B

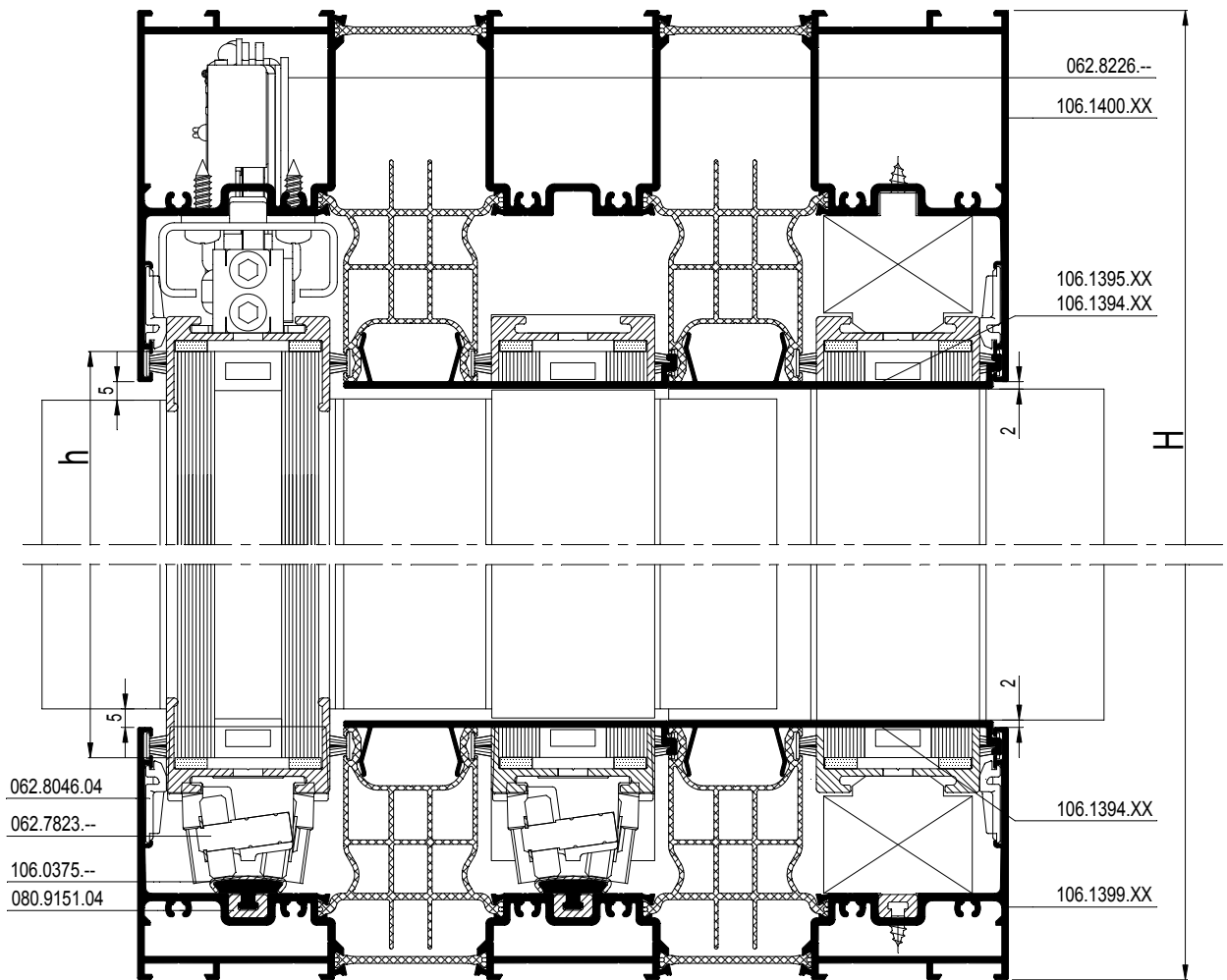

b1 = B1 - 68
b2 = B2 - 16
b3 = B3 - 68
h = H - 152

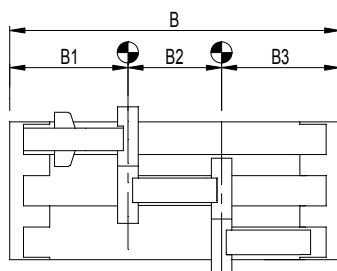

schaal - échelle  
 scale - Maßstab  
 1/2

D009526

2-RAIL  
2-RAIL

2-RAIL  
2-RAIL

Fg max (X) ≤ 500 KG  
B (X) ≤ B (Q)

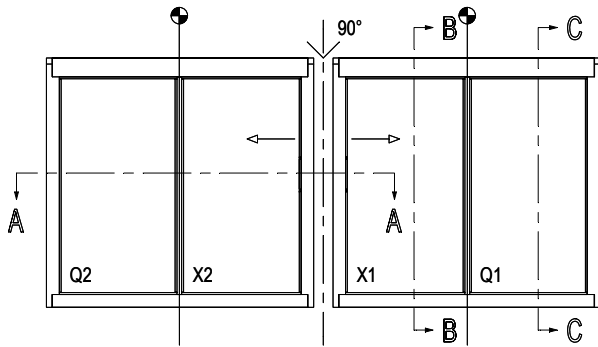

Inside Corner

Outside Corner

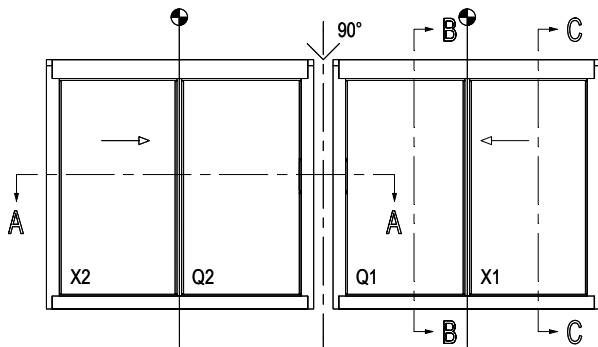
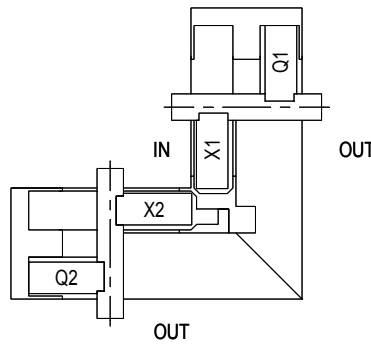
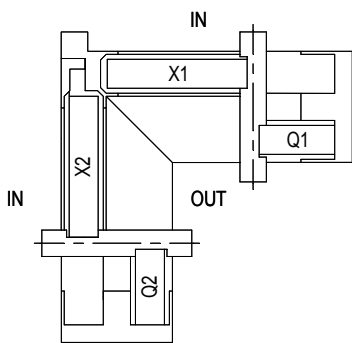

Inside Corner

Outside Corner

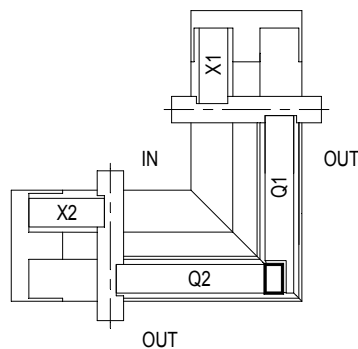
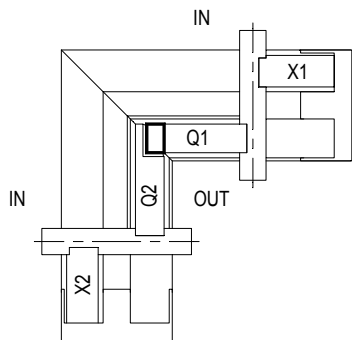

2-RAIL  
2-RAIL

2-RAIL  
2-RAIL

Fg max (X) ≤ 300 KG  
B (X) ≤ B (Q)

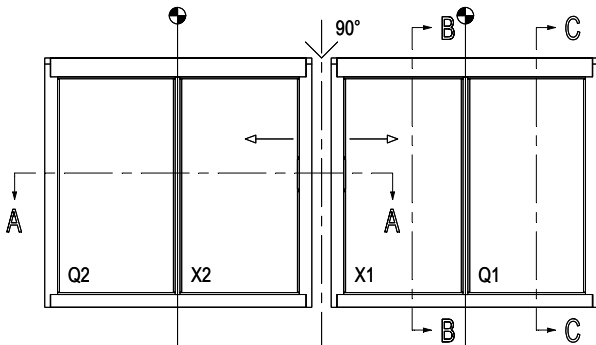

Inside Corner

Outside Corner

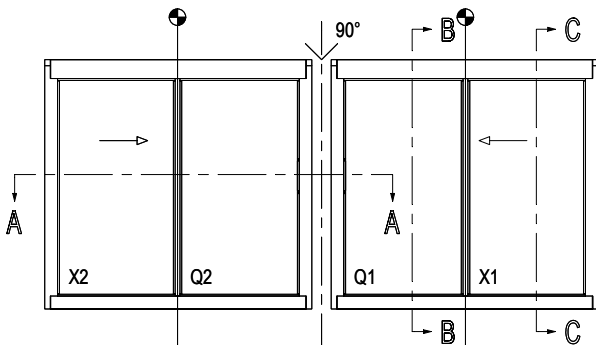
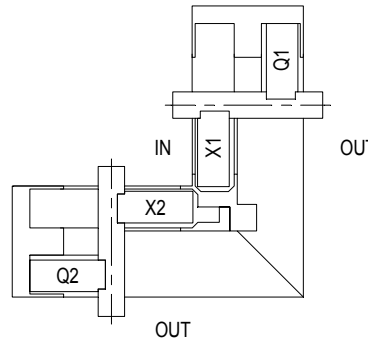
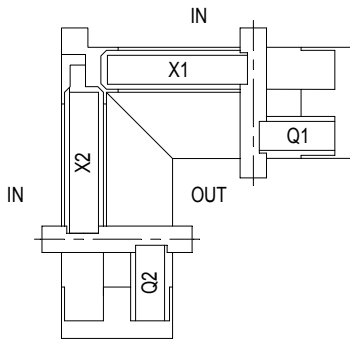

Inside Corner

Outside Corner

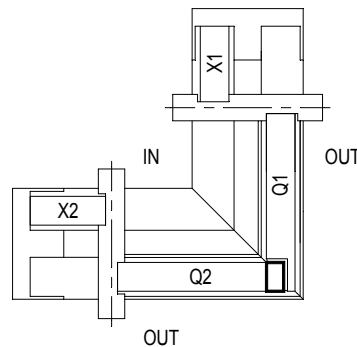
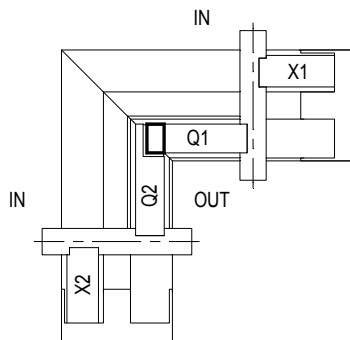

schaal - échelle  
scale - Maßstab  
1/2

D2000451

### METHOD 1

$h = H - 152$
$bx1 = BX1 - 162.5$
$bq1 = BQ1 - 68$
$bx2 = BX2 - 162.5$
$bq2 = BQ2 - 68$

AS SHOWN ON ALL  
E-PAGES

			#	$L_m$	
106.1383.XX			2	H - 32	25D.C. ...
			1	B1 - 25	
			1	B2 - 25	
106.1385.XX			1	B1 - 25	25D.C. ...
			1	B2 - 25	
106.1394.XX			2	BX1 - 15	25D.C. ...
			2	BX2 - 15	
			2	H - 79	
106.1395.XX			2	BQ1-85	25D.C. ...
			2	BQ2-85	
106.0389.04			2	H - 172	25D.C. ...
106.1388.XX			2	H - 172	25D.C. ...
			2	H - 178	
106.1390.XX			2	H - 172	25D.C. ...
			2	H - 114	
106.0360.XX			1	H - 114	25D.C. ...
106.0361.XX			1	H - 114	25D.C. ...

		#	
062.9310.04		2	25D.G. ...
062.8087.--		2	25D.G. ...
062.8088.--		2	25D.G. ...
062.9425.--		4	25D.G. ...
062.9426.--		4	25D.G. ...
062.9427.--		2	25D.G. ...

### METHOD 2

$h = H - 152$
$bx1 = BX1 - 162.5$
$bq1 = BQ1 - 68$
$bx2 = BX2 - 162.5$
$bq2 = BQ2 - 68$

			#	$L_m$	
106.1383.XX			2	H	25D.C. ...
			1	B1 - 25	
			1	B2 - 25	
106.1385.XX			1	B1 - 25	25D.C. ...
			1	B2 - 25	
106.1394.XX			2	BX1 - 15	25D.C. ...
			2	BX2 - 15	
			2	H - 79	
106.1395.XX			2	BQ1-85	25D.C. ...
			2	BQ2-85	
106.0389.04			2	H - 172	25D.C. ...
106.1388.XX			2	H - 172	25D.C. ...
			2	H - 178	
106.1390.XX			2	H - 172	25D.C. ...
			2	H - 114	
106.0360.XX			1	H - 114	25D.C. ...
106.0361.XX			1	H - 114	25D.C. ...

		#	
062.9310.04		0	25D.G. ...
062.8087.--		2	25D.G. ...
062.8088.--		2	25D.G. ...
062.9425.--		4	25D.G. ...
062.9426.--		4	25D.G. ...
062.9427.--		2	25D.G. ...

schaal - échelle  
 scale - Maßstab  
 1/2

			#	$\leftarrow L_m \rightarrow$	
106.1383.XX			2	H - 64	25D.C. ...
106.1385.XX			2	B1 - 25 B2 - 25	25D.C. ...
106.1394.XX			2	BX1 - 15 BX2 - 15	25D.C. ...
106.1395.XX			2	H - 111	25D.C. ...
106.0389.04			2	BQ1-85 BQ2-85	25D.C. ...
106.1388.XX			2	H - 204	25D.C. ...
106.1390.XX			2	H - 210	25D.C. ...
106.1390.XX			2	H - 150	25D.C. ...
106.0360.XX			1	H - 150	25D.C. ...
106.0361.XX			1	H - 150	25D.C. ...

METHOD 1  
300 Pa

$h = H - 184$
$bx1 = BX1 - 162.5$
$bq1 = BQ1 - 68$
$bx2 = BX2 - 162.5$
$bq2 = BQ2 - 68$

		#	
062.9310.04		4	25D.G. ...
062.8087.--		0	25D.G. ...
062.8088.--		4	25D.G. ...
062.9425.--		0	25D.G. ...
062.9426.--		8	25D.G. ...
062.9427.--		4	25D.G. ...

			#	$\leftarrow L_m \rightarrow$	
106.1383.XX			2	H	25D.C. ...
106.1385.XX			2	B1 - 25 B2 - 25	25D.C. ...
106.1394.XX			2	BX1 - 15 BX2 - 15	25D.C. ...
106.1395.XX			2	H - 111	25D.C. ...
106.0389.04			2	BQ1-85 BQ2-85	25D.C. ...
106.0389.04			2	H - 204	25D.C. ...
106.1388.XX			2	H - 210	25D.C. ...
106.1388.XX			2	H - 204	25D.C. ...
106.1390.XX			2	H - 210	25D.C. ...
106.1390.XX			2	H - 146	25D.C. ...
106.0360.XX			1	H - 146	25D.C. ...
106.0361.XX			1	H - 146	25D.C. ...

METHOD 2  
300 Pa

$h = H - 184$
$bx1 = BX1 - 162.5$
$bq1 = BQ1 - 68$
$bx2 = BX2 - 162.5$
$bq2 = BQ2 - 68$

		#	
062.9310.04		0	25D.G. ...
062.8087.--		0	25D.G. ...
062.8088.--		4	25D.G. ...
062.9425.--		0	25D.G. ...
062.9426.--		8	25D.G. ...
062.9427.--		4	25D.G. ...

schaal - échelle  
 scale - Maßstab  
 1/2

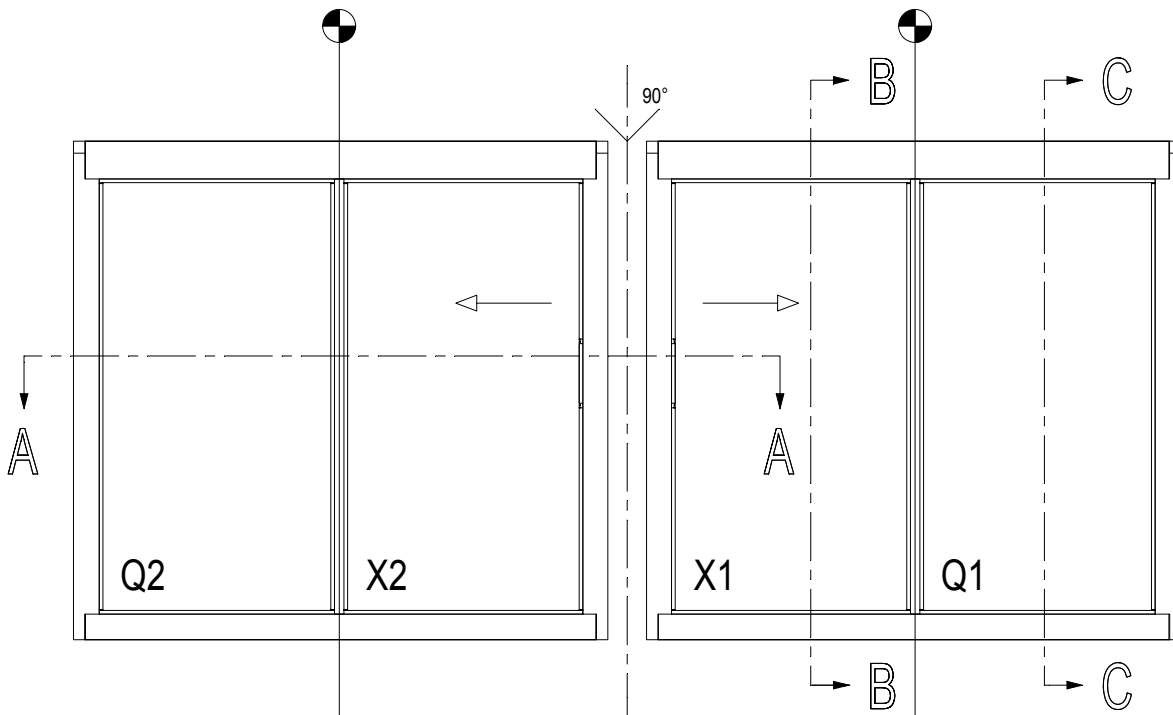

			#	$\leftarrow L_m \rightarrow$	
106.1383.XX			2	H - 32	25D.C. ...
			1	B1 - 25	
			1	B2 - 25	
106.1385.XX			1	B1 - 25	25D.C. ...
			1	B2 - 25	
106.1394.XX			2	H - 79	25D.C. ...
			2	BX1 - 15	
			2	BX2 - 15	
106.1395.XX			2	BQ1 - 85	25D.C. ...
			2	BQ2 - 85	
106.0389.04			2	H - 172	25D.C. ...
			2	H - 178	
106.1388.XX			2	H - 172	25D.C. ...
			2	H - 178	
106.1390.XX			2	H - 172	25D.C. ...
			2	H - 114	
106.0375.--			1	B1 - 131	25D.C. ...
			1	B2 - 131	
106.0360.XX			1	H - 114	25D.C. ...
106.0361.XX			1	H - 114	25D.C. ...

## Outside Corner

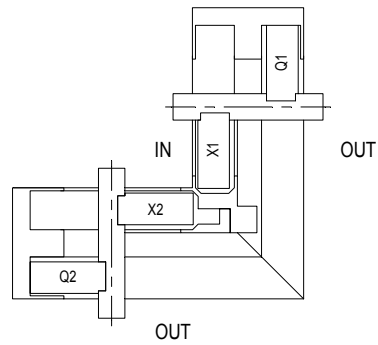

bx1 = BX1 - 162,5
bq1 = BQ1 - 68
bx2 = BX2 - 162,5
bq2 = BQ2 - 68
h = H - 152

A - A

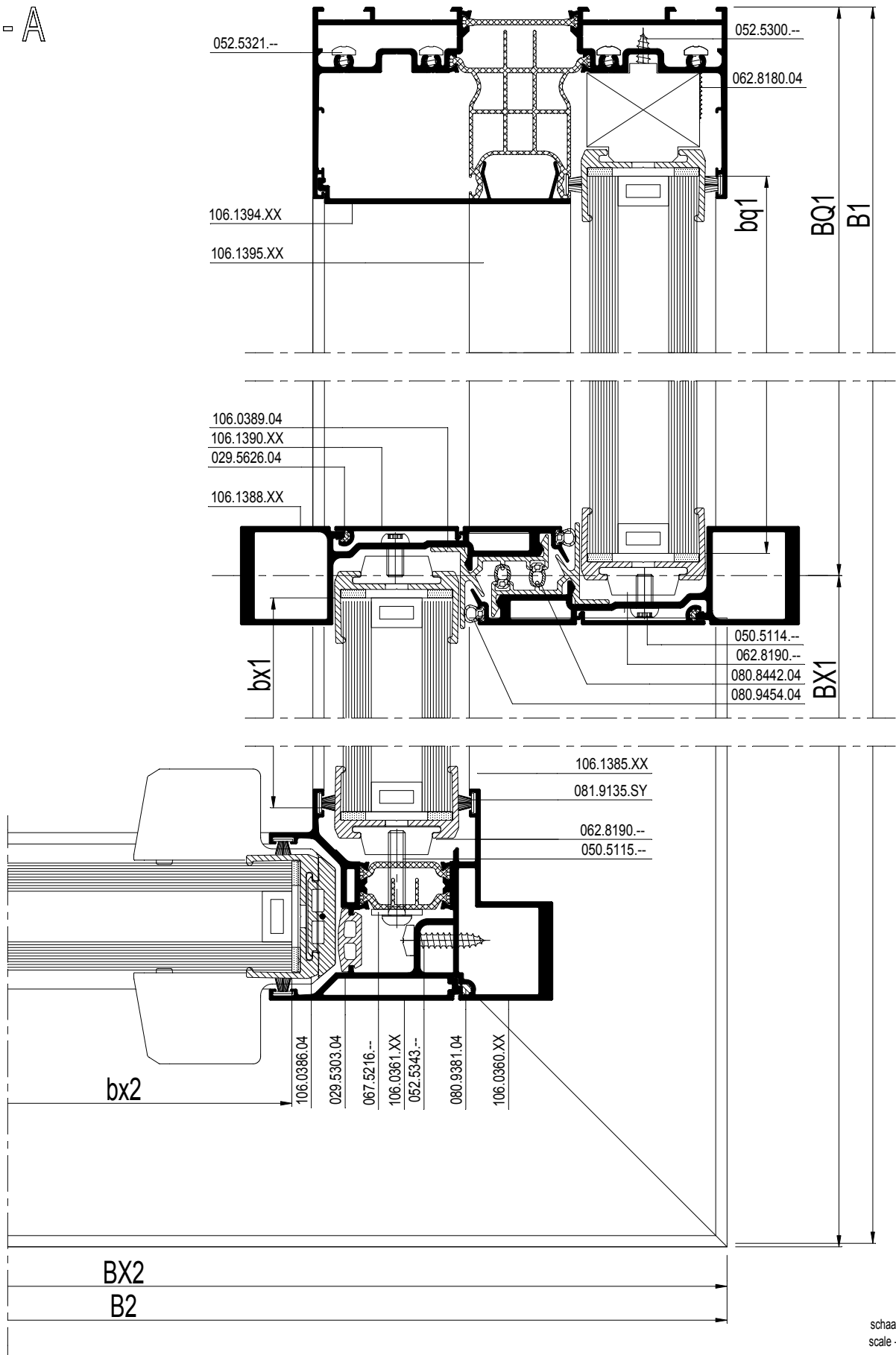

schaal - échelle  
 scale - Maßstab  
 1/2

D2000454

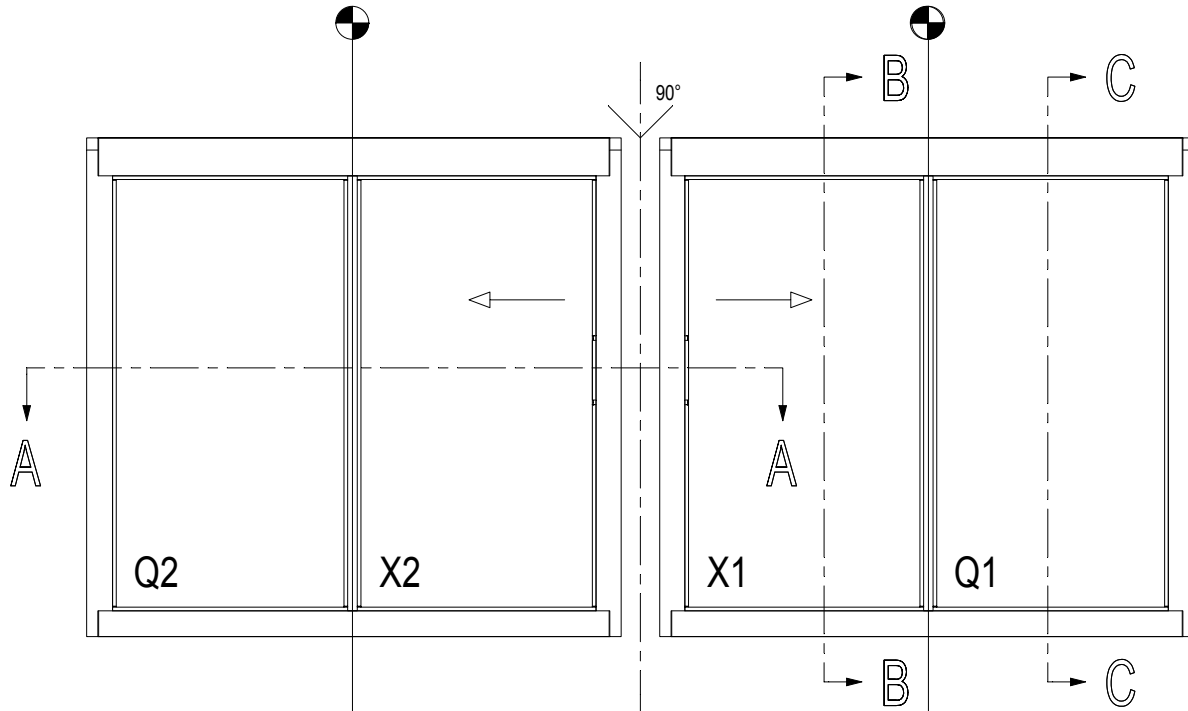

B - B

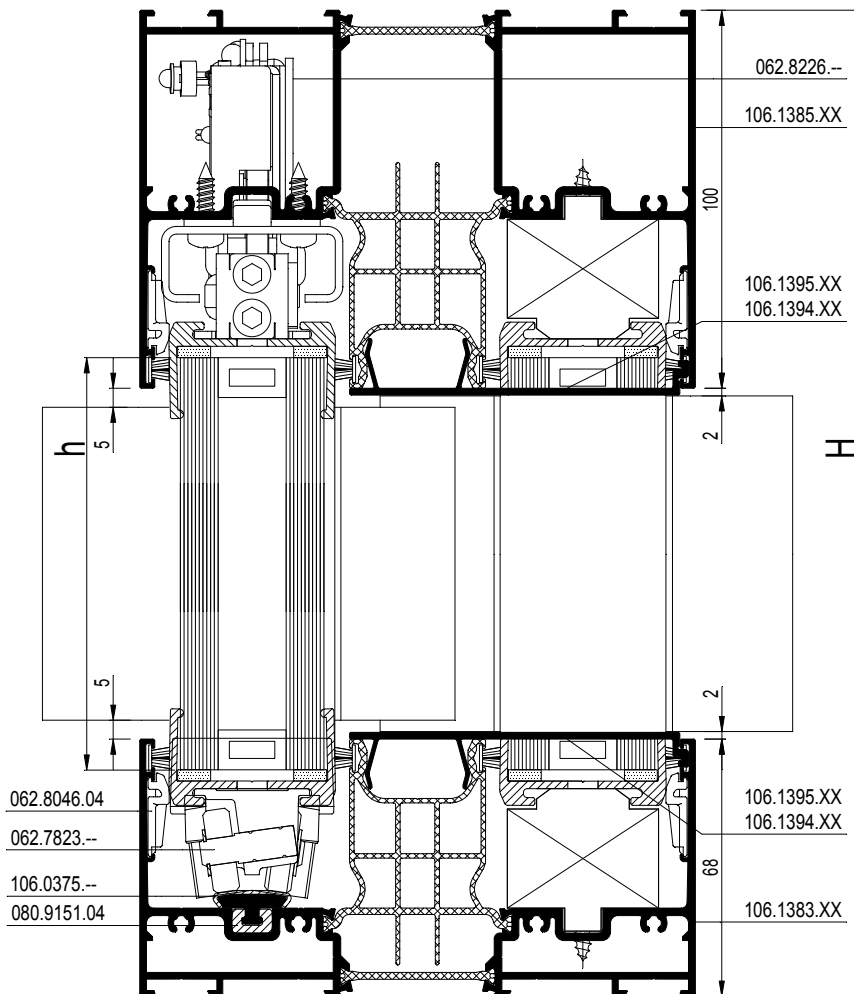

schaal - échelle  
 scale - Maßstab  
 1/2  
 D20000518



		#	
062.7775.--		2	25D.G. ...
062.8226.--		2	25D.G. ...
052.5300.--		8	25D.G. ...
080.9151.04		4 x ( B1 + B2 )	25D.G. ...
081.9135.SY		8 x ( B1 + B2 + H )	25D.G. ...
080.8442.04		4 x H	25D.G. ...
080.9454.04		4 x H	25D.G. ...
062.8190.--		5 x (H/500mm)	25D.G. ...
029.5626.04		4 x H	25D.G. ...
080.9381.04		H	25D.G. ...
062.8180.04		25.F ...	25D.G. ...
052.5300.--		25.F ...	25D.G. ...
062.7823.--		4	25D.G. ...
062.9310.04		25.F ...	25D.G. ...
062.9309.04		4	25D.G. ...
052.5321.--		16	ACCESS CS
062.8046.04		25.F ...	25D.G. ...
062.8176.04		1	25D.G. ...
062.8182.--		2	25D.G. ...
052.5300.--		8	25D.G. ...
062.8081.04		4	25D.G. ...
080.9150.04		H	25D.G. ...
050.5115.--		1 x (H/500mm)	25D.G. ...
067.5216.--		1 x (H/500mm)	25D.G. ...
052.5343.--		1 x (H/300mm)	25D.G. ...
029.5303.04		H	25D.G. ...
062.8087.--		2	25D.G. ...
062.8088.--		2	25D.G. ...
062.9425.--		4	25D.G. ...
062.9426.--		4	25D.G. ...
062.9427.--		2	25D.G. ...
054.5441.04		32	25D.G. ...
050.5094.--		32	25D.G. ...
069.6830.XX		min. 4	25D.G. ...
069.6831.XX		25.F ...	25D.G. ...
084.9114.04		5 x H	25D.G. ...
062.8160.XX		4	25D.G. ...
050.5050.--		4	25D.G. ...
062.8161.XX		4	25D.G. ...
052.5333.--		8	25D.G. ...

## Outside Corner

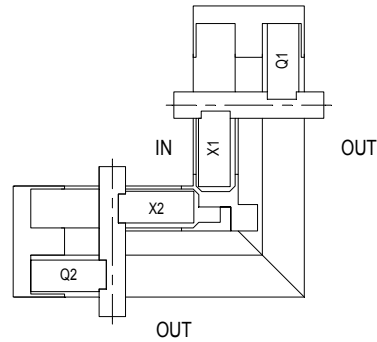

bx1 = BX1 - 162.5
bq1 = BQ1 - 68
bx2 = BX2 - 162.5
bq2 = BQ2 - 68
h = H - 152

## Inside Corner

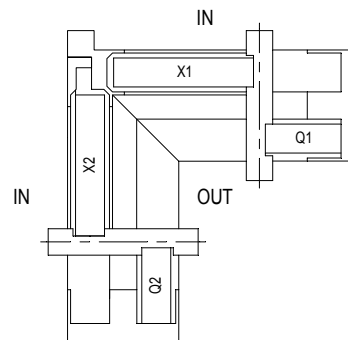

bx1 = BX1 - 75
bq1 = BQ1 - 68
bx2 = BX2 - 75
bq2 = BQ2 - 68
h = H - 152

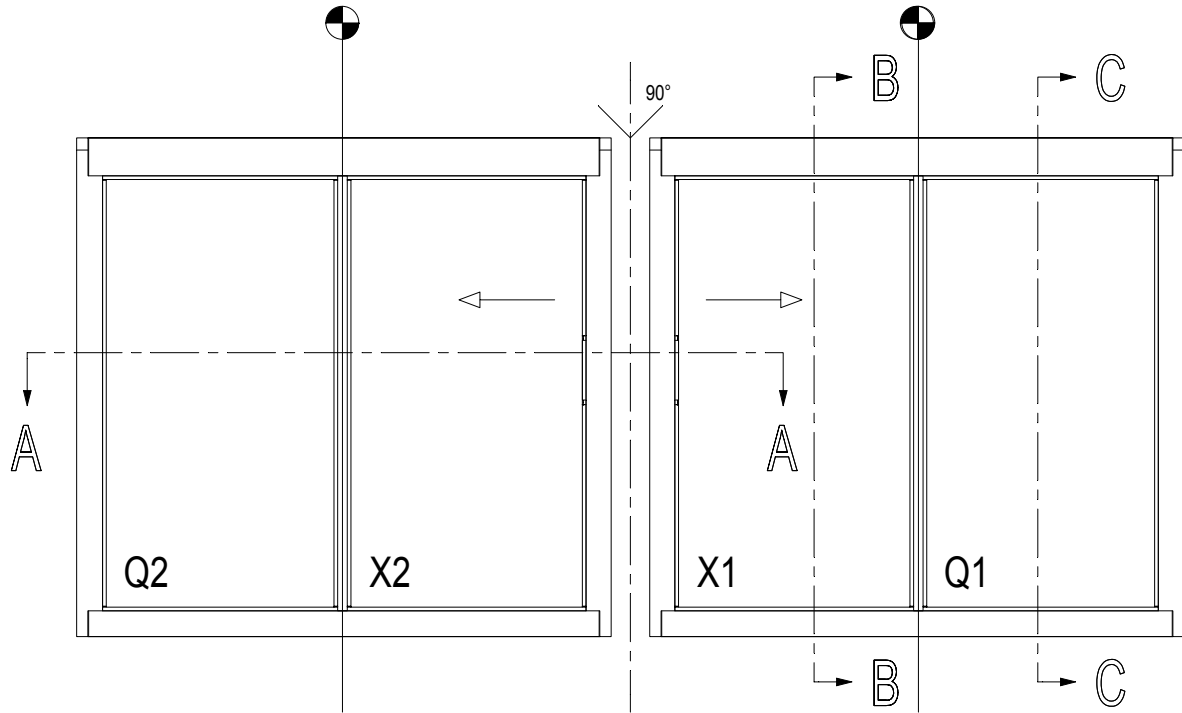

C - C

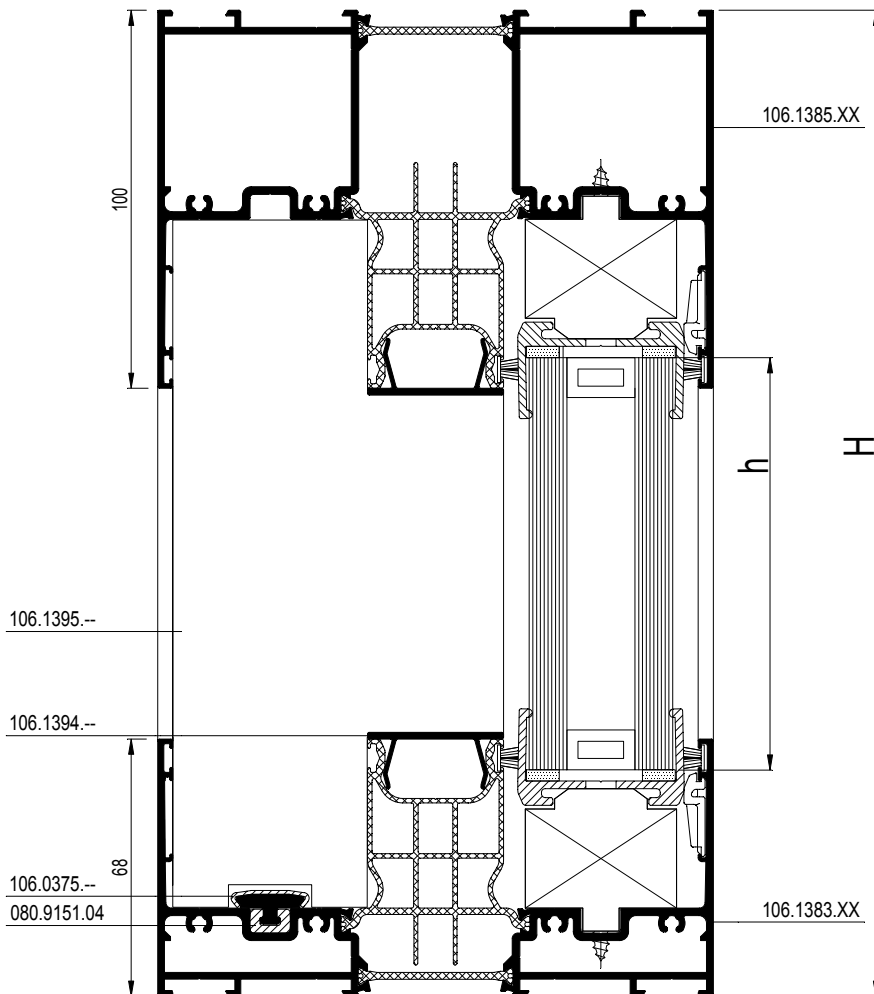

schaal - échelle  
 scale - Maßstab  
 1/2  
 D20000519

## Outside Corner

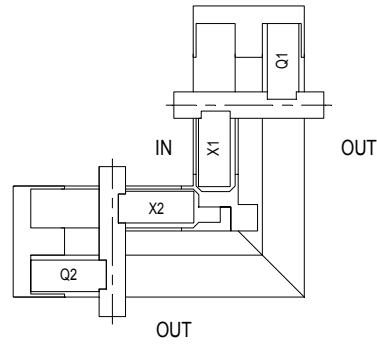

$bx1 = BX1 - 162.5$
$bq1 = BQ1 - 68$
$bx2 = BX2 - 162.5$
$bq2 = BQ2 - 68$
$h = H - 152$

## Inside Corner

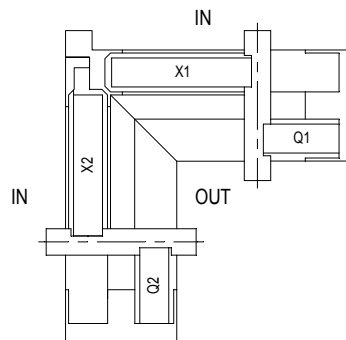

$bx1 = BX1 - 75$
$bq1 = BQ1 - 68$
$bx2 = BX2 - 75$
$bq2 = BQ2 - 68$
$h = H - 152$

## METHOD 1

h = H - 152
bx1 = BX1 - 75
bq1 = BQ1 - 68
bx2 = BX2 - 75
bq2 = BQ2 - 68

			#	Lm	
106.1383.XX			2	H - 32	25D.C. ...
			1	B1 - 25	
			1	B2 - 25	
106.1385.XX			1	B1 - 25	25D.C. ...
			1	B2 - 25	
106.1394.XX			2	BX1 - 70	25D.C. ...
			2	BX2 - 70	
			2	H - 79	
106.1395.XX			2	BQ1-85	25D.C. ...
			2	BQ2-85	
106.0389.04			2	H - 172	25D.C. ...
			2	H - 178	
106.1388.XX			2	H - 172	25D.C. ...
			2	H - 178	
106.1390.XX			2	H - 172	25D.C. ...
			2	H - 178	
106.0360.XX			1	H - 114	25D.C. ...
106.0361.XX			1	H - 114	25D.C. ...

		#	
062.9310.04		2	25D.G. ...
062.8087.--		2	25D.G. ...
062.8088.--		2	25D.G. ...
062.9425.--		4	25D.G. ...
062.9426.--		4	25D.G. ...
062.9427.--		2	25D.G. ...

## METHOD 2

h = H - 152
bx1 = BX1 - 75
bq1 = BQ1 - 68
bx2 = BX2 - 75
bq2 = BQ2 - 68

			#	Lm	
106.1383.XX			2	H	25D.C. ...
			1	B1 - 25	
			1	B2 - 25	
106.1385.XX			1	B1 - 25	25D.C. ...
			1	B2 - 25	
106.1394.XX			2	BX1 - 70	25D.C. ...
			2	BX2 - 70	
			2	H - 79	
106.1395.XX			2	BQ1-85	25D.C. ...
			2	BQ2-85	
106.0389.04			2	H - 172	25D.C. ...
			2	H - 178	
106.1388.XX			2	H - 172	25D.C. ...
			2	H - 178	
106.1390.XX			2	H - 172	25D.C. ...
			2	H - 178	
106.0360.XX			1	H - 114	25D.C. ...
106.0361.XX			1	H - 114	25D.C. ...

		#	
062.9310.04		0	25D.G. ...
062.8087.--		2	25D.G. ...
062.8088.--		2	25D.G. ...
062.9425.--		4	25D.G. ...
062.9426.--		4	25D.G. ...
062.9427.--		2	25D.G. ...

			#	$\leftarrow L_m \rightarrow$	
106.1383.XX			2	H - 64	25D.C. ...
106.1385.XX			2	B1 - 25 B2 - 25	25D.C. ...
106.1394.XX			2	BX1 - 70 BX2 - 70	25D.C. ...
106.1395.XX			2	H - 111	25D.C. ...
106.0389.04			2	BQ1-85 BQ2-85	25D.C. ...
106.1388.XX			2	H - 204	25D.C. ...
106.1390.XX			2	H - 210	25D.C. ...
106.1390.XX			2	H - 204 H - 146	25D.C. ...
106.0360.XX			1	H - 146	25D.C. ...
106.0361.XX			1	H - 146	25D.C. ...

METHOD 1  
300 Pa

h = H - 184
bx1 = BX1 - 75
bq1 = BQ1 - 68
bx2 = BX2 - 75
bq2 = BQ2 - 68

		#	
062.9310.04		4	25D.G. ...
062.8087.--		0	25D.G. ...
062.8088.--		4	25D.G. ...
062.9425.--		0	25D.G. ...
062.9426.--		8	25D.G. ...
062.9427.--		4	25D.G. ...

			#	$\leftarrow L_m \rightarrow$	
106.1383.XX			2	H	25D.C. ...
106.1385.XX			2	B1 - 25 B2 - 25	25D.C. ...
106.1394.XX			2	BX1 - 70 BX2 - 70	25D.C. ...
106.1395.XX			2	H - 111	25D.C. ...
106.0389.04			2	BQ1-85 BQ2-85	25D.C. ...
106.1388.XX			2	H - 204	25D.C. ...
106.1390.XX			2	H - 210	25D.C. ...
106.1390.XX			2	H - 204 H - 146	25D.C. ...
106.0360.XX			1	H - 146	25D.C. ...
106.0361.XX			1	H - 146	25D.C. ...

METHOD 2  
300 Pa

h = H - 184
bx1 = BX1 - 75
bq1 = BQ1 - 68
bx2 = BX2 - 75
bq2 = BQ2 - 68

		#	
062.9310.04		0	25D.G. ...
062.8087.--		0	25D.G. ...
062.8088.--		4	25D.G. ...
062.9425.--		0	25D.G. ...
062.9426.--		8	25D.G. ...
062.9427.--		4	25D.G. ...

schaal - échelle  
scale - Maßstab  
1/2

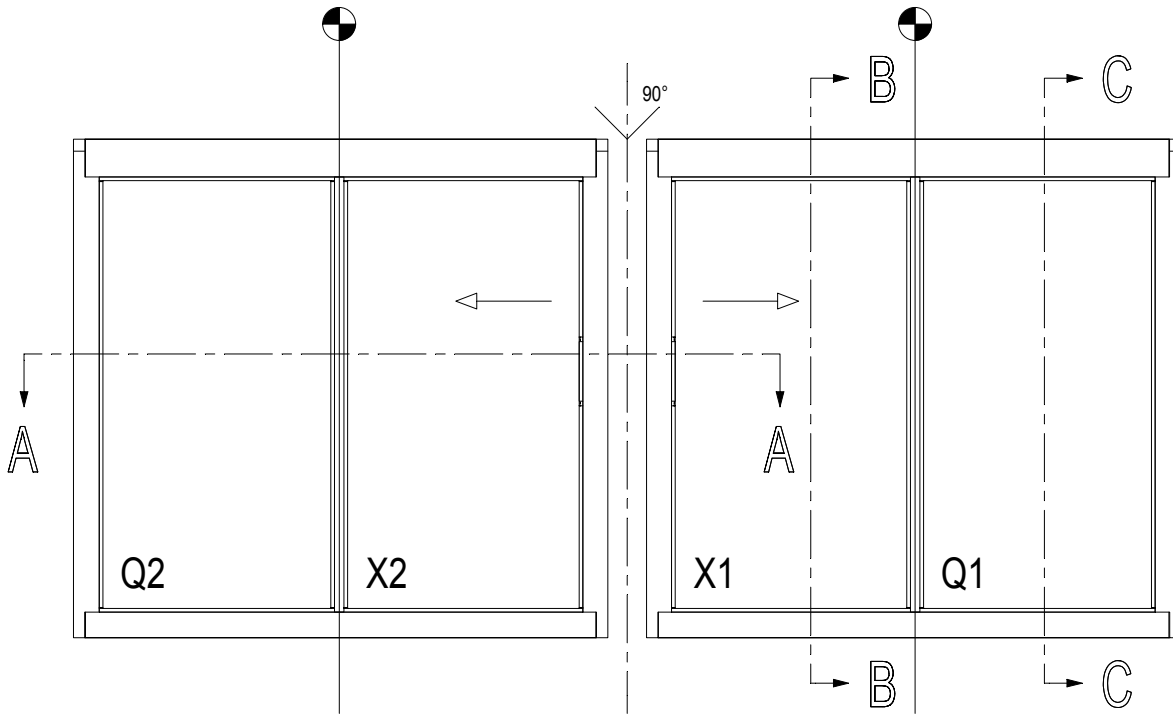

			#	$\leftarrow L_m \rightarrow$	
106.1383.XX			2	H - 32	25D.C. ...
			1	B1 - 25	
			1	B2 - 25	
106.1385.XX			1	B1 - 25	25D.C. ...
			1	B2 - 25	
106.1394.XX			2	H - 79	25D.C. ...
			2	BX1 - 70	
			2	BX2 - 70	
106.1395.XX			2	BQ1 - 85	25D.C. ...
			2	BQ2 - 85	
106.0389.04			2	H - 172	25D.C. ...
			2	H - 178	
106.1388.XX			2	H - 172	25D.C. ...
			2	H - 178	
106.1390.XX			2	H - 172	25D.C. ...
			2	H - 114	
106.0375.--			1	B1 - 43.5	25D.C. ...
			1	B2 - 43.5	
106.0360.XX			1	H - 114	25D.C. ...
106.0361.XX			1	H - 114	25D.C. ...

### Inside Corner

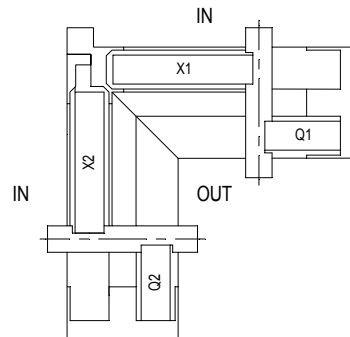

bx1 = BX1 - 75
bq1 = BQ1 - 68
bx2 = BX2 - 75
bq2 = BQ2 - 68
h = H - 152

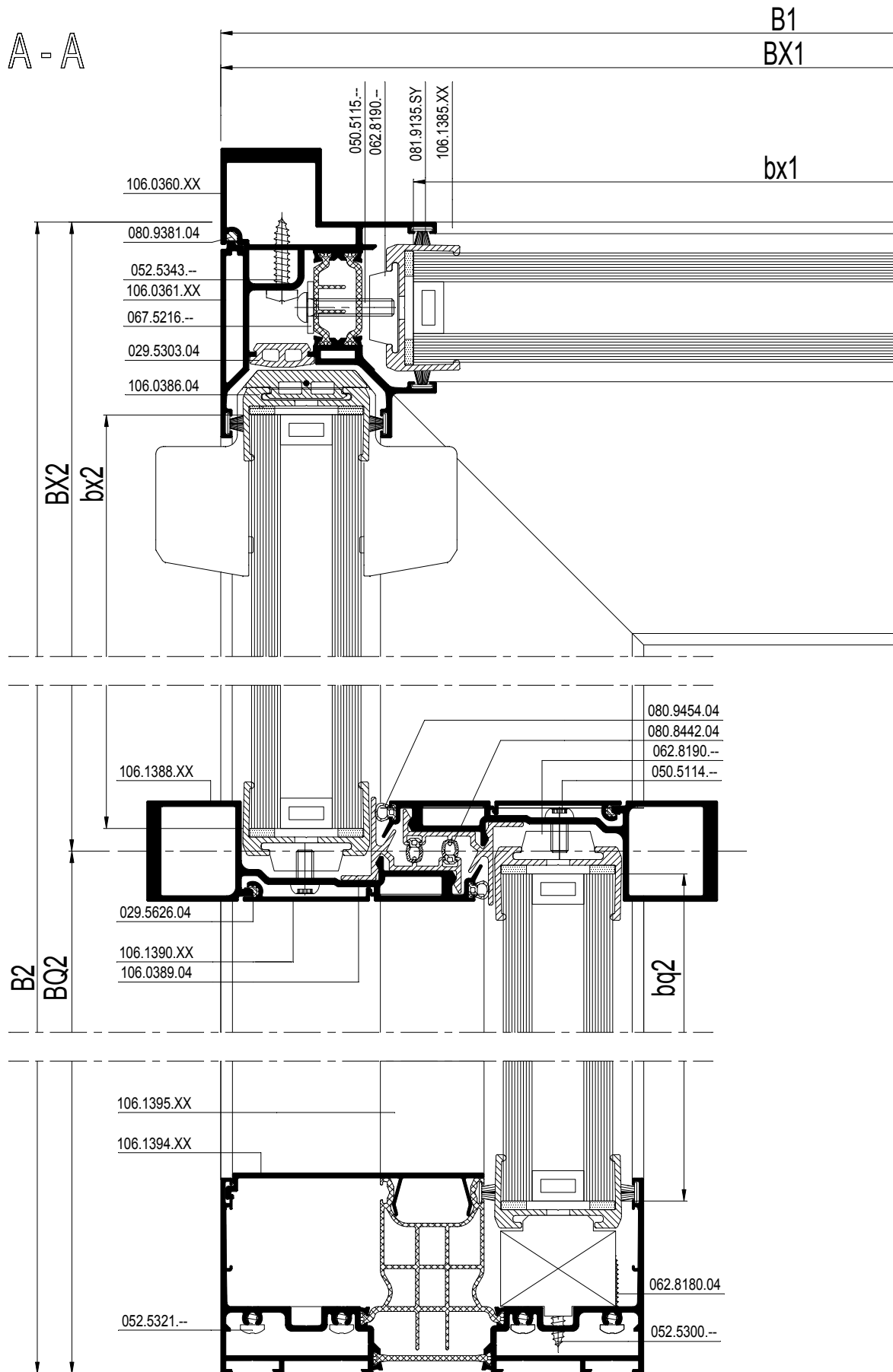

schaal - échelle  
 scale - Maßstab  
 1/2

D2000455

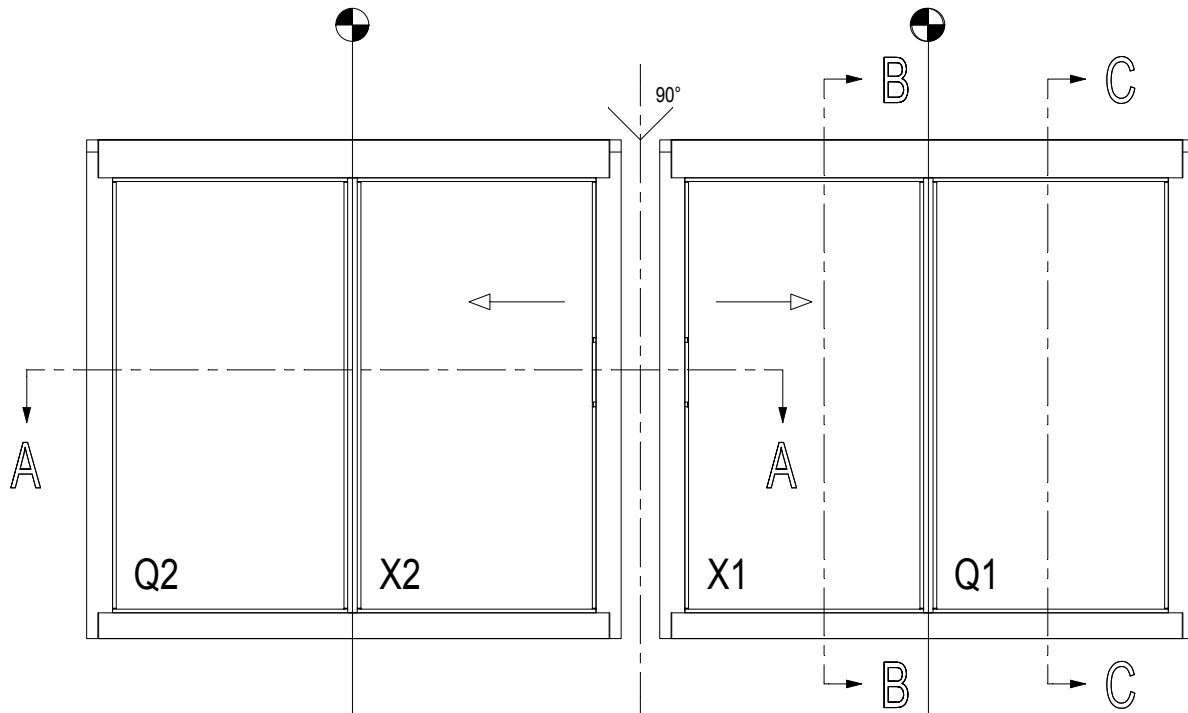

B - B

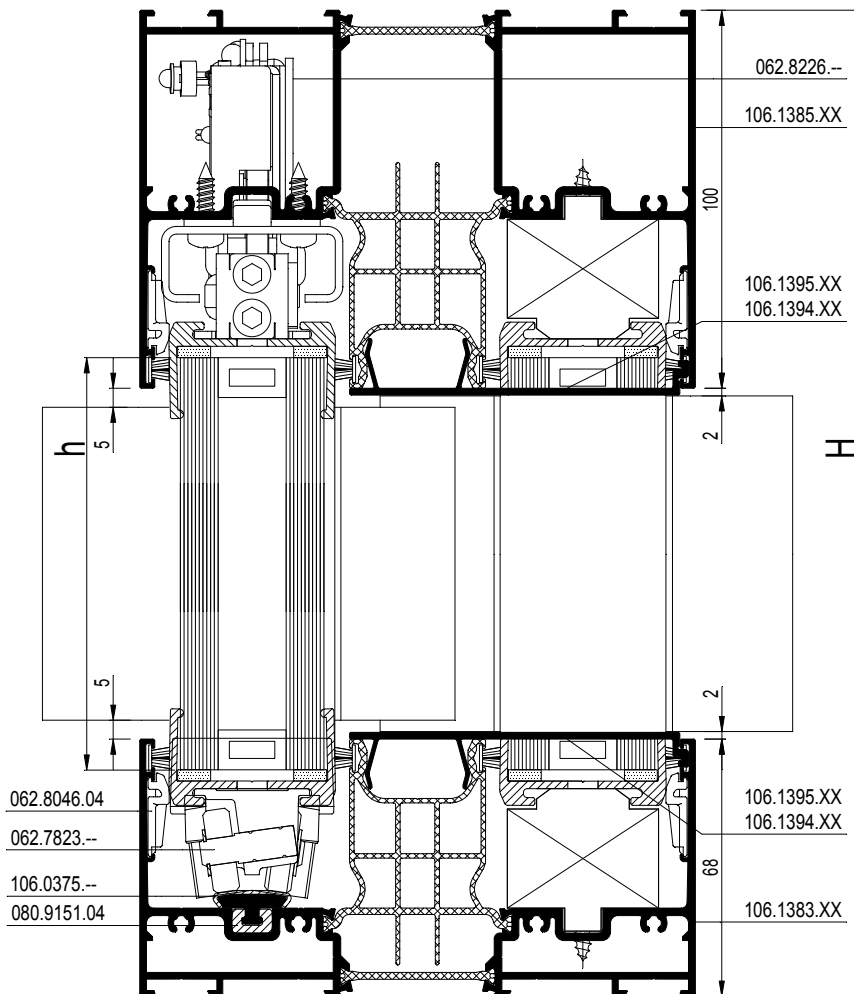

schaal - échelle  
 scale - Maßstab  
 1/2  
 D2000456



		#	
062.7775.--		2	25D.G. ...
062.8226.--		2	25D.G. ...
052.5300.--		8	25D.G. ...
080.9151.04		4 x ( B1 + B2 )	25D.G. ...
081.9135.SY		8 x ( B1 + B2 + H )	25D.G. ...
080.8442.04		4 x H	25D.G. ...
080.9454.04		4 x H	25D.G. ...
062.8190.--		5 x (H/500mm)	25D.G. ...
029.5626.04		4 x H	25D.G. ...
080.9381.04		H	25D.G. ...
062.8180.04		25.F ...	25D.G. ...
052.5300.--		25.F ...	25D.G. ...
062.7823.--		4	25D.G. ...
062.9310.04		25.F ...	25D.G. ...
062.9309.04		4	25D.G. ...
052.5321.--		16	ACCESS CS
062.8046.04		25.F ...	25D.G. ...
062.8176.04		1	25D.G. ...
062.8182.--		2	25D.G. ...
052.5300.--		8	25D.G. ...
062.8081.04		4	25D.G. ...
080.9150.04		H	25D.G. ...
050.5115.--		1 x (H/500mm)	25D.G. ...
067.5216.--		1 x (H/500mm)	25D.G. ...
052.5343.--		1 x (H/300mm)	25D.G. ...
029.5303.04		H	25D.G. ...
062.8087.--		2	25D.G. ...
062.8088.--		2	25D.G. ...
062.9425.--		4	25D.G. ...
062.9426.--		4	25D.G. ...
062.9427.--		2	25D.G. ...
054.5441.04		32	25D.G. ...
050.5094.--		32	25D.G. ...
069.6830.XX		min. 4	25D.G. ...
069.6831.XX		25.F ...	25D.G. ...
084.9114.04		5 x H	25D.G. ...
062.8160.XX		4	25D.G. ...
050.5050.--		4	25D.G. ...
062.8161.XX		4	25D.G. ...
052.5333.--		8	25D.G. ...

### Outside Corner

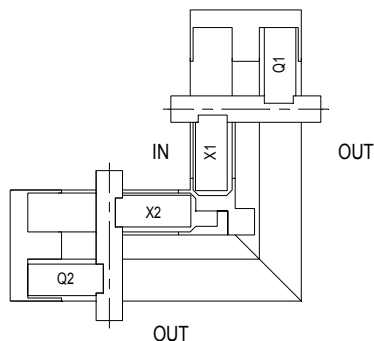

bx1 = BX1 - 162.5
bq1 = BQ1 - 68
bx2 = BX2 - 162.5
bq2 = BQ2 - 68
h = H - 152

### Inside Corner

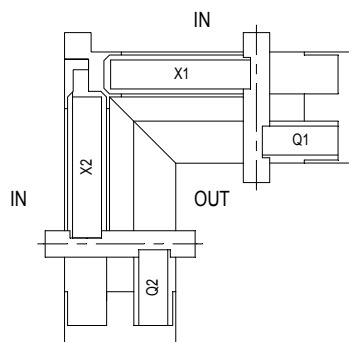

bx1 = BX1 - 75
bq1 = BQ1 - 68
bx2 = BX2 - 75
bq2 = BQ2 - 68
h = H - 152

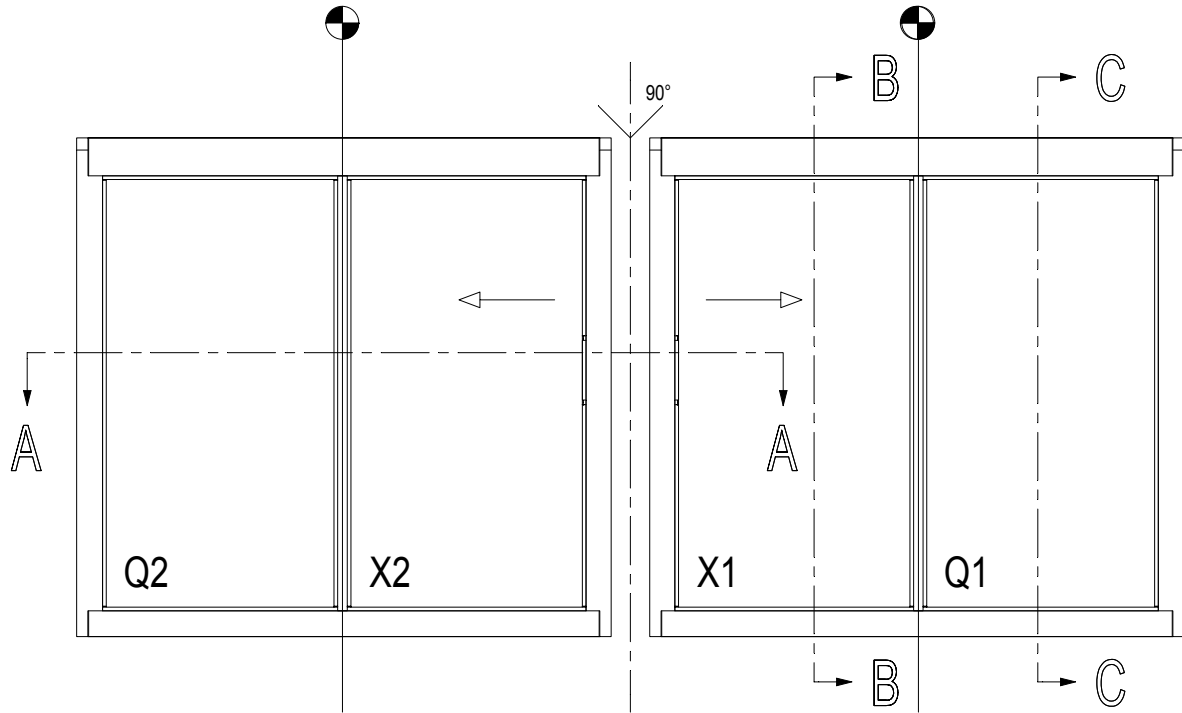

C - C

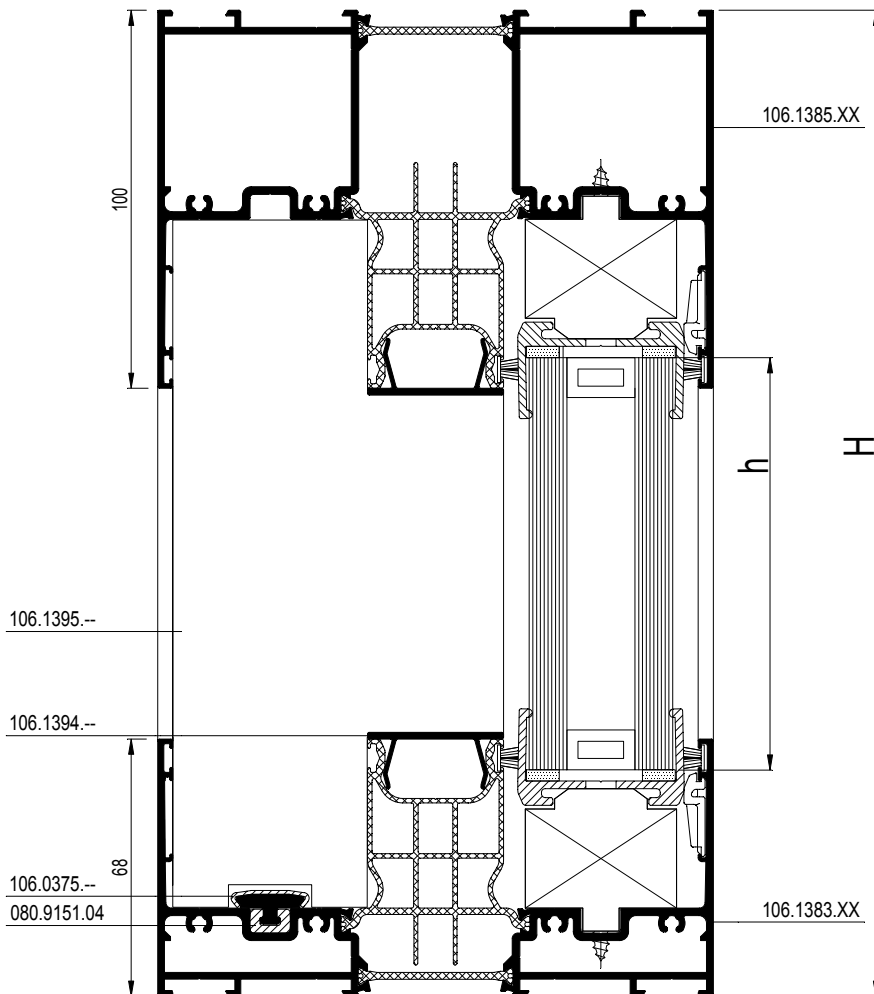

schaal - échelle  
 scale - Maßstab  
 1/2  
 D2000491

## Outside Corner

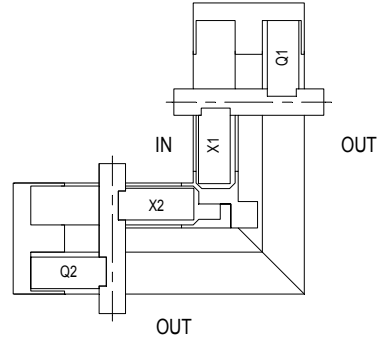

$bx1 = BX1 - 162.5$
$bq1 = BQ1 - 68$
$bx2 = BX2 - 162.5$
$bq2 = BQ2 - 68$
$h = H - 152$

## Inside Corner

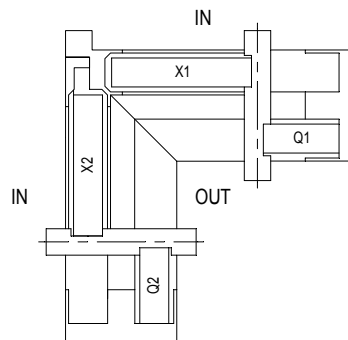

$bx1 = BX1 - 75$
$bq1 = BQ1 - 68$
$bx2 = BX2 - 75$
$bq2 = BQ2 - 68$
$h = H - 152$

### METHOD 1

$bq1 = BQ1 - 19^*$
$bx1 = BX1 - 68$
$bq2 = BQ2 - 27 - d1^*$
$bx2 = BX2 - 68$
$h = H - 152$

AS SHOWN ON ALL  
E-PAGES

			#	$L_m$	
106.1383.XX			2	H - 32	25D.C. ...
			1	B1 - 25	
			1	B2 - 25	
106.1385.XX			1	B1 - 25	25D.C. ...
			1	B2 - 25	
106.1394.XX			2	BX1 - 85	25D.C. ...
			2	BX2 - 85	
			2	H - 168	
106.1395.XX			2	BQ1 - 70	25D.C. ...
			2	BQ2 - 70	
106.0389.04			2	H - 172	25D.C. ...
			2	H - 178	
106.1388.XX			2	H - 172	25D.C. ...
			2	H - 178	
106.1390.XX			2	H - 172	25D.C. ...
			2	H - 114	

		#	
062.9310.04		2	25D.G. ...
062.8087.-		2	25D.G. ...
062.8088.-		2	25D.G. ...
062.9425.-		4	25D.G. ...
062.9426.-		4	25D.G. ...
062.9427.-		2	25D.G. ...

### METHOD 2

$bq1 = BQ1 - 19^*$
$bx1 = BX1 - 68$
$bq2 = BQ2 - 27 - d1^*$
$bx2 = BX2 - 68$
$h = H - 152$

			#	$L_m$	
106.1383.XX			2	H	25D.C. ...
			1	B1 - 25	
			1	B2 - 25	
106.1385.XX			1	B1 - 25	25D.C. ...
			1	B2 - 25	
106.1394.XX			2	BX1 - 85	25D.C. ...
			2	BX2 - 85	
			2	H - 168	
106.1395.XX			2	BQ1 - 70	25D.C. ...
			2	BQ2 - 70	
106.0389.04			2	H - 172	25D.C. ...
			2	H - 178	
106.1388.XX			2	H - 172	25D.C. ...
			2	H - 178	
106.1390.XX			2	H - 172	25D.C. ...
			2	H - 114	

		#	
062.9310.04		0	25D.G. ...
062.8087.-		2	25D.G. ...
062.8088.-		2	25D.G. ...
062.9425.-		4	25D.G. ...
062.9426.-		4	25D.G. ...
062.9427.-		2	25D.G. ...

d1 = thickness outer glass plate  
\* step glass

				#	$L_m$	
106.1383.XX				2	H - 64	25D.C. ...
106.1385.XX				2	B1 - 25	25D.C. ...
106.1394.XX				2	BX1 - 85	25D.C. ...
				2	BX2 - 85	
106.1395.XX				2	BQ1 - 70	25D.C. ...
				2	BQ2 - 70	
106.0389.04				2	H - 204	25D.C. ...
106.1388.XX				2	H - 210	25D.C. ...
				2	H - 204	
106.1390.XX				2	H - 204	25D.C. ...
				2	H - 146	

METHOD 1  
300 Pa

$bq1 = BQ1 - 19^*$
$bx1 = BX1 - 68$
$bq2 = BQ2 - 27 - d1^*$
$bx2 = BX2 - 68$
$h = H - 184$

			#	
062.9310.04			4	25D.G. ...
062.8087.--			0	25D.G. ...
062.8088.--			4	25D.G. ...
062.9425.--			0	25D.G. ...
062.9426.--			8	25D.G. ...
062.9427.--			4	25D.G. ...

				#	$L_m$	
106.1383.XX				2	H	25D.C. ...
106.1385.XX				2	B1 - 25	25D.C. ...
106.1394.XX				2	BX1 - 85	25D.C. ...
				2	BX2 - 85	
106.1395.XX				2	BQ1 - 70	25D.C. ...
				2	BQ2 - 70	
106.0389.04				2	H - 204	25D.C. ...
106.1388.XX				2	H - 210	25D.C. ...
				2	H - 204	
106.1390.XX				2	H - 204	25D.C. ...
				2	H - 146	

METHOD 2  
300 Pa

$bq1 = BQ1 - 19^*$
$bx1 = BX1 - 68$
$bq2 = BQ2 - 27 - d1^*$
$bx2 = BX2 - 68$
$h = H - 184$

			#	
062.9310.04			0	25D.G. ...
062.8087.--			0	25D.G. ...
062.8088.--			4	25D.G. ...
062.9425.--			0	25D.G. ...
062.9426.--			8	25D.G. ...
062.9427.--			4	25D.G. ...

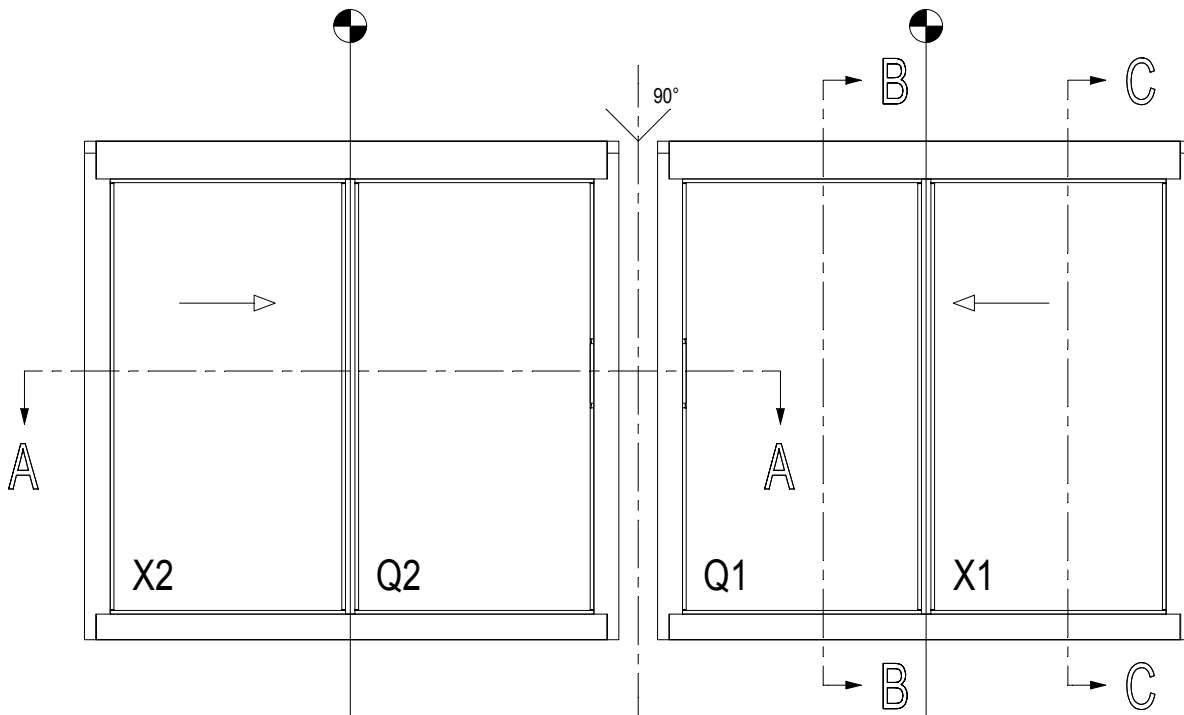

			#	$\leftarrow L_m \rightarrow$	
106.1383.XX			2	H - 32	25D.C. ...
			1	B1 - 25	
			1	B2 - 25	
106.1385.XX			1	B1 - 25	25D.C. ...
			1	B2 - 25	
106.1394.XX			2	H - 168	25D.C. ...
			2	BX1 - 85	
			2	BX2 - 85	
106.1395.XX			2	BQ1 - 70	25D.C. ...
			2	BQ2 - 70	
106.1388.XX			2	H - 172	25D.C. ...
			2	H - 178	
106.1390.XX			2	H - 172	25D.C. ...
			2	H - 114	
106.1390.XX			2	H - 172	25D.C. ...
			2	H - 114	
106.0375.--			1	B1 - 131	25D.C. ...
			1	B2 - 131	

## Outside Corner

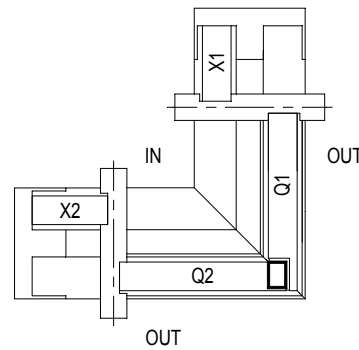

bq1 = BQ1 - 19 *
bx1 = BX1 - 68
bq2 = BQ2 - 27 - d1
bx2 = BX2 - 68
h = H - 152

d1 = thickness outer glass plate  
 \* step glass

A - A

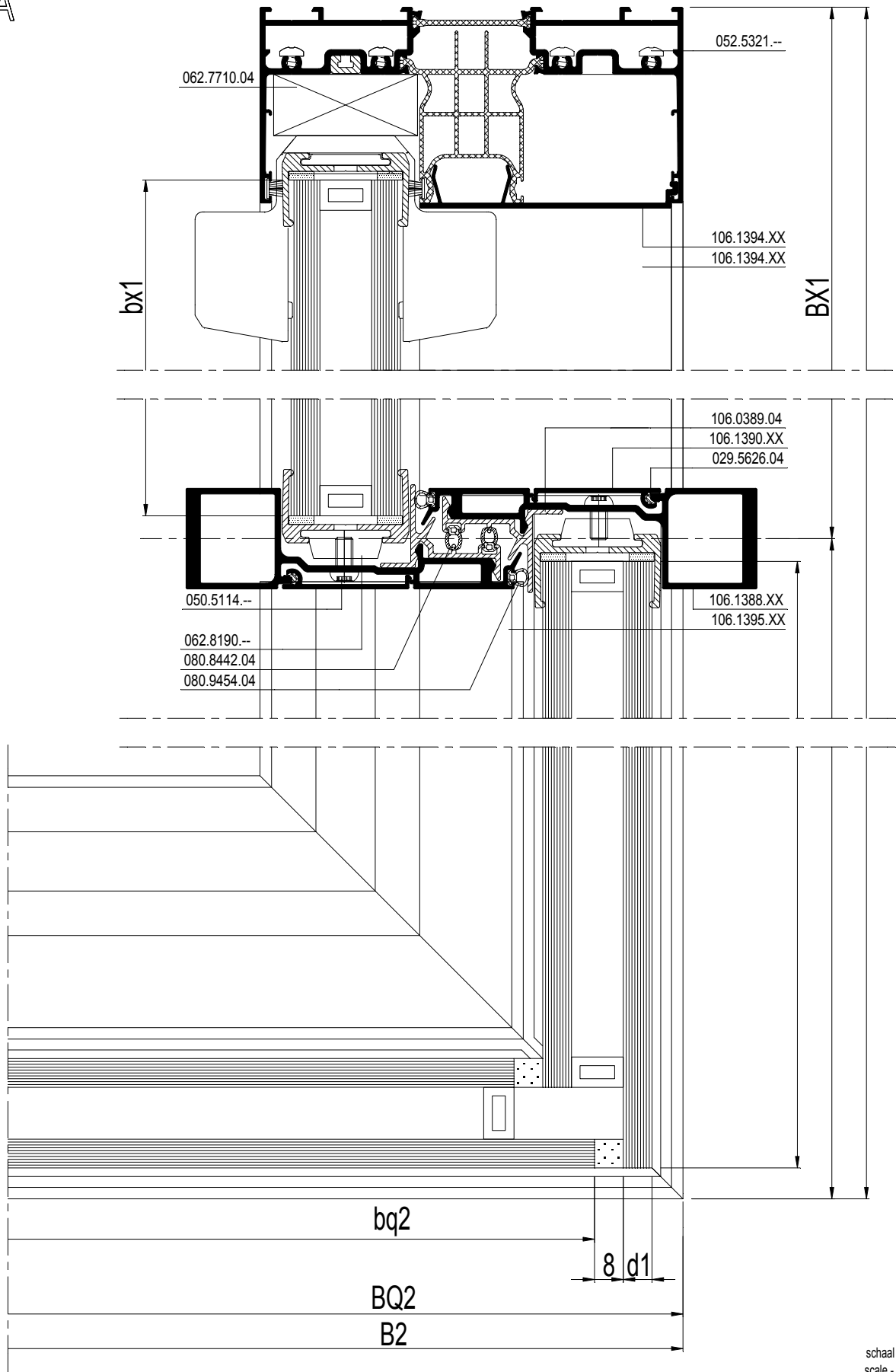

schaal - échelle  
 scale - Maßstab  
 1/2

D2000492

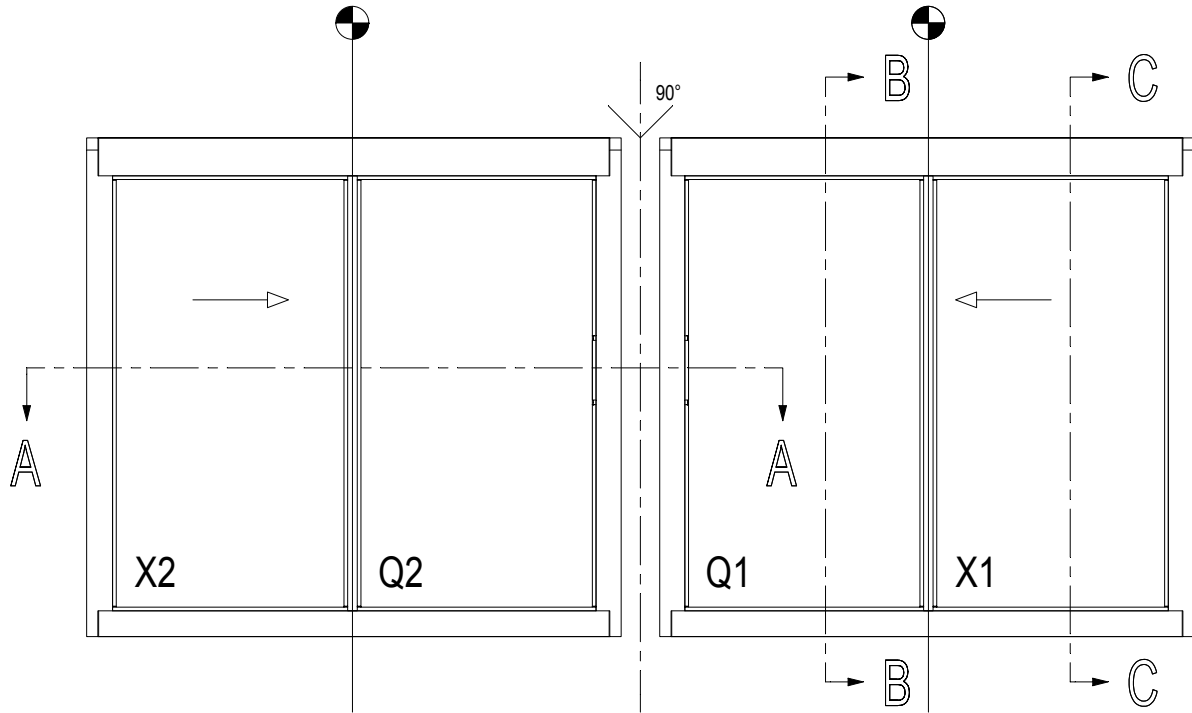

## B - B

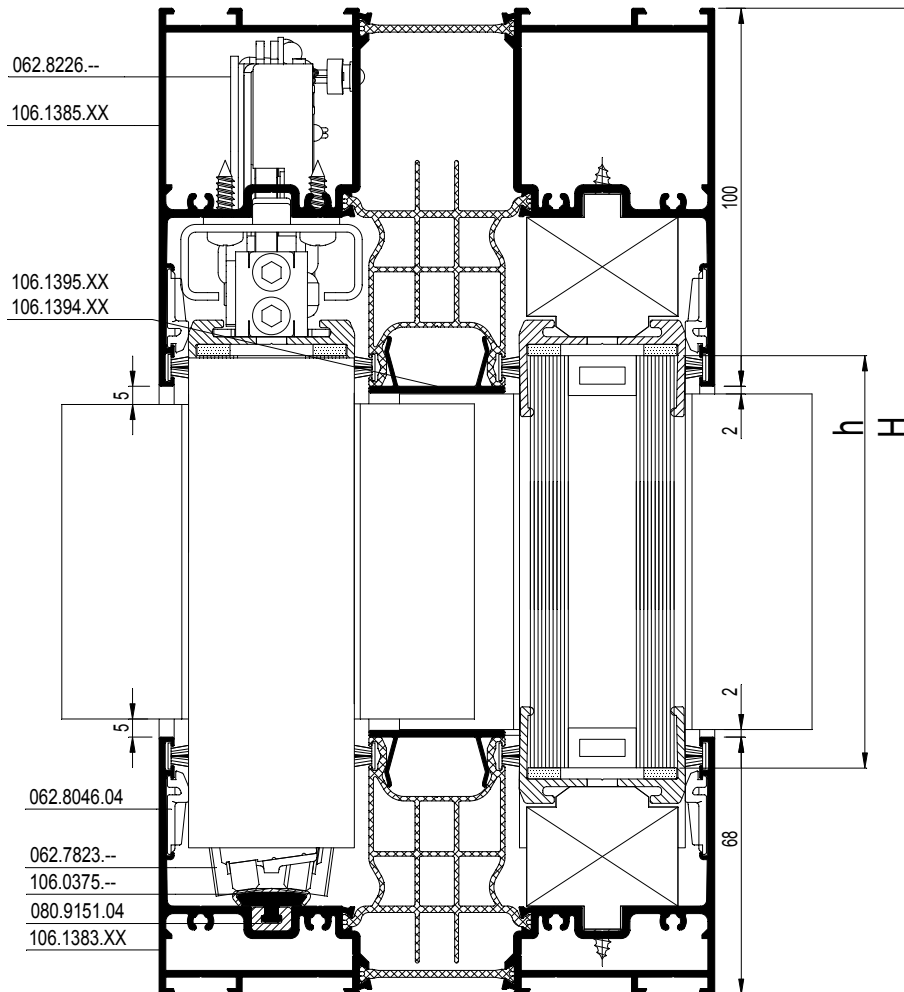

schaal - échelle  
 scale - Maßstab  
 1/2  
 D20000520



		#	
062.7775.--		4	25D.G. ...
062.8226.--		2	25D.G. ...
052.5300.--		8	25D.G. ...
080.9151.04		4 x ( B1 + B2 )	25D.G. ...
081.9135.SY		8 x ( B1 + B2 + H )	25D.G. ...
080.8442.04		4 x H	25D.G. ...
080.9454.04		4 x H	25D.G. ...
062.8190.--		5 x ( H/500mm )	25D.G. ...
029.5626.04		4 x H	25D.G. ...
062.7710.04		4	25D.G. ...
052.5300.--		8	25D.G. ...
062.8180.04		25.F ...	25D.G. ...
052.5300.--		25.F ...	25D.G. ...
062.7823.--		4	25D.G. ...
062.9310.04		25.F ...	25D.G. ...
062.9309.04		4	25D.G. ...
052.5321.--		16	ACCESS CS
062.8046.04		25.F ...	25D.G. ...
062.8176.04		1	25D.G. ...
062.8182.--		2	25D.G. ...
052.5300.--		8	25D.G. ...
062.8081.04		4	25D.G. ...
080.9150.04		2 x H	25D.G. ...
052.5343.--		1 x ( H/300mm )	25D.G. ...
062.8087.--		2	25D.G. ...
062.8088.--		2	25D.G. ...
062.9425.--		4	25D.G. ...
062.9426.--		4	25D.G. ...
062.9427.--		2	25D.G. ...
054.5441.04		32	25D.G. ...
050.5094.--		32	25D.G. ...
069.6830.XX		min. 4	25D.G. ...
069.6831.XX		25.F ...	25D.G. ...
084.9114.04		4 x H	25D.G. ...
062.8160.XX		4	25D.G. ...
050.5050.--		4	25D.G. ...
062.8161.XX		4	25D.G. ...
052.5333.--		8	25D.G. ...

## Outside Corner

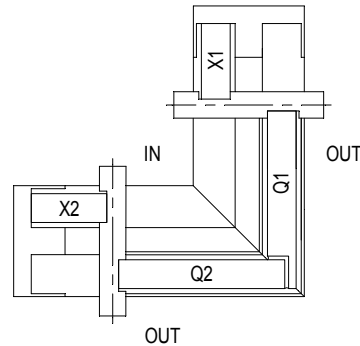

$bq1 = BQ1 - 19^*$
$bx1 = BX1 - 68$
$bq2 = BQ2 - 27 - d1$
$bx2 = BX2 - 68$
$h = H - 152$

## Inside Corner

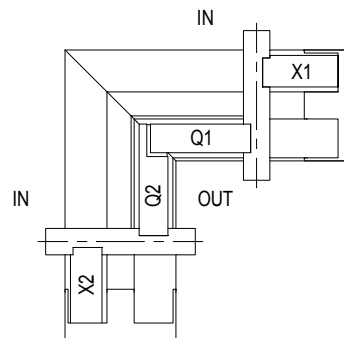

$bq1 = BQ1 - 114.5 - d1$
$bx1 = BX1 - 68$
$bq2 = BQ2 - 106.5^*$
$bx2 = BX2 - 68$
$h = H - 152$

d1 = thickness outer glass plate

\* step glass

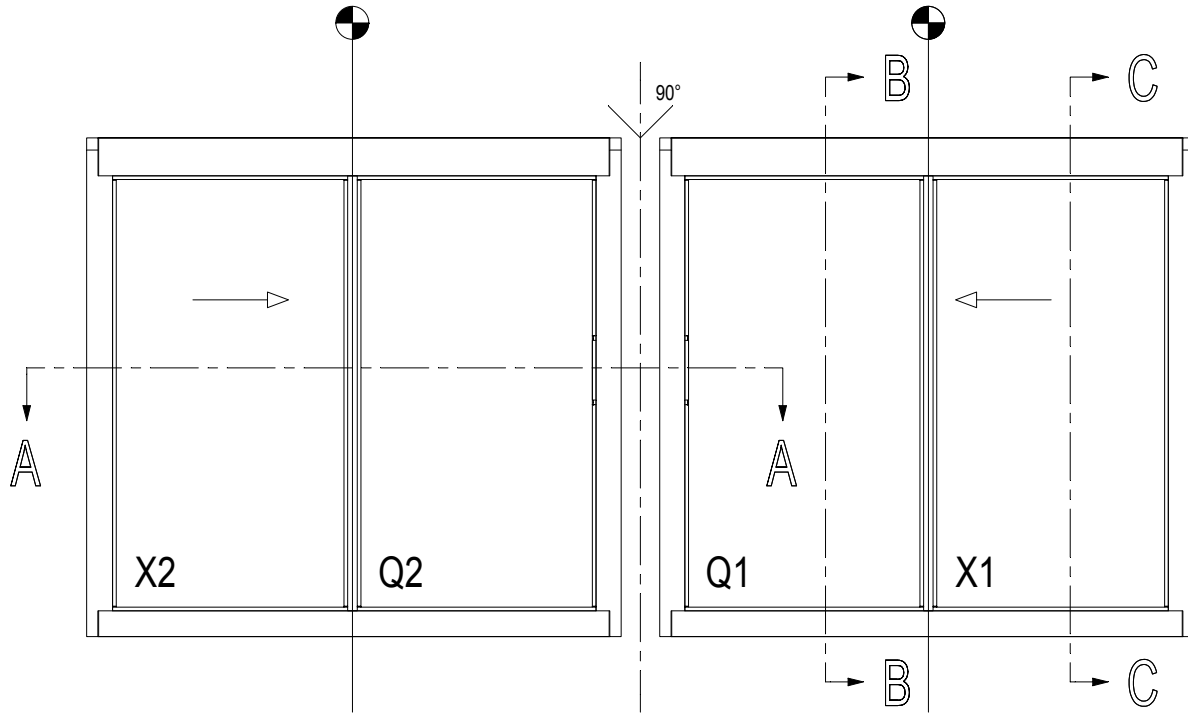

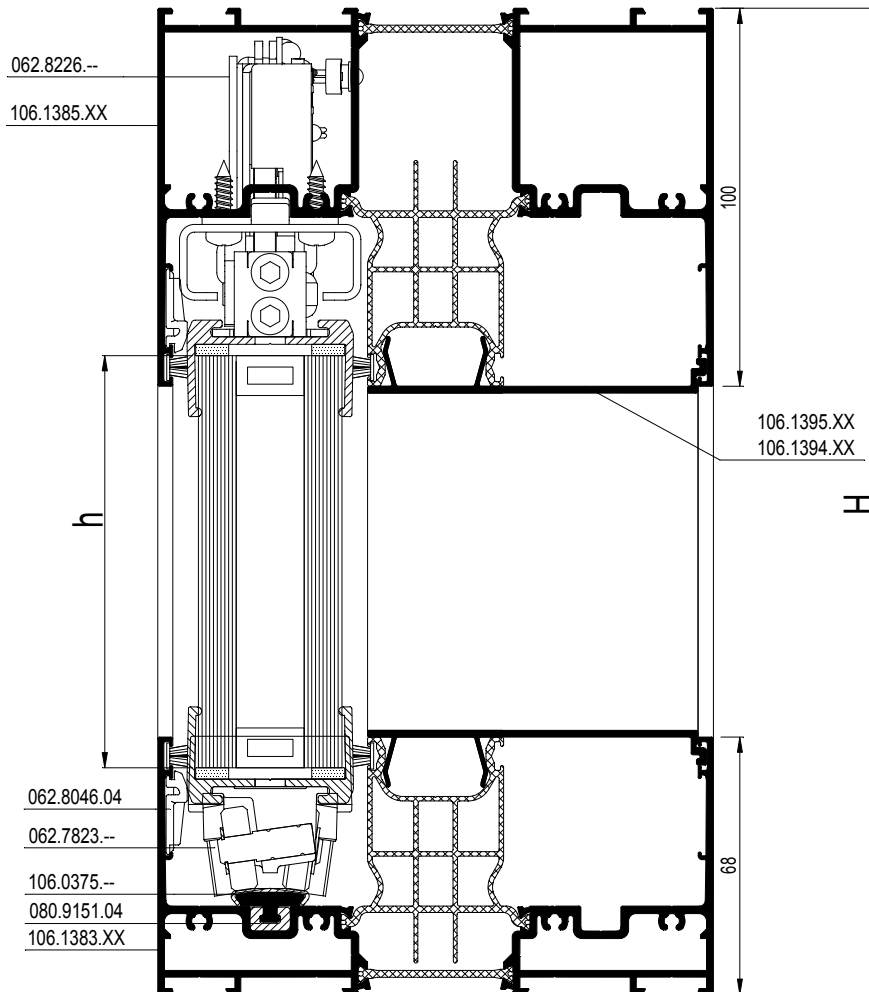

C - C

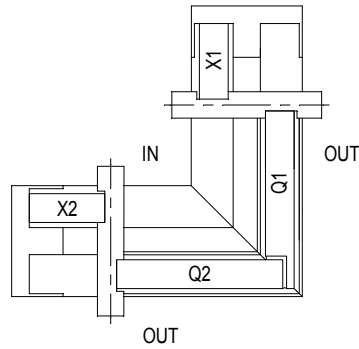

schaal - échelle  
 scale - Maßstab  
 1/2  
 D20000521

## Outside Corner



$bq1 = BQ1 - 19^*$
$bx1 = BX1 - 68$
$bq2 = BQ2 - 27 - d1$
$bx2 = BX2 - 68$
$h = H - 152$

## Inside Corner

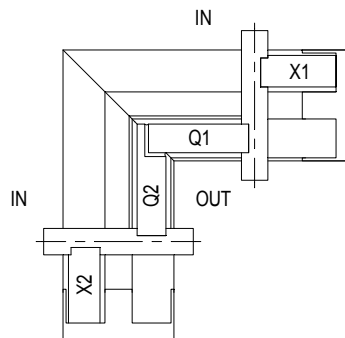

$bq1 = BQ1 - 114.5 - d1$
$bx1 = BX1 - 68$
$bq2 = BQ2 - 106.5^*$
$bx2 = BX2 - 68$
$h = H - 152$

d1 = thickness outer glass plate  
 \* step glass

schaal - échelle  
 scale - Maßstab  
 1/2

D2000521

## METHOD 1

$bq1 = BQ1 - 114.5 - d1 *$
$bx1 = BX1 - 68$
$bq2 = BQ2 - 106.5 *$
$bx2 = BX2 - 68$
$h = H - 152$

AS SHOWN ON ALL  
E-PAGES

			#	$\leftarrow L_m \rightarrow$	
106.1383.XX			2	H - 32	25D.C. ...
			1	B1 - 25	
			1	B2 - 25	
106.1385.XX			1	B1 - 25	25D.C. ...
			1	B2 - 25	
106.1394.XX			2	BX1 - 85	25D.C. ...
			2	BX2 - 85	
			2	H - 168	
106.1395.XX			2	BQ1 - 70	25D.C. ...
			2	BQ2 - 70	
106.0389.04			2	H - 172	25D.C. ...
			2	H - 178	
106.1388.XX			2	H - 172	25D.C. ...
			2	H - 178	
106.1390.XX			2	H - 172	25D.C. ...
			2	H - 114	

		#	
062.9310.04		2	25D.G. ...
062.8087.-		2	25D.G. ...
062.8088.-		2	25D.G. ...
062.9425.-		4	25D.G. ...
062.9426.-		4	25D.G. ...
062.9427.-		2	25D.G. ...

## METHOD 2

$bq1 = BQ1 - 114.5 - d1 *$
$bx1 = BX1 - 68$
$bq2 = BQ2 - 106.5 *$
$bx2 = BX2 - 68$
$h = H - 152$

			#	$\leftarrow L_m \rightarrow$	
106.1383.XX			2	H	25D.C. ...
			1	B1 - 25	
			1	B2 - 25	
106.1385.XX			1	B1 - 25	25D.C. ...
			1	B2 - 25	
106.1394.XX			2	BX1 - 85	25D.C. ...
			2	BX2 - 85	
			2	H - 168	
106.1395.XX			2	BQ1 - 70	25D.C. ...
			2	BQ2 - 70	
106.0389.04			2	H - 172	25D.C. ...
			2	H - 178	
106.1388.XX			2	H - 172	25D.C. ...
			2	H - 178	
106.1390.XX			2	H - 172	25D.C. ...
			2	H - 114	

		#	
062.9310.04		0	25D.G. ...
062.8087.-		2	25D.G. ...
062.8088.-		2	25D.G. ...
062.9425.-		4	25D.G. ...
062.9426.-		4	25D.G. ...
062.9427.-		2	25D.G. ...

d1 = thickness outer glass plate  
\* step glass

				#	$\rightarrow L_m \rightarrow$	
106.1383.XX				2	H - 64	25D.C. ...
106.1385.XX				2	B1 - 25	25D.C. ...
106.1394.XX				2	BX1 - 85	25D.C. ...
				2	BX2 - 85	
106.1395.XX				2	BQ1 - 70	25D.C. ...
				2	BQ2 - 70	
106.0389.04				2	H - 204	25D.C. ...
106.1388.XX				2	H - 210	25D.C. ...
				2	H - 204	
106.1390.XX				2	H - 204	25D.C. ...
				2	H - 146	

METHOD 1  
300 Pa

$bq1 = BQ1 - 114.5 - d1 *$
$bx1 = BX1 - 68$
$bq2 = BQ2 - 106.5 *$
$bx2 = BX2 - 68$
$h = H - 184$

			#	
062.9310.04			4	25D.G. ...
062.8087.--			0	25D.G. ...
062.8088.--			4	25D.G. ...
062.9425.--			0	25D.G. ...
062.9426.--			8	25D.G. ...
062.9427.--			4	25D.G. ...

				#	$\rightarrow L_m \rightarrow$	
106.1383.XX				2	H	25D.C. ...
106.1385.XX				2	B1 - 25	25D.C. ...
106.1394.XX				2	BX1 - 85	25D.C. ...
				2	BX2 - 85	
106.1395.XX				2	BQ1 - 70	25D.C. ...
				2	BQ2 - 70	
106.0389.04				2	H - 204	25D.C. ...
106.1388.XX				2	H - 210	25D.C. ...
				2	H - 204	
106.1390.XX				2	H - 204	25D.C. ...
				2	H - 146	

METHOD 2  
300 Pa

$bq1 = BQ1 - 114.5 - d1 *$
$bx1 = BX1 - 68$
$bq2 = BQ2 - 106.5 *$
$bx2 = BX2 - 68$
$h = H - 184$

			#	
062.9310.04			0	25D.G. ...
062.8087.--			0	25D.G. ...
062.8088.--			4	25D.G. ...
062.9425.--			0	25D.G. ...
062.9426.--			8	25D.G. ...
062.9427.--			4	25D.G. ...

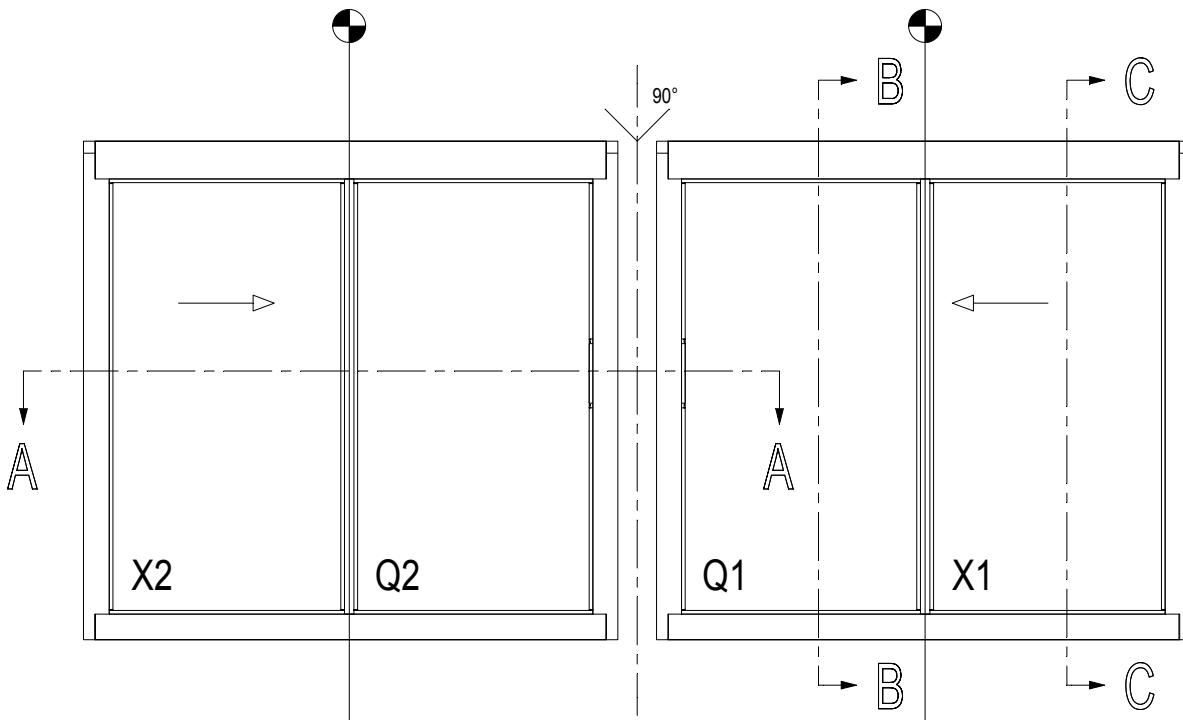

			#	$\leftarrow L_m \rightarrow$	
106.1383.XX			2	H - 32	25D.C. ...
			1	B1 - 25	
			1	B2 - 25	
106.1385.XX			1	B1 - 25	25D.C. ...
			1	B2 - 25	
106.1394.XX			2	H - 168	25D.C. ...
			2	BX1 - 85	
			2	BX2 - 85	
106.1395.XX			2	BQ1 - 70	25D.C. ...
			2	BQ2 - 70	
106.1388.XX			2	H - 172	25D.C. ...
			2	H - 178	
106.1390.XX			2	H - 172	25D.C. ...
			2	H - 114	
106.1390.XX			2	H - 172	25D.C. ...
			2	H - 114	
106.0375.-			1	B1 - 43.5	25D.C. ...
			1	B2 - 43.5	

### Inside Corner

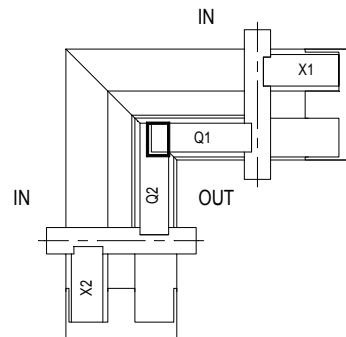

bq1 = BQ1 - 114.5 - d1
bx1 = BX1 - 68
bq2 = BQ2 - 106.5*
bx2 = BX2 - 68
h = H - 152

d1 = thickness outer glass plate  
 \* step glass

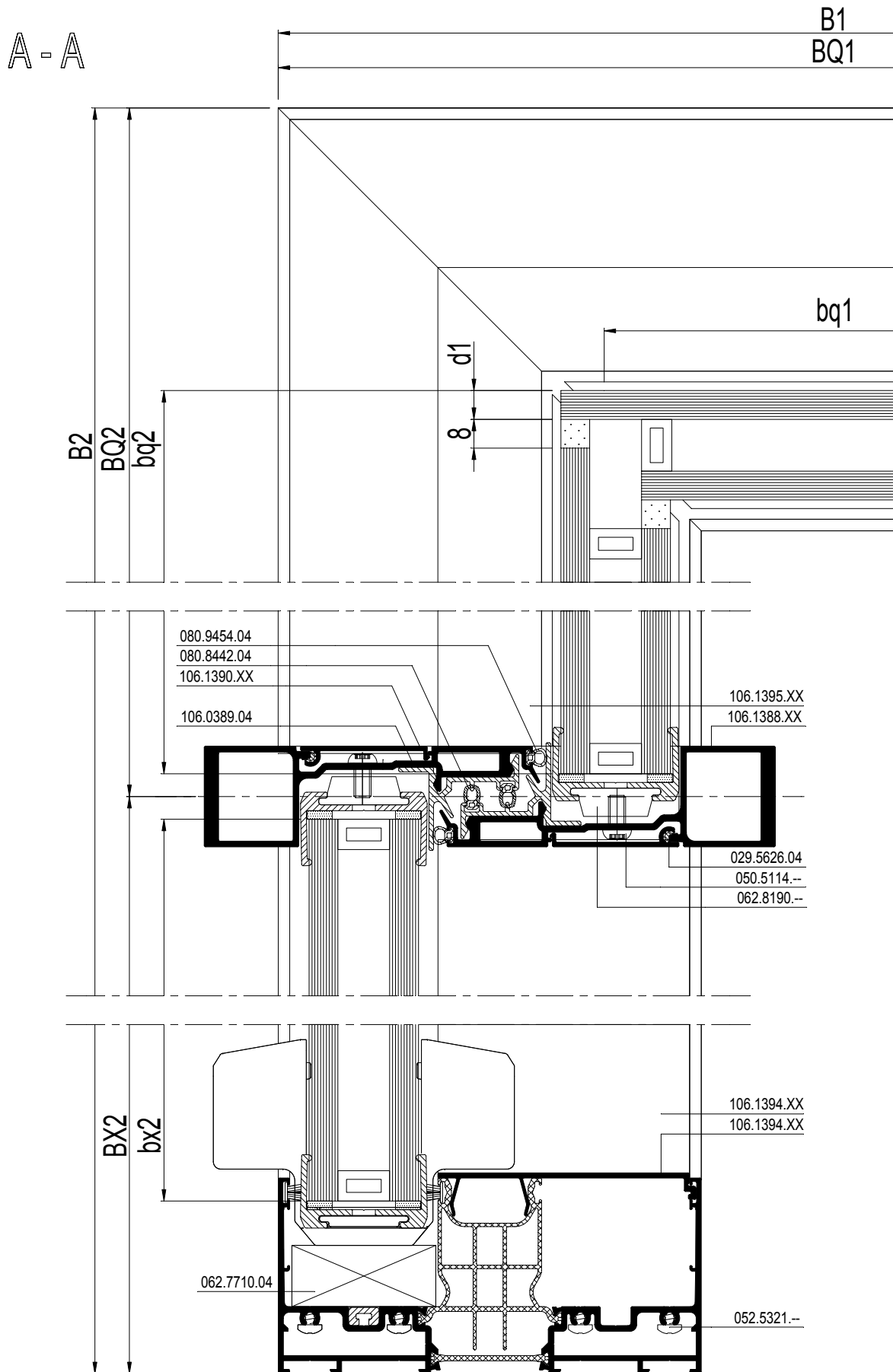

schaal - échelle  
 scale - Maßstab  
 1/2

D2000481

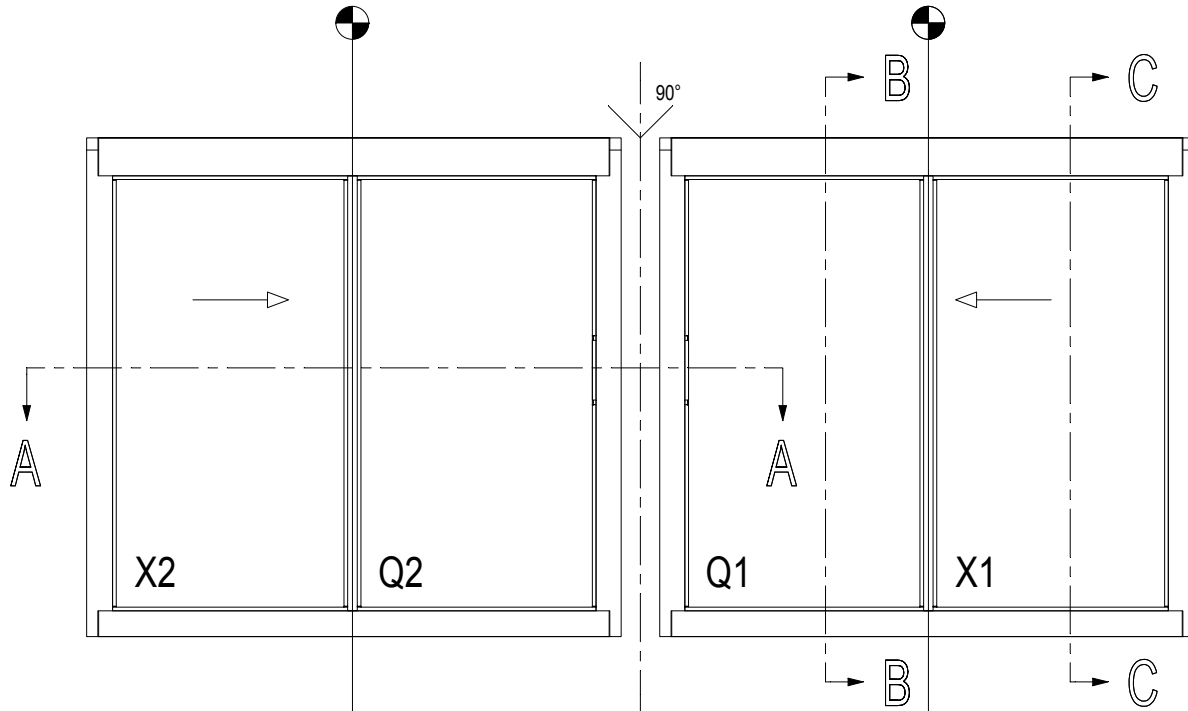

## B - B

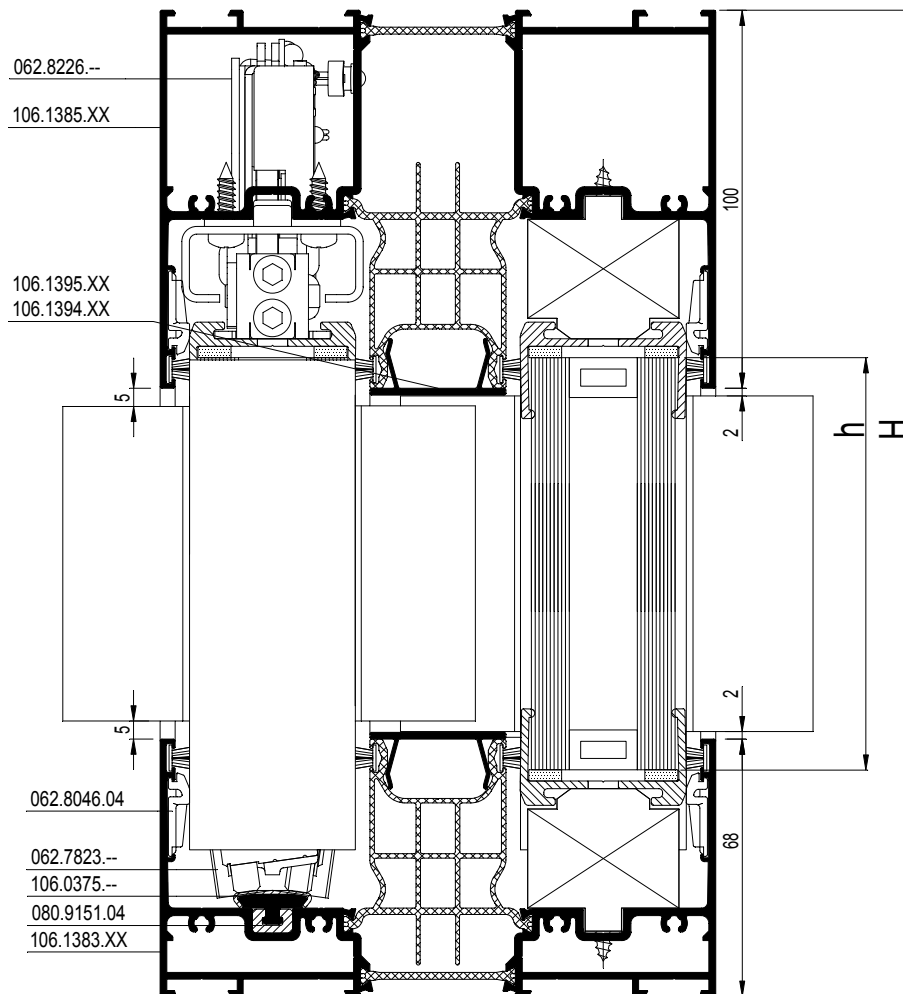

schaal - échelle  
 scale - Maßstab  
 1/2  
 D20000511



		#	
062.7775.--		4	25D.G. ...
062.8226.--		2	25D.G. ...
052.5300.--		8	25D.G. ...
080.9151.04		4 x ( B1 + B2 )	25D.G. ...
081.9135.SY		8 x ( B1 + B2 + H )	25D.G. ...
080.8442.04		4 x H	25D.G. ...
080.9454.04		4 x H	25D.G. ...
062.8190.--		5 x ( H/500mm )	25D.G. ...
029.5626.04		4 x H	25D.G. ...
062.7710.04		4	25D.G. ...
052.5300.--		8	25D.G. ...
062.8180.04		25.F ...	25D.G. ...
052.5300.--		25.F ...	25D.G. ...
062.7823.--		4	25D.G. ...
062.9310.04		25.F ...	25D.G. ...
062.9309.04		4	25D.G. ...
052.5321.--		16	ACCESS CS
062.8046.04		25.F ...	25D.G. ...
062.8176.04		1	25D.G. ...
062.8182.--		2	25D.G. ...
052.5300.--		8	25D.G. ...
062.8081.04		4	25D.G. ...
080.9150.04		2 x H	25D.G. ...
052.5343.--		1 x ( H/300mm )	25D.G. ...
062.8087.--		2	25D.G. ...
062.8088.--		2	25D.G. ...
062.9425.--		4	25D.G. ...
062.9426.--		4	25D.G. ...
062.9427.--		2	25D.G. ...
054.5441.04		32	25D.G. ...
050.5094.--		32	25D.G. ...
069.6830.XX		min. 4	25D.G. ...
069.6831.XX		25.F ...	25D.G. ...
084.9114.04		4 x H	25D.G. ...
062.8160.XX		4	25D.G. ...
050.5050.--		4	25D.G. ...
062.8161.XX		4	25D.G. ...
052.5333.--		8	25D.G. ...

## Outside Corner

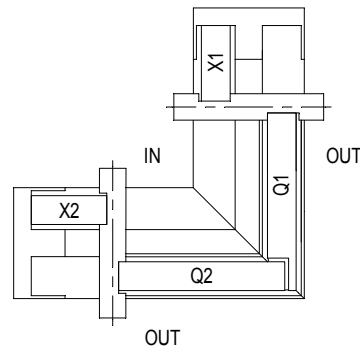

$bq1 = BQ1 - 19^*$
$bx1 = BX1 - 68$
$bq2 = BQ2 - 27 - d1$
$bx2 = BX2 - 68$
$h = H - 152$

## Inside Corner

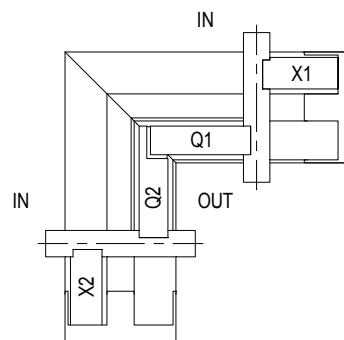

$bq1 = BQ1 - 114.5 - d1$
$bx1 = BX1 - 68$
$bq2 = BQ2 - 106.5^*$
$bx2 = BX2 - 68$
$h = H - 152$

d1 = thickness outer glass plate

\* step glass

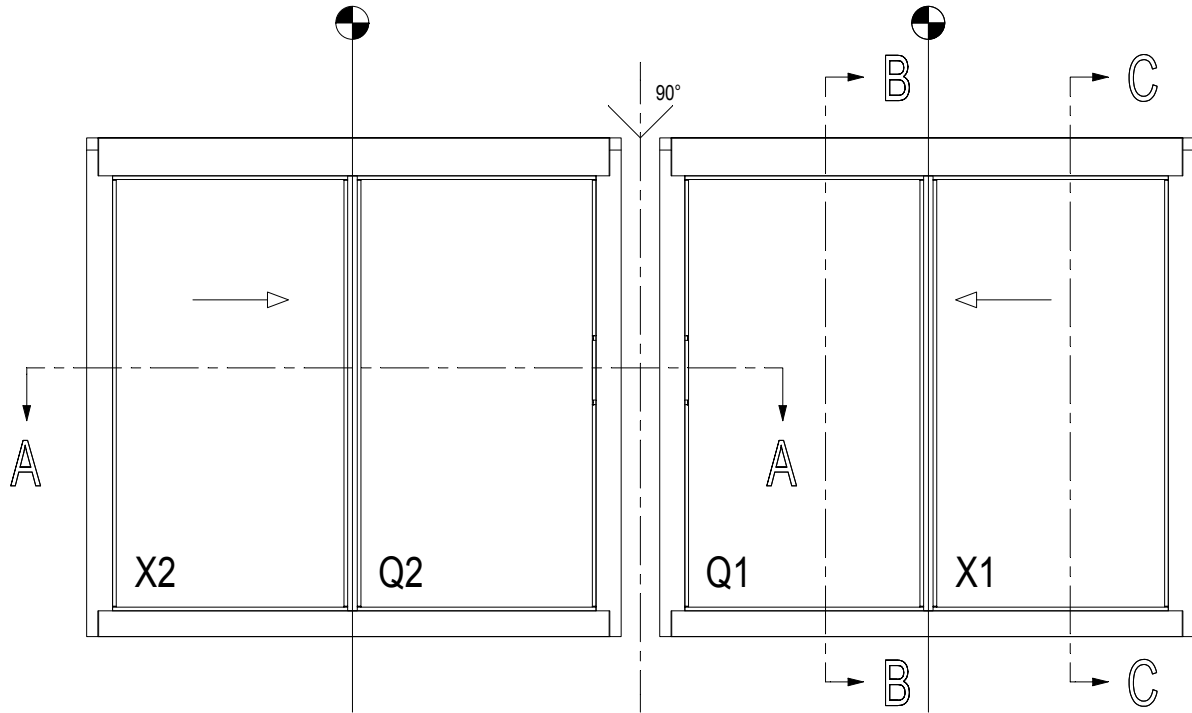

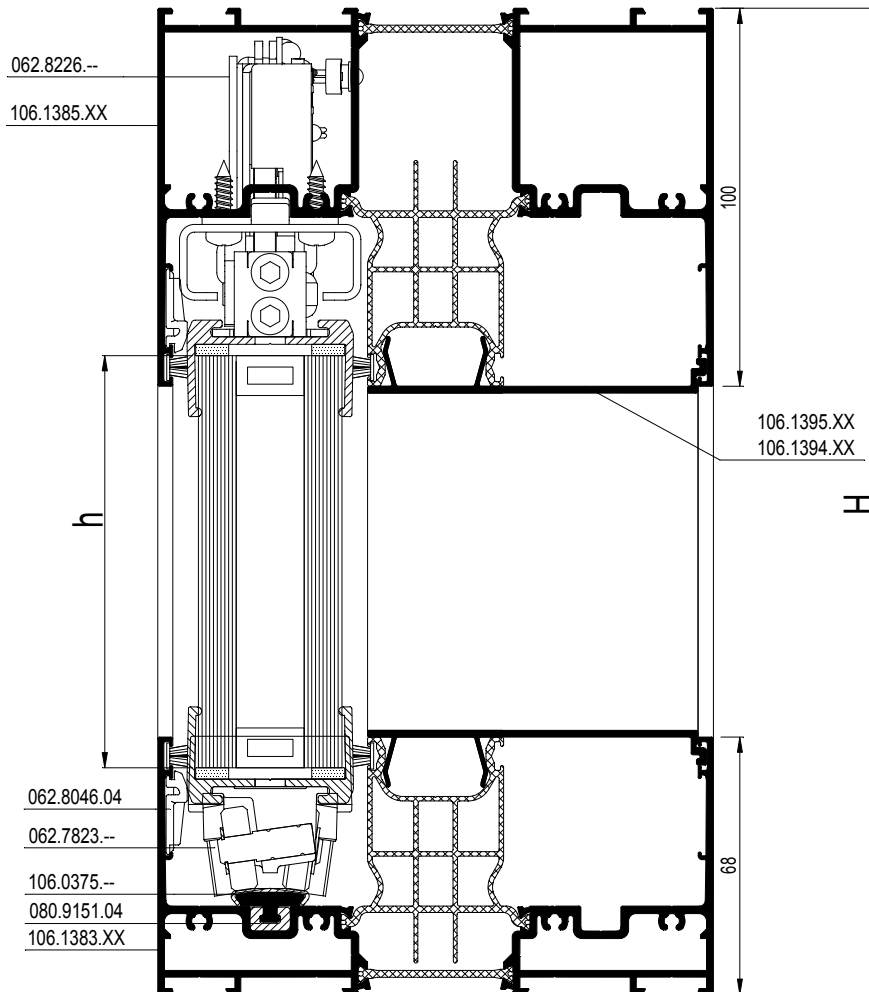

C - C

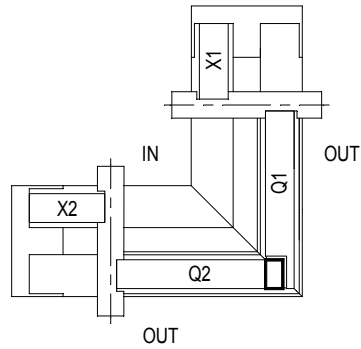

schaal - échelle  
 scale - Maßstab  
 1/2  
 D20000512

## Outside Corner



bq1 = BQ1 - 19 *
bx1 = BX1 - 68
bq2 = BQ2 - 27 - d1
bx2 = BX2 - 68
h = H - 152

## Inside Corner

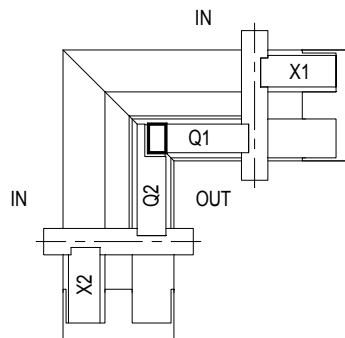

bq1 = BQ1 - 114.5 - d1
bx1 = BX1 - 68
bq2 = BQ2 - 106.5 *
bx2 = BX2 - 68
h = H - 152

d1 = thickness outer glass plate

\* step glass

schaal - échelle  
 scale - Maßstab  
 1/2

D2000512

3-RAIL  
3-RAIL

3-RAIL  
3-RAIL

Fg max (X + O) ≤ 500 KG  
B (O) ≤ B (Q)

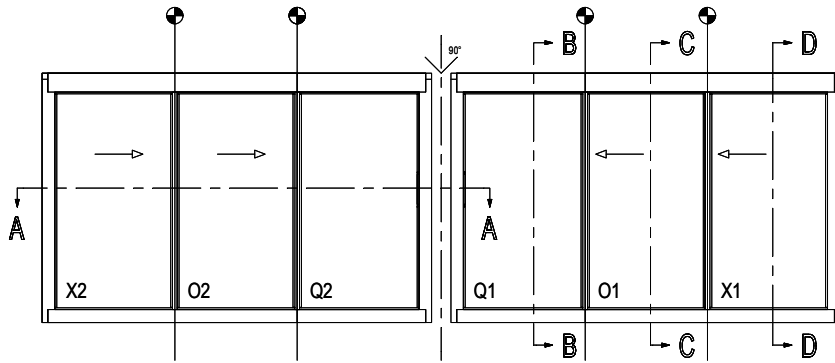

Outside Corner

Inside Corner

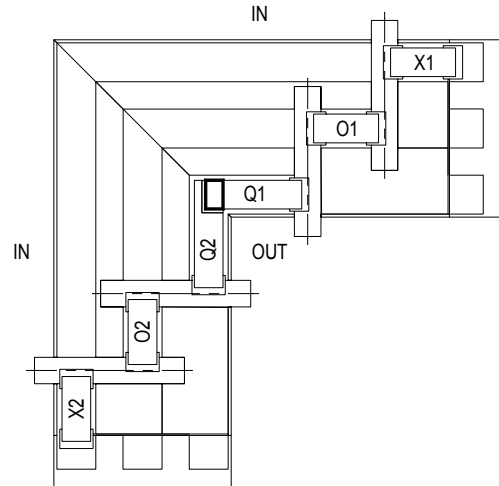
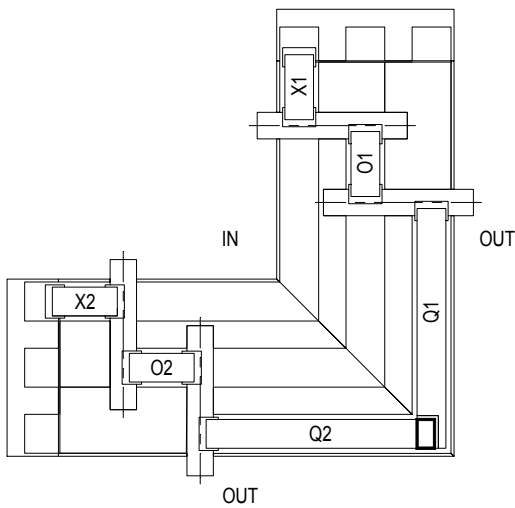

$B(X) = B(O)$

X : PRIMAIRE VLEUGEL  
 Q : VASTE VLEUGEL  
 O : SECUNDAIRE VLEUGEL  
 V : HOEKOPLOSSING

X : OUVRANT PRIMAIRE  
 Q : OUVRANT FIXE  
 O : OUVRANT SECUNDAIRE  
 V : SOLUTION ANGULAIRE

X : PRIMARY SLIDING VENT  
 Q : FIXED VENT  
 O : SECONDARY SLIDING VENT  
 V : CORNER SOLUTION

X : GANGFLUEGEL  
 Q : FENSTER FLUEGEL  
 O : STANDFLUEGEL  
 V : ECKLÖSUNG

3-RAIL  
3-RAIL

3-RAIL  
3-RAIL

Fg max (X + O) ≤ 300 KG  
B (O) ≤ B (Q)

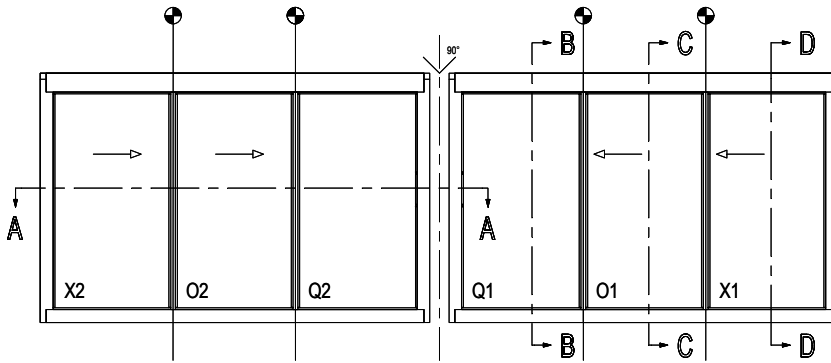

Outside Corner

Inside Corner

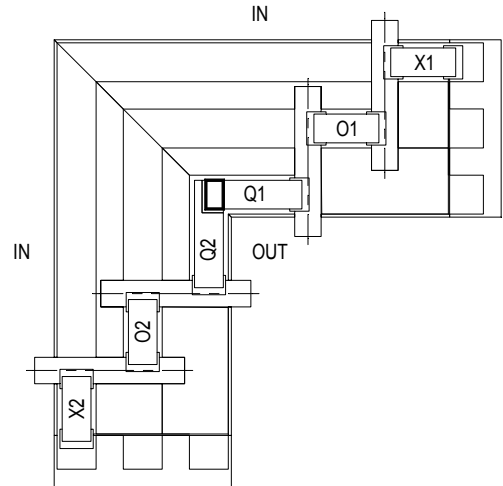
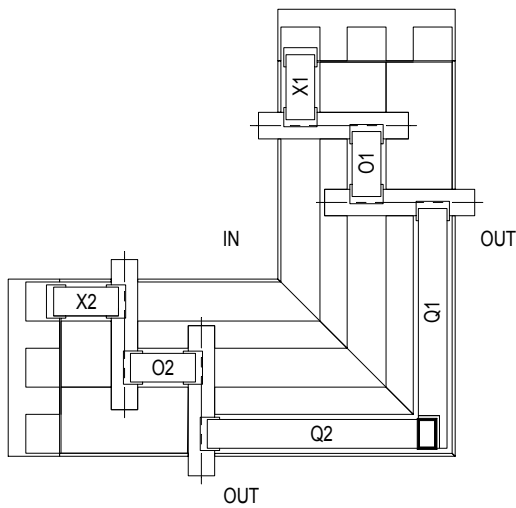

$B(X) = B(O)$

## METHOD 1

AS SHOWN ON ALL  
 E-PAGES

bq1 = BQ1 - 19*
bo1 = BO1 - 16
bx1 = BX1 - 68
bq2 = BQ2 - 27 - d1*
bo2 = BO2 - 16
bx2 = BX2 - 68
h = H - 152

		#	
--	--	---	--

062.9320.04		2	25D.G. ...
062.8087.--		2	25D.G. ...
062.8088.--		2	25D.G. ...
062.9425.--		4	25D.G. ...
062.9426.--		4	25D.G. ...
062.9427.--		2	25D.G. ...
062.9428.--		2	25D.G. ...
062.9429.--		2	25D.G. ...

## METHOD 2

bq1 = BQ1 - 19*
bo1 = BO1 - 16
bx1 = BX1 - 68
bq2 = BQ2 - 27 - d1*
bo2 = BO2 - 16
bx2 = BX2 - 68
h = H - 152

		#	
--	--	---	--

062.9320.04		0	25D.G. ...
062.8087.--		2	25D.G. ...
062.8088.--		2	25D.G. ...
062.9425.--		4	25D.G. ...
062.9426.--		4	25D.G. ...
062.9427.--		2	25D.G. ...
062.9428.--		2	25D.G. ...
062.9429.--		2	25D.G. ...

			#	Lm	
106.1399.XX			2	H - 32	25D.C. ...
			1	B1 - 25	
			1	B2 - 25	
106.1400.XX			1	B1 - 25	25D.C. ...
			1	B2 - 25	
106.1394.XX			4	H - 168	25D.C. ...
			2	B1 - BQ1 - 85	
			2	B2 - BQ2 - 85	
			2	BX1 - 85	
			2	BX2 - 85	
106.1395.XX			2	B1 - BX1 - 158	25D.C. ...
			2	B2 - BX2 - 158	
			2	BQ1 - 70	
			2	BQ2 - 70	
106.1388.XX			2	H - 172	25D.C. ...
		2	H - 178		
106.1390.XX			2	H - 172	25D.C. ...
		2	H - 114		
106.1390.XX			4	H - 172	25D.C. ...
		4	H - 114		

			#	Lm	
106.1399.XX			2	H	25D.C. ...
			1	B1 - 25	
			1	B2 - 25	
106.1400.XX			1	B1 - 25	25D.C. ...
			1	B2 - 25	
106.1394.XX			4	H - 168	25D.C. ...
			2	B1 - BQ1 - 85	
			2	B2 - BQ2 - 85	
			2	BX1 - 85	
			2	BX2 - 85	
106.1395.XX			2	B1 - BX1 - 158	25D.C. ...
			2	B2 - BX2 - 158	
			2	BQ1 - 70	
			2	BQ2 - 70	
106.0389.04			2	H - 172	25D.C. ...
		2	H - 178		
106.1388.XX			2	H - 172	25D.C. ...
		2	H - 178		
106.1390.XX			4	H - 172	25D.C. ...
			4	H - 114	

schaal - échelle  
 scale - Maßstab  
 1/2

D20000505

			#	$\leftarrow L_m \rightarrow$	
106.1399.XX			2	H - 64	25D.C. ...
106.1400.XX			2	B1 - 25	25D.C. ...
			2	B2 - 25	
106.1394.XX			4	H - 200	25D.C. ...
			2	B1 - BQ1 - 85	
			2	B2 - BQ2 - 85	
			2	BX1 - 85	
			2	BX2 - 85	
106.1395.XX			2	B1 - BX1 - 158	25D.C. ...
			2	B2 - BX2 - 158	
			2	BQ1 - 70	
			2	BQ2 - 70	
106.0389.04			2	H - 204	25D.C. ...
106.1388.XX			2	H - 204	25D.C. ...
			2	H - 210	
106.1390.XX			4	H - 204	25D.C. ...
			4	H - 146	

METHOD 1  
300 Pa

bq1 = BQ1 - 19*
bo1 = BO1 - 16
bx1 = BX1 - 68
bq2 = BQ2 - 27 - d1*
bo2 = BO2 - 16
bx2 = BX2 - 68
h = H - 184

		#	
		4	25D.G. ...
		0	25D.G. ...
		4	25D.G. ...
		0	25D.G. ...
		8	25D.G. ...
		4	25D.G. ...
		0	25D.G. ...
		4	25D.G. ...

			#	$\leftarrow L_m \rightarrow$	
106.1399.XX			2	H	25D.C. ...
106.1400.XX			2	B1 - 25	25D.C. ...
			2	B2 - 25	
106.1394.XX			4	H - 200	25D.C. ...
			2	B1 - BQ1 - 85	
			2	B2 - BQ2 - 85	
			2	BX1 - 85	
			2	BX2 - 85	
106.1395.XX			2	B1 - BX1 - 158	25D.C. ...
			2	B2 - BX2 - 158	
			2	BQ1 - 70	
			2	BQ2 - 70	
106.0389.04			2	H - 204	25D.C. ...
106.1388.XX			2	H - 204	25D.C. ...
			2	H - 210	
106.1390.XX			4	H - 204	25D.C. ...
			4	H - 146	

METHOD 2  
300 Pa

bq1 = BQ1 - 19*
bo1 = BO1 - 16
bx1 = BX1 - 68
bq2 = BQ2 - 27 - d1*
bo2 = BO2 - 16
bx2 = BX2 - 68
h = H - 184

		#	
		0	25D.G. ...
		0	25D.G. ...
		4	25D.G. ...
		0	25D.G. ...
		8	25D.G. ...
		4	25D.G. ...
		0	25D.G. ...
		4	25D.G. ...

d1 = thickness outer glass plate  
 \* step glass

schaal - échelle  
 scale - Maßstab  
 1/2

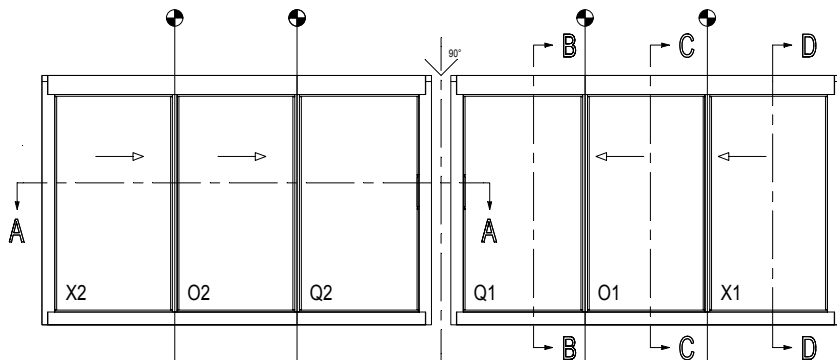

			#	Lm	
106.1399.XX			2	H-32	25D.C. ...
			1	B1 - 25	
			1	B2 - 25	
106.1400.XX			1	B1 - 25	25D.C. ...
			1	B2 - 25	
106.1394.XX			4	H - 168	25D.C. ...
			2	B1 - BQ1 - 85	
			2	B2 - BQ2 - 85	
			2	BX1 - 85	
			2	BX2 - 85	
106.1395.XX			2	B1 - BX1 - 158	25D.C. ...
			2	B2 - BX2 - 158	
			2	BQ1 - 70	
			2	BQ2 - 70	
106.1388.XX			2	H - 172	25D.C. ...
			2	H - 178	
106.1390.XX			2	H - 172	25D.C. ...
			2	H - 114	
106.1390.XX			4	H - 172	25D.C. ...
			4	H - 114	
106.0375.--			1	B1 - 218.5	25D.C. ...
			1	B2 - 218.5	
			1	BO1 + BQ1 - 107	
			1	BO2 + BQ2 - 107	

## Outside Corner

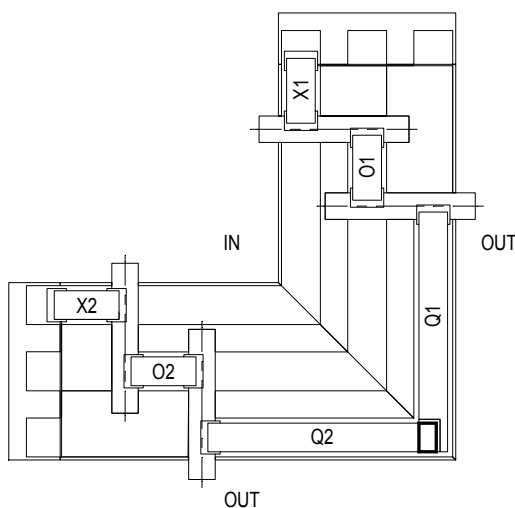

bq1 = BQ1 - 19 *
bo1 = BO1 - 16
bx1 = BX1 - 68
bq2 = BQ2 - 27 - d1*
bo2 = BO2 - 16
bx2 = BX2 - 68
h = H - 152

d1 = thickness outer glass plate  
 \* step glass



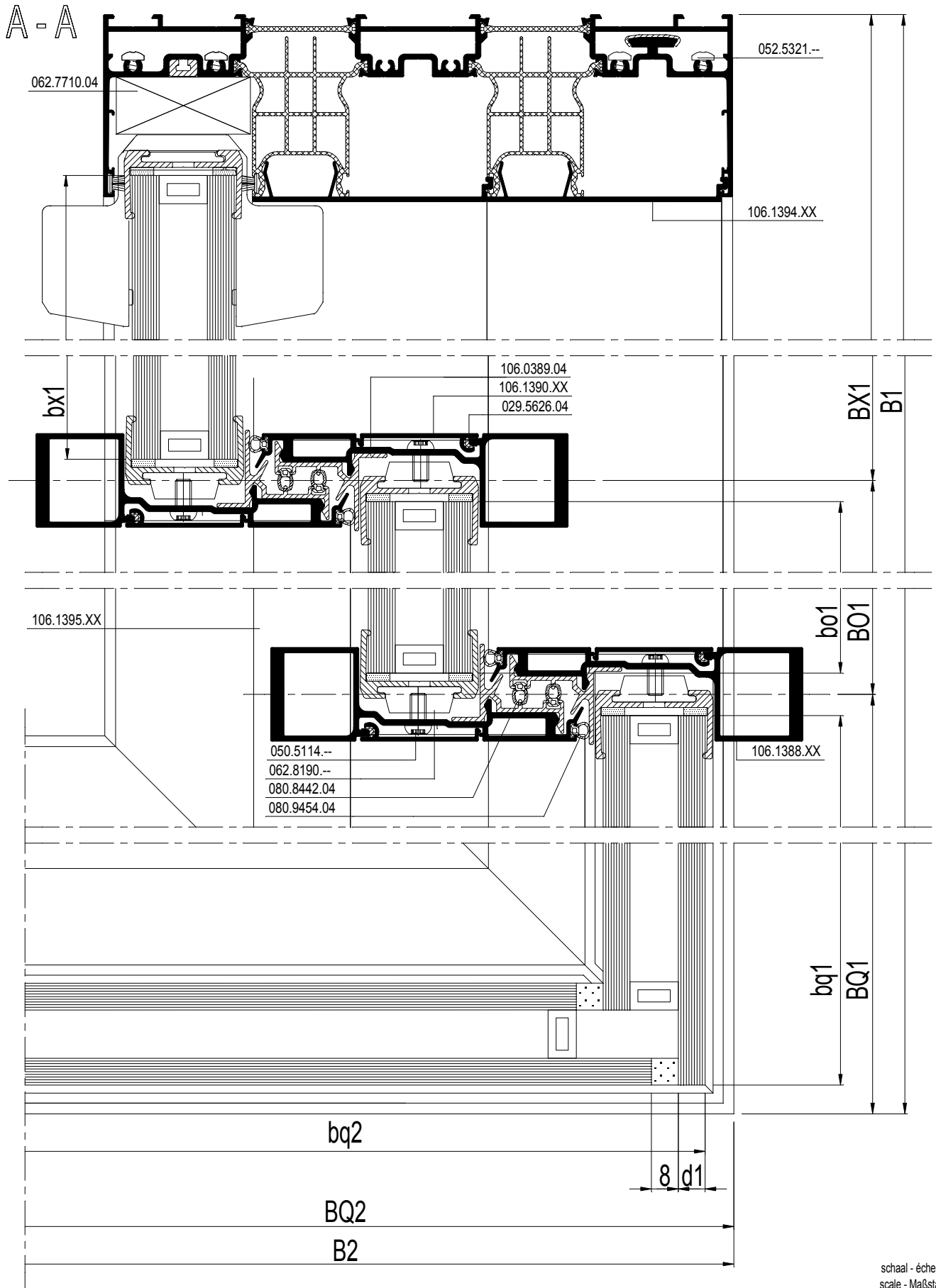

schaal - échelle  
 scale - Maßstab  
 1/2



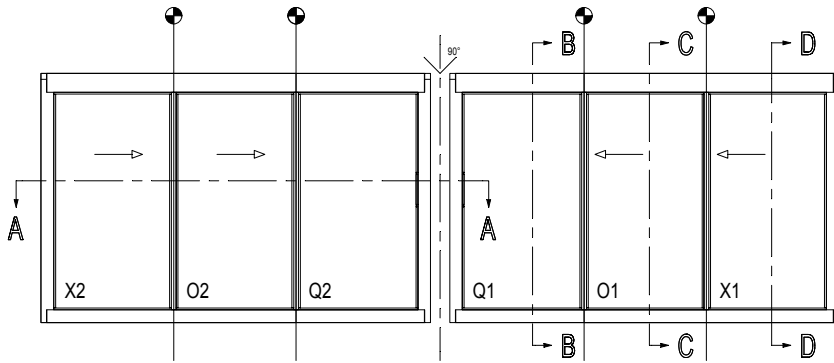



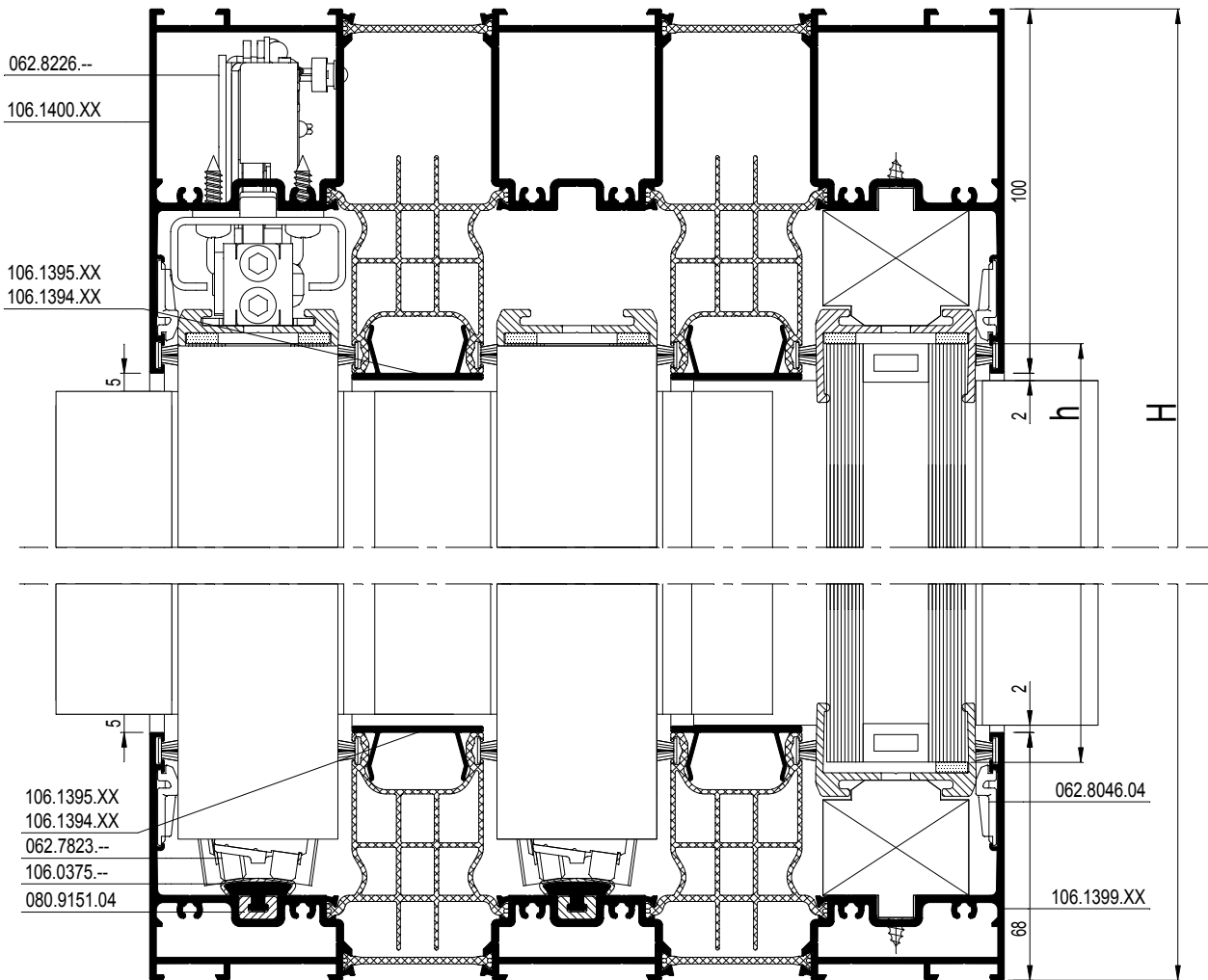



































D2000506



## B - B



schaal - échelle  
 scale - Maßstab  
 1/2  
 D20000507

		#	
062.7775.--		4	25D.G. ...
062.8226.--		2	25D.G. ...
052.5300.--		8	25D.G. ...
080.9151.04		4 x ( B1 + B2 )	25D.G. ...
081.9135.SY		8 x ( B1 + B2 + H )	25D.G. ...
080.8442.04		4 x H	25D.G. ...
080.9454.04		4 x H	25D.G. ...
062.8190.--		5 x ( H/500mm )	25D.G. ...
029.5626.04		4 x H	25D.G. ...
062.7710.04		4	25D.G. ...
052.5300.--		8	25D.G. ...
062.8180.04		25.F ...	25D.G. ...
052.5300.--		25.F ...	25D.G. ...
062.7823.--		8	25D.G. ...
062.9320.04		25.F ...	25D.G. ...
062.9319.04		4	25D.G. ...
052.5321.--		24	ACCESS CS
062.8046.04		25.F ...	25D.G. ...
062.8176.04		2	25D.G. ...
062.8182.--		2	25D.G. ...
052.5300.--		8	25D.G. ...
062.8081.04		8	25D.G. ...
080.9150.04		2 x H	25D.G. ...
052.5343.--		1 x ( H/300mm )	25D.G. ...
062.8087.--		2	25D.G. ...
062.8088.--		2	25D.G. ...
062.9425.--		4	25D.G. ...
062.9426.--		4	25D.G. ...
062.9427.--		2	25D.G. ...
062.9428.--		2	25D.G. ...
062.9429.--		2	25D.G. ...
054.5441.04		32	25D.G. ...
050.5094.--		32	25D.G. ...
069.6830.XX		min. 4	25D.G. ...
069.6831.XX		25.F ...	25D.G. ...
084.9114.04		8 x H	25D.G. ...
062.8160.XX		12	25D.G. ...
050.5050.--		4	25D.G. ...
062.8161.XX		4	25D.G. ...
052.5333.--		8	25D.G. ...

## Inside Corner

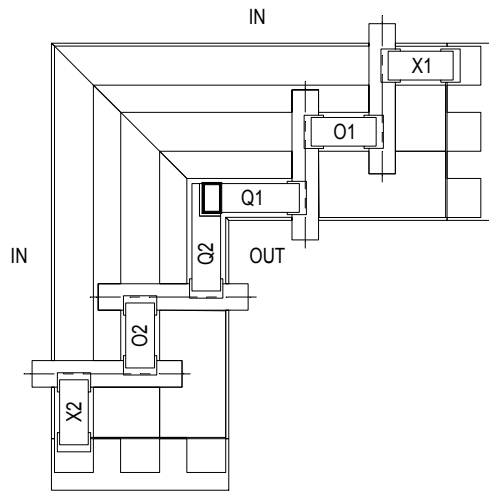

$bq1 = BQ1 - 114.5 - d1^*$
$bo1 = B01 - 16$
$bx1 = BX1 - 68$
$bq2 = BQ2 - 106.5^*$
$bo2 = B02 - 16$
$bx2 = BX2 - 68$
$h = H - 152$

## Outside Corner

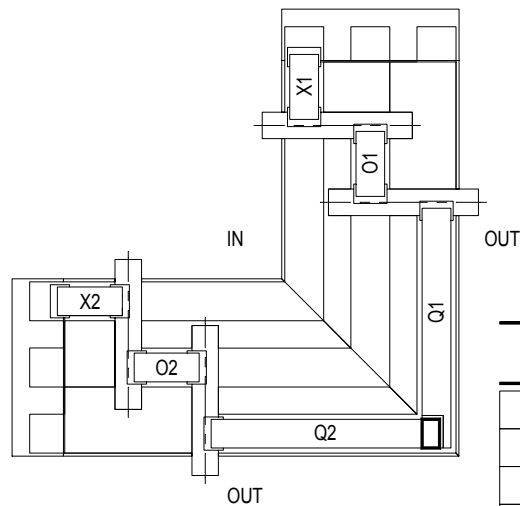



$bq1 = BQ1 - 19^*$
$bo1 = B01 - 16$
$bx1 = BX1 - 68$
$bq2 = BQ2 - 27 - d1^*$
$bo2 = B02 - 16$
$bx2 = BX2 - 68$
$h = H - 152$

d1 = thickness outer glass plate

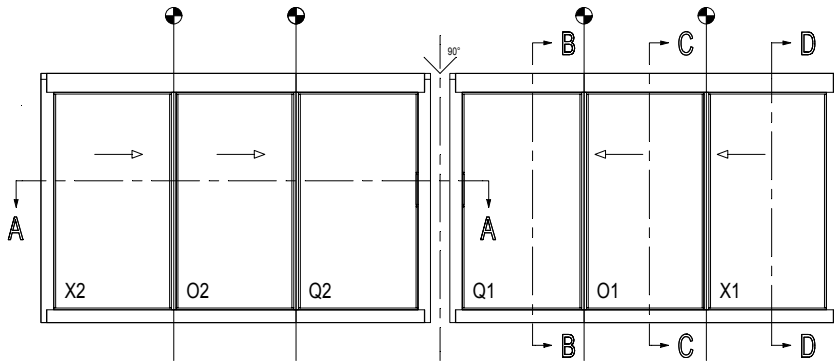
\* step glass

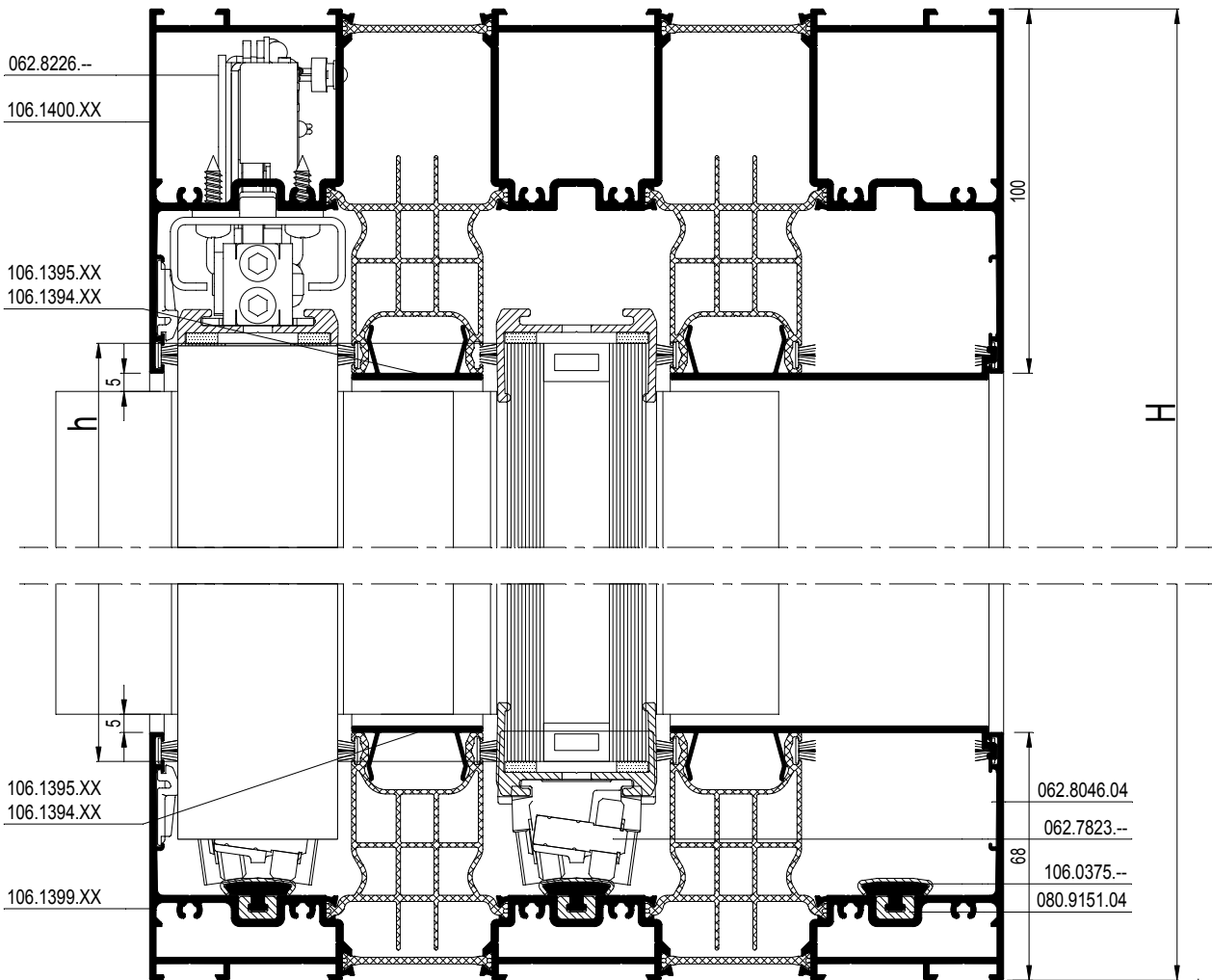

## C - C



schaal - échelle  
 scale - Maßstab  
 1/2  
 D20000508

## Outside Corner

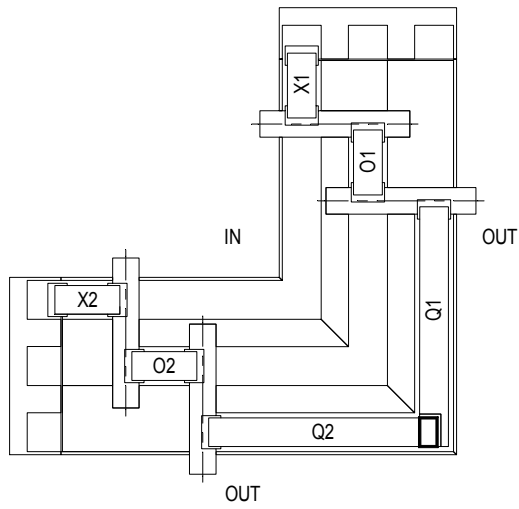

## Inside Corner

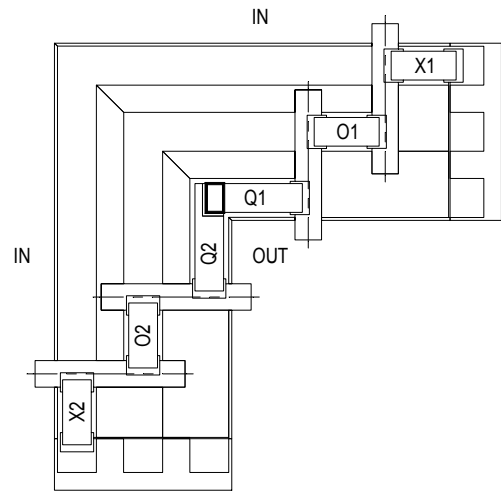

## D - D

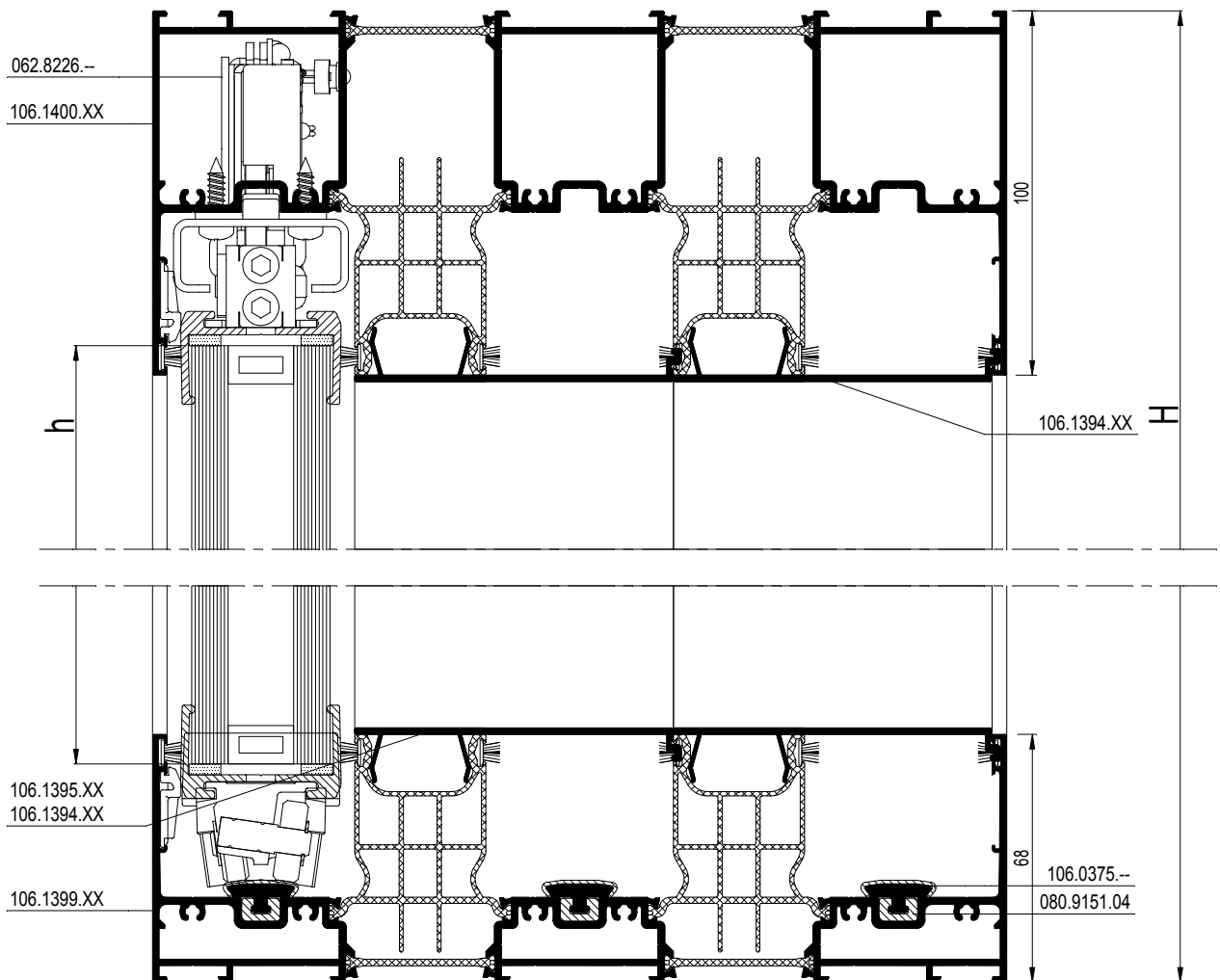

schaal - échelle  
 scale - Maßstab  
 1/2

D2000508



**F**



Montagetekeningen  
Fabrication et montage  
Assembly drawings  
Montagezeichnungen







**1** KEUZE CONFIGURATIE  
 CHOIX DE CONFIGURATION  
 CONFIGURATION SELECT  
 WAHL KONFIGURATION

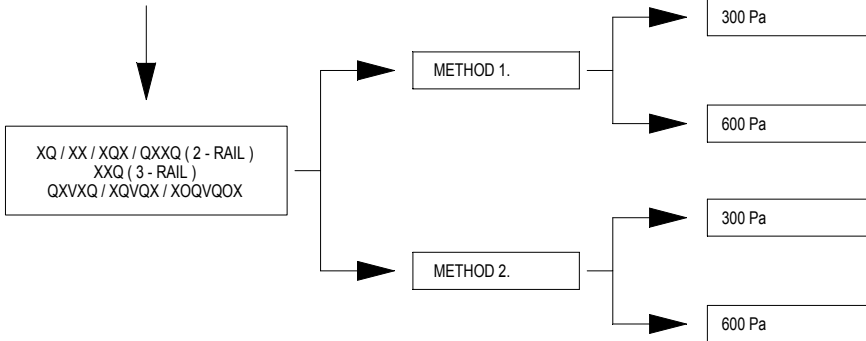

**2** ZAGEN  
 SCIER  
 SAWING  
 SAEGEN

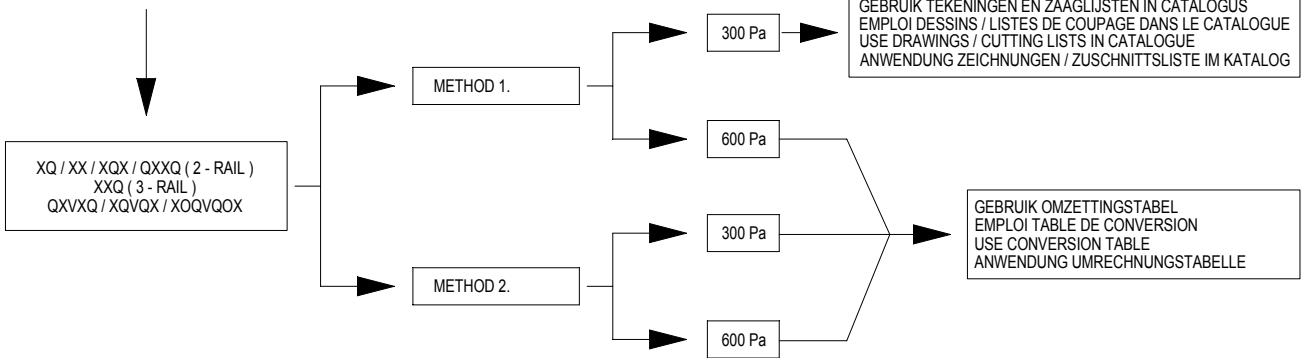

**3** FREZEN  
 FRAISE  
 MILLING  
 FRAESE

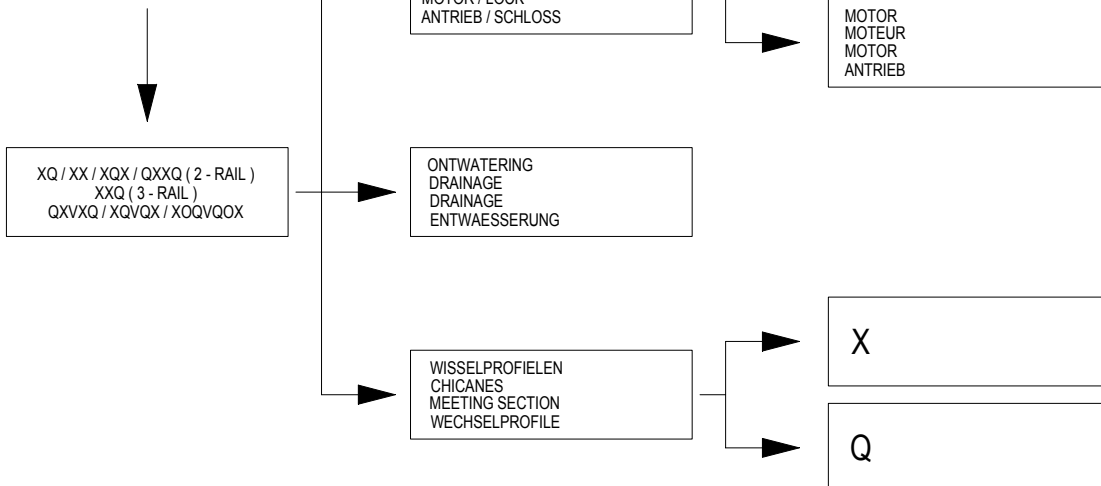

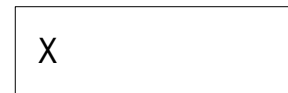
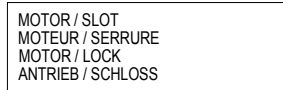
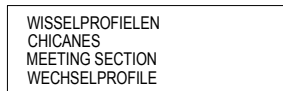
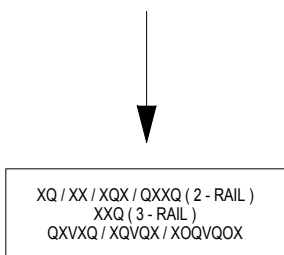
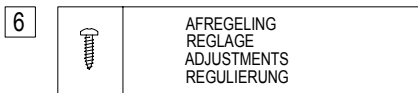
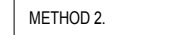
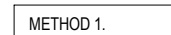
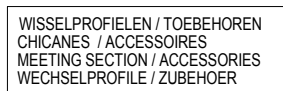
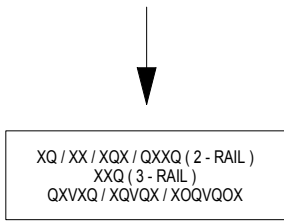
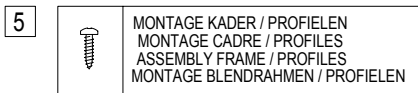
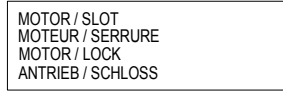
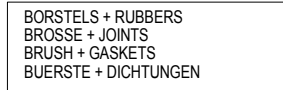
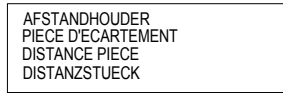
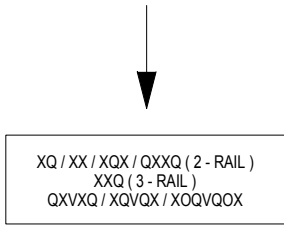
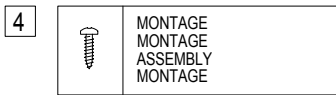

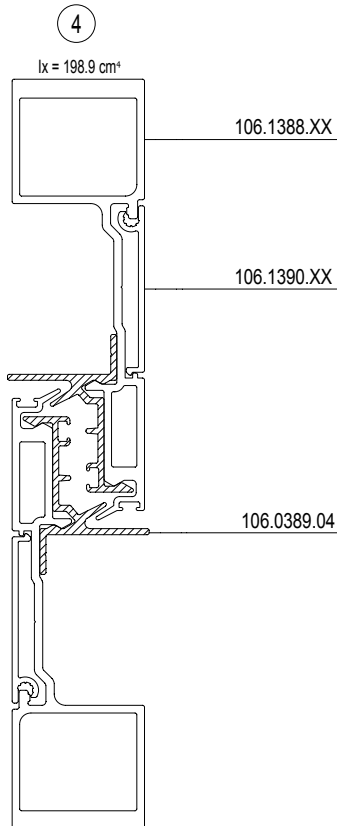
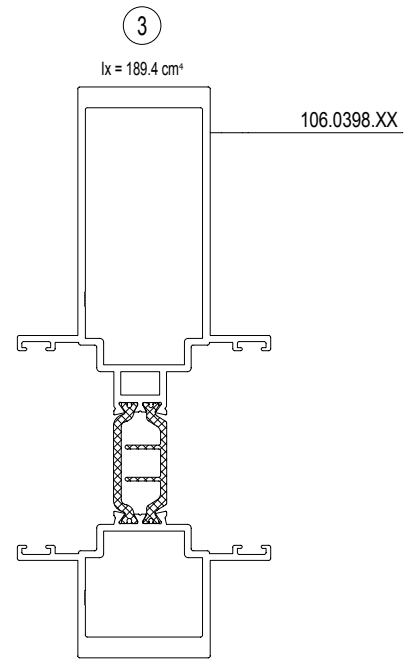
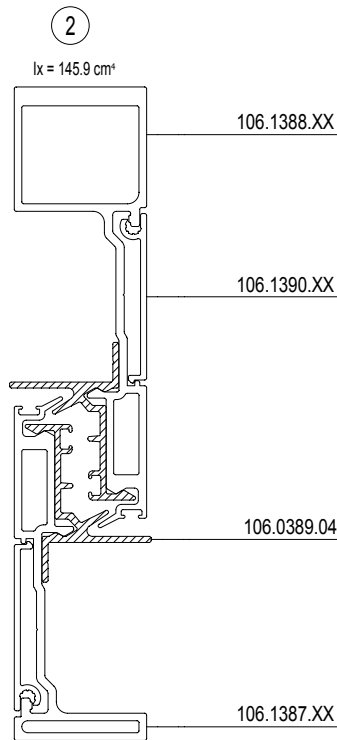
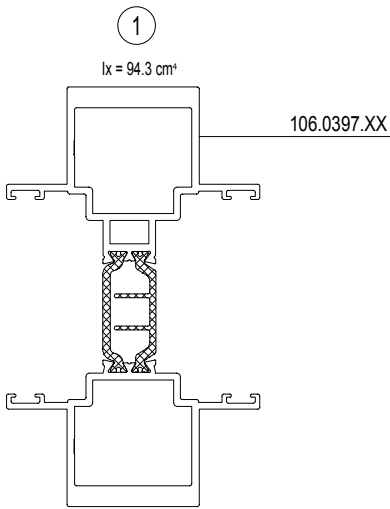
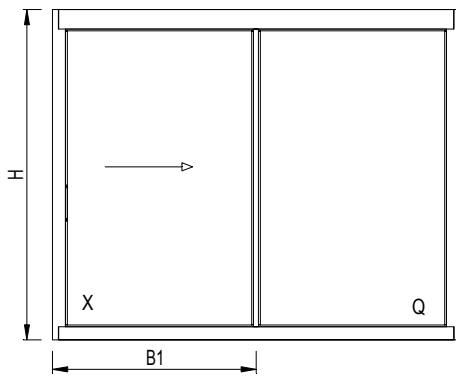

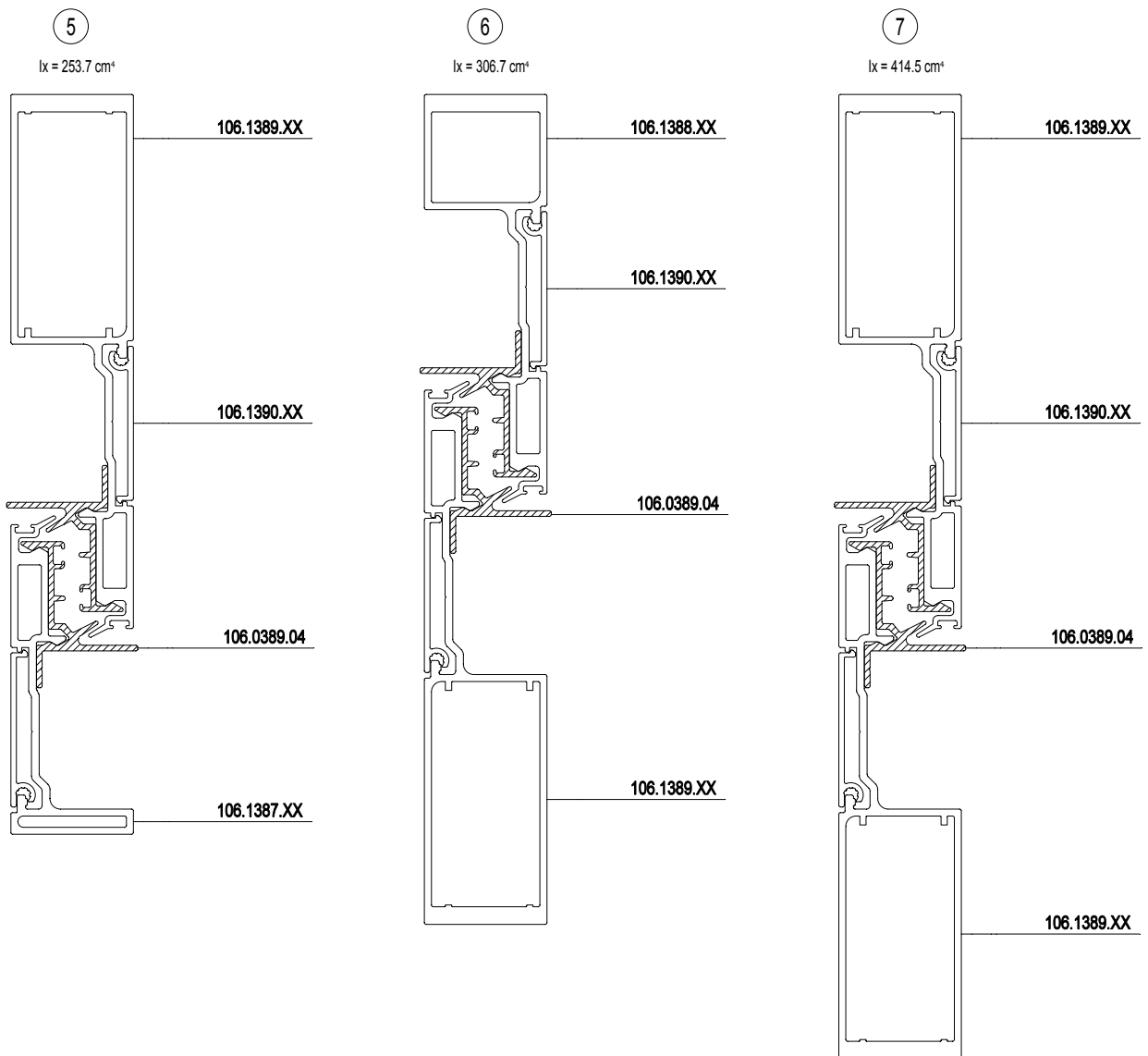

**P = 400 Pa**

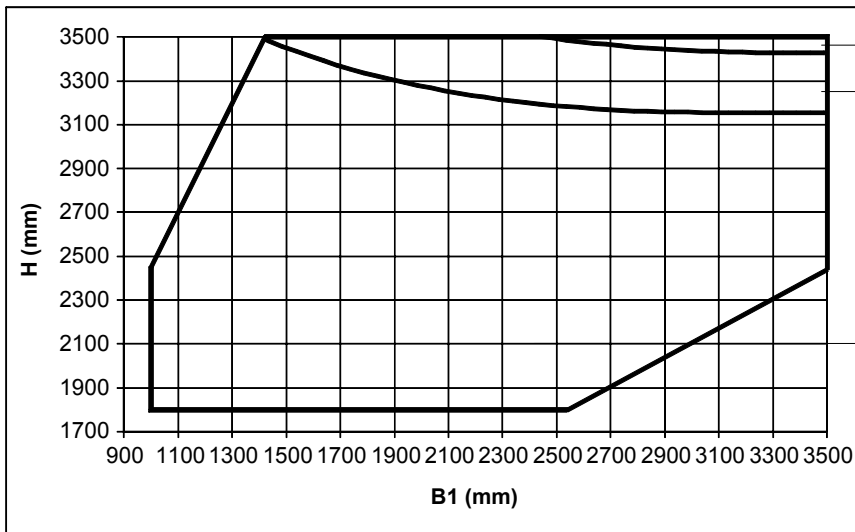

**f max. = H / 150  
 max. 12mm**

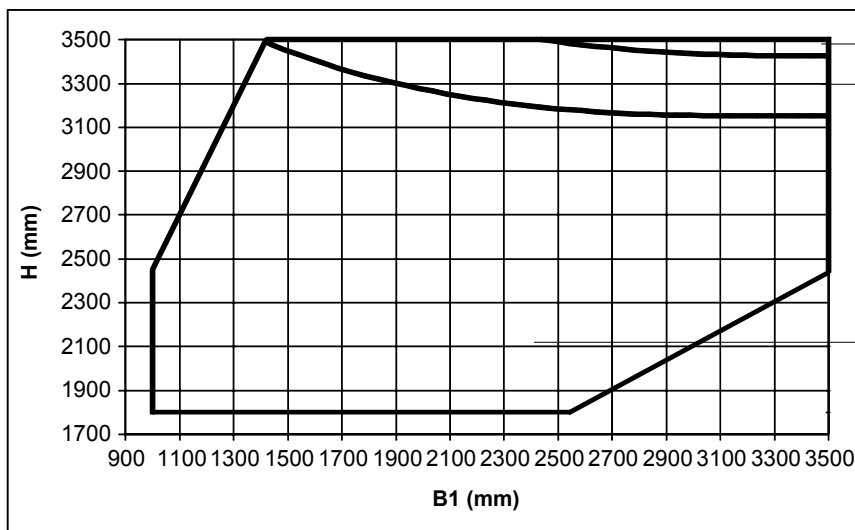

**f max. = H / 200  
 max. 12mm**

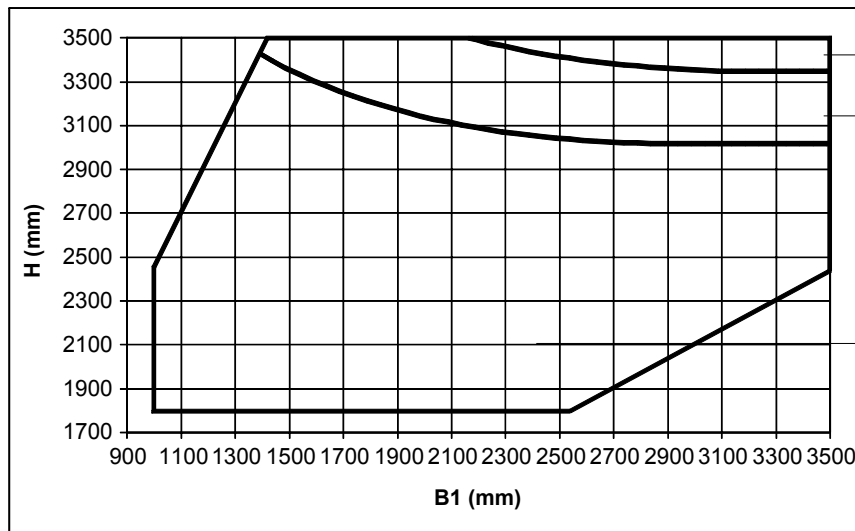

**f max. = H / 300  
 max. 12mm**

## P = 600 Pa

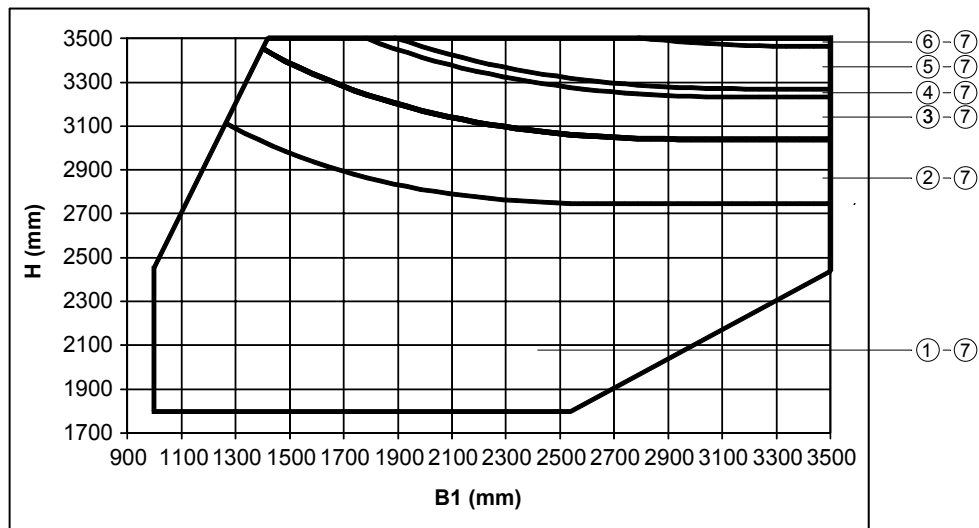
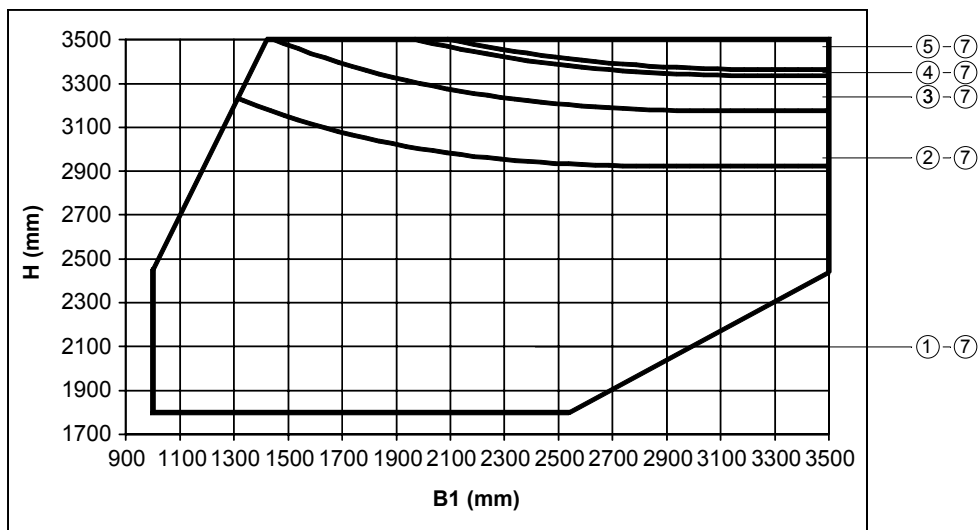
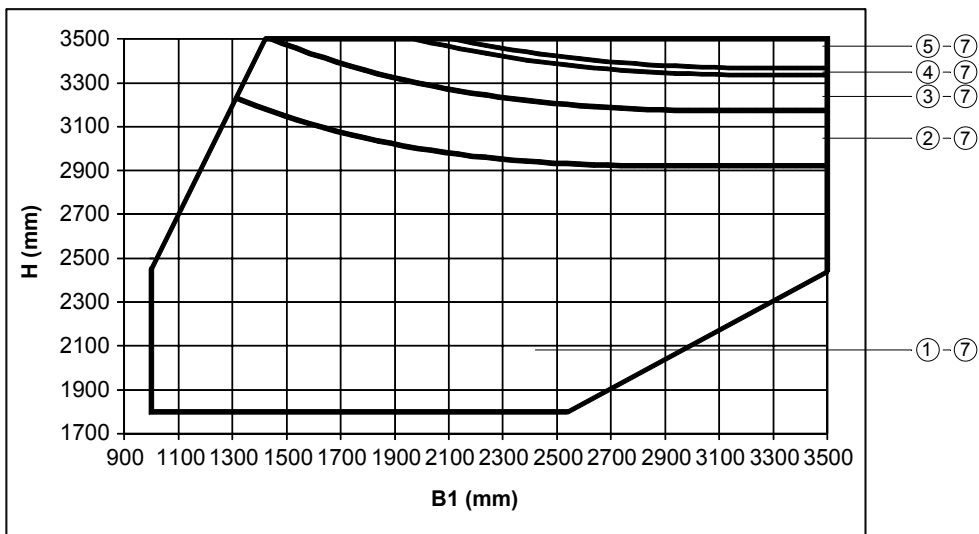

**P = 800 Pa**

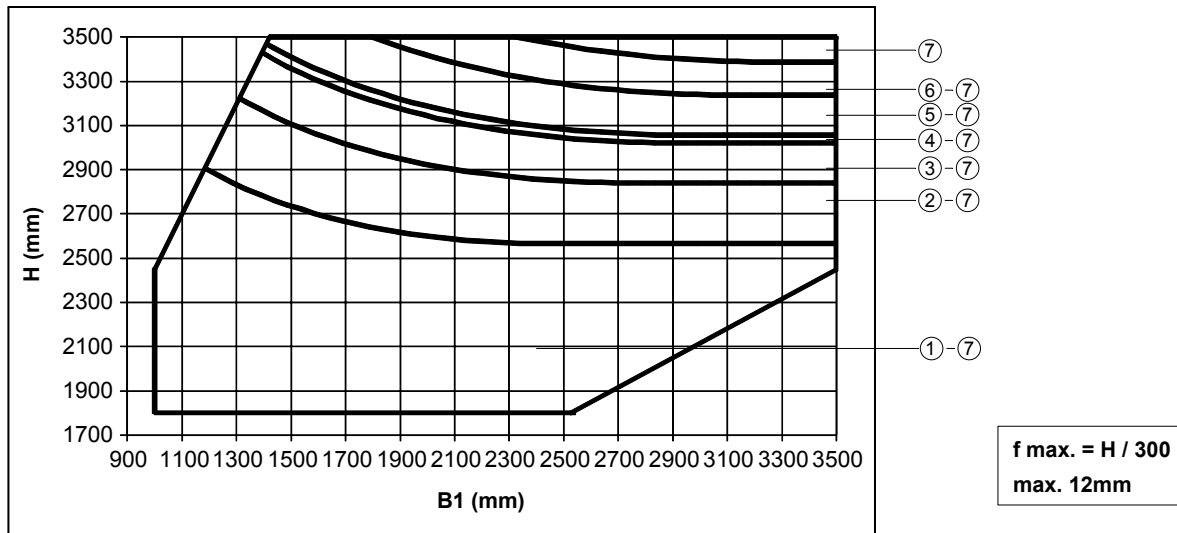
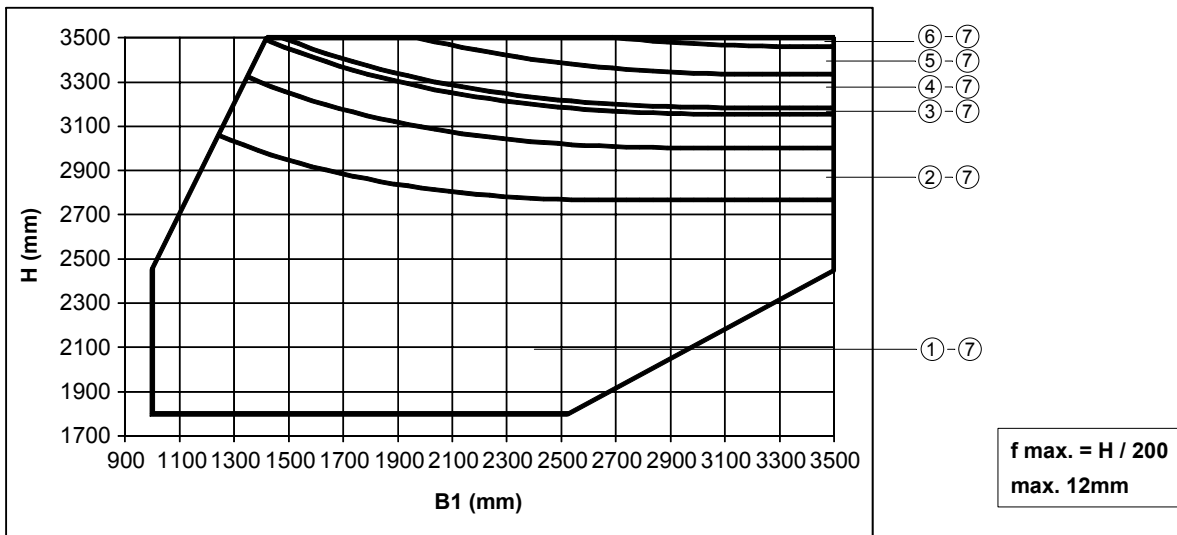
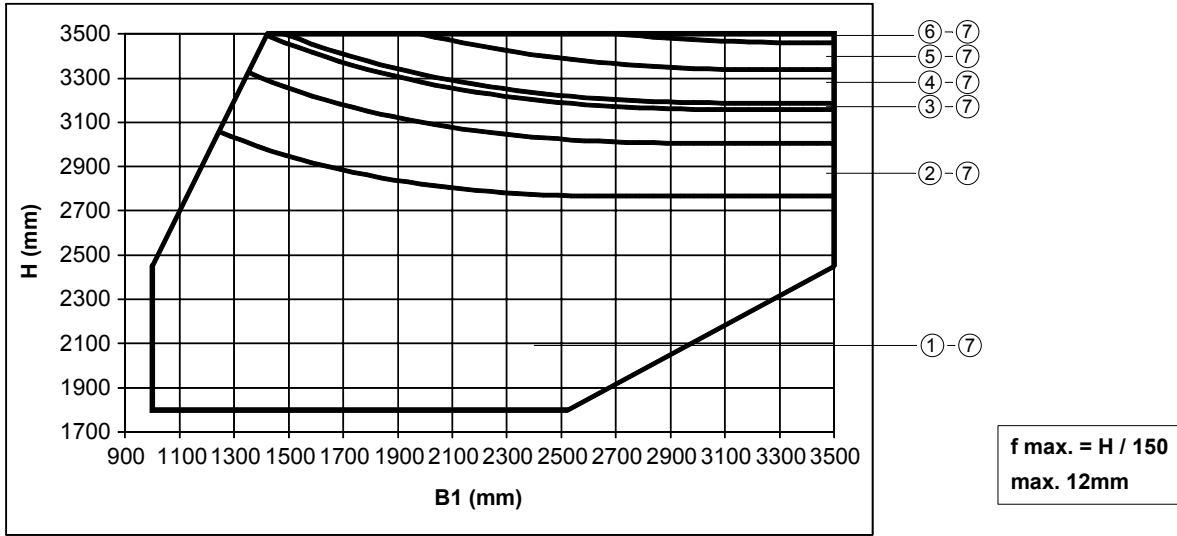



**P = 1000 Pa**

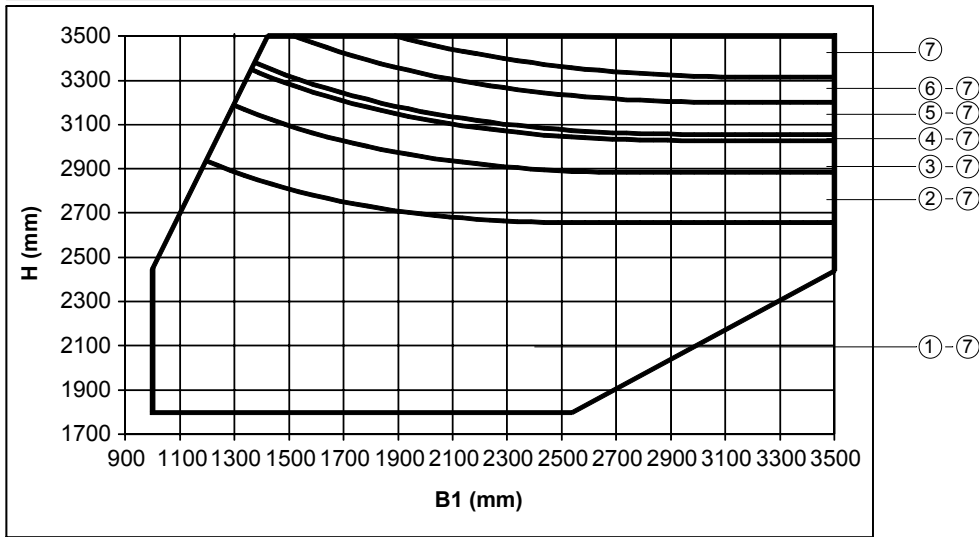

**f max. = H / 150  
 max. 12mm**

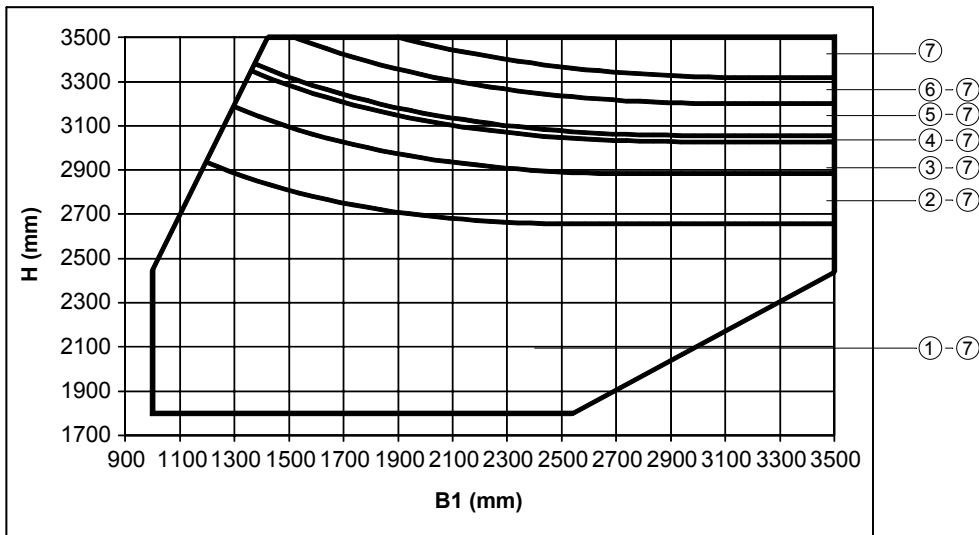

**f max. = H / 200  
 max. 12mm**

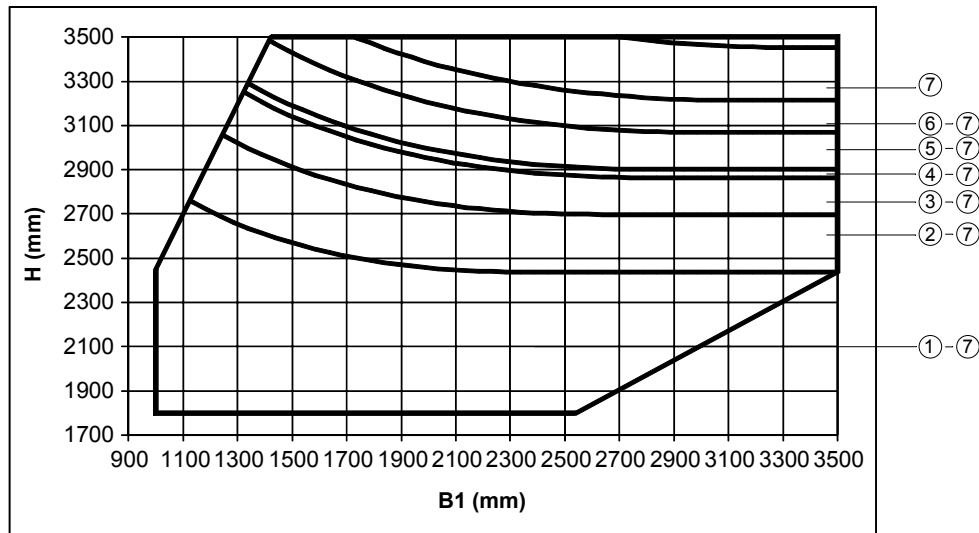

**f max. = H / 300  
 max. 12mm**

## P = 1200 Pa

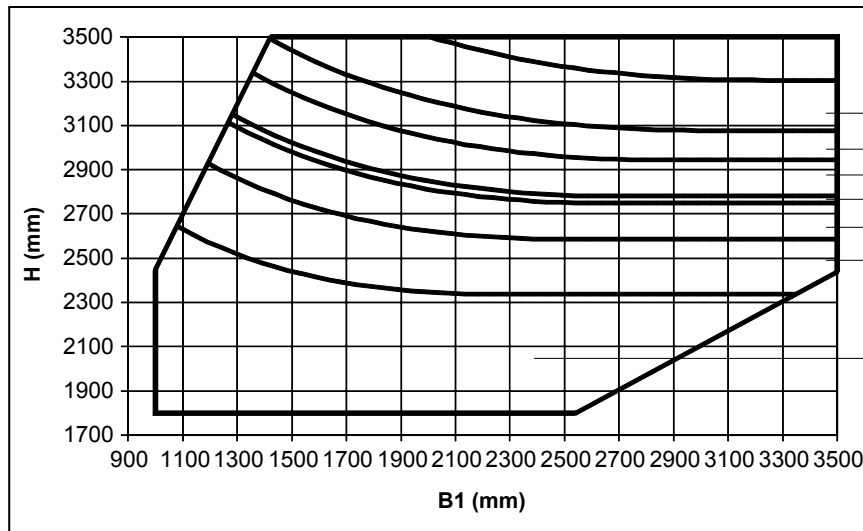
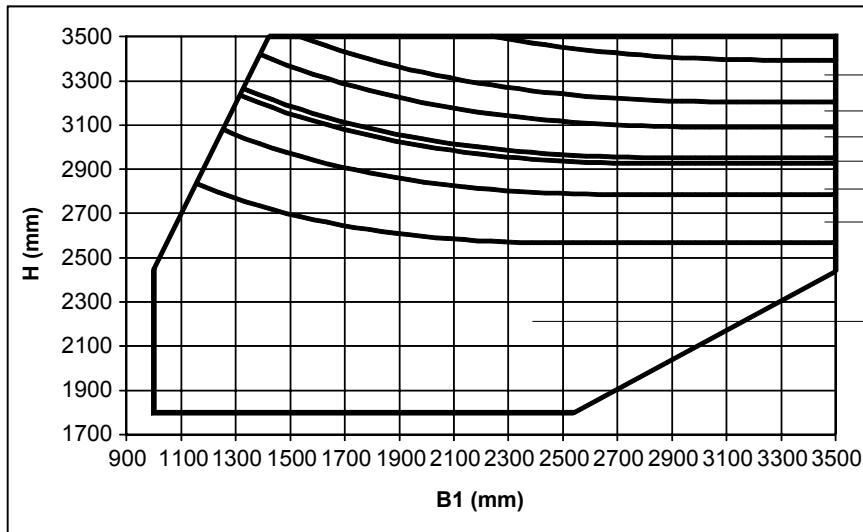
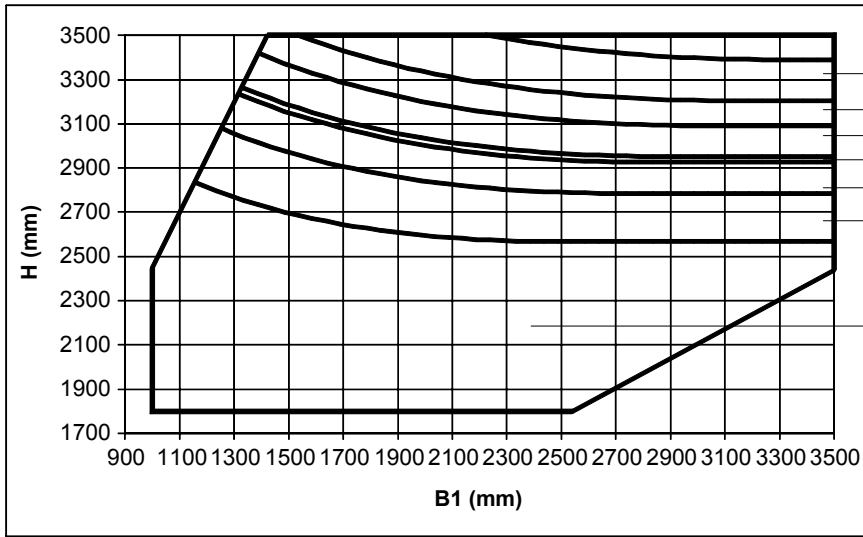

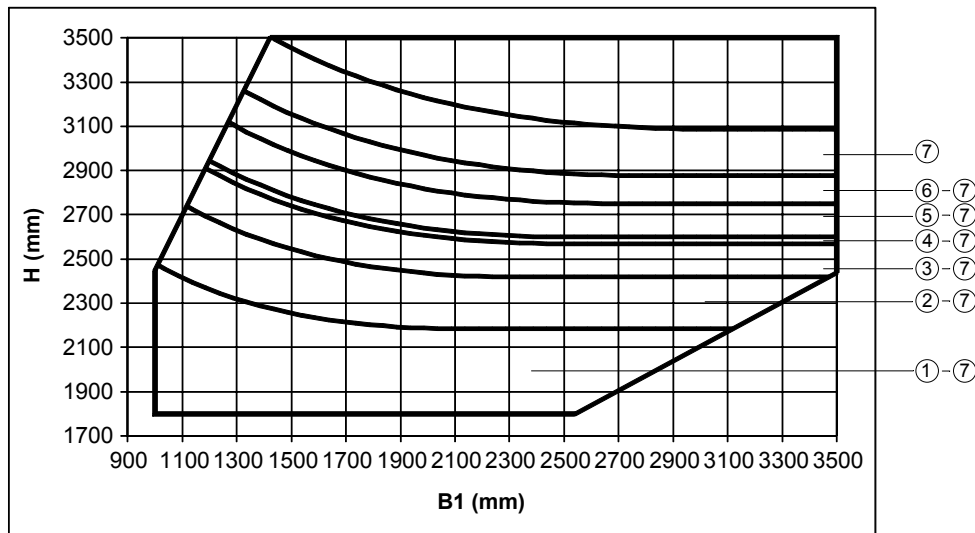
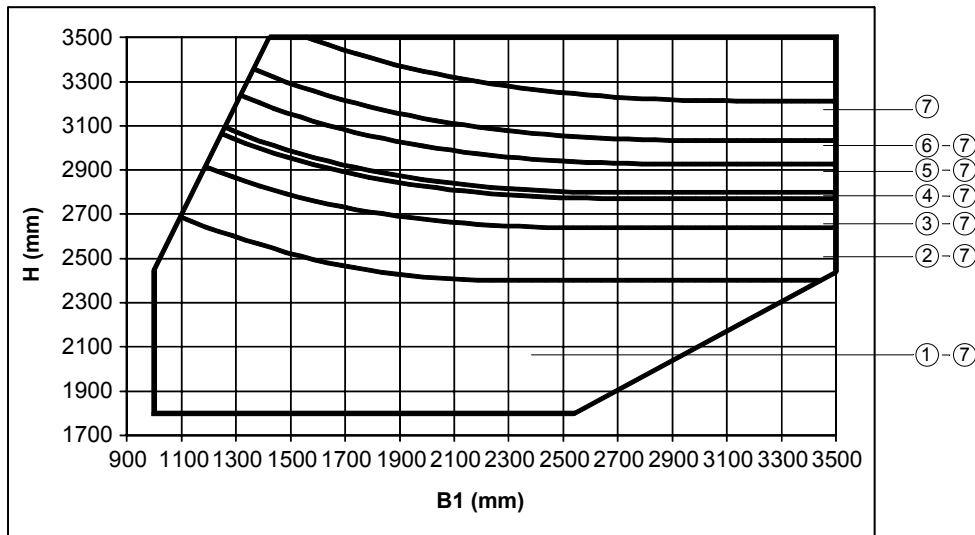
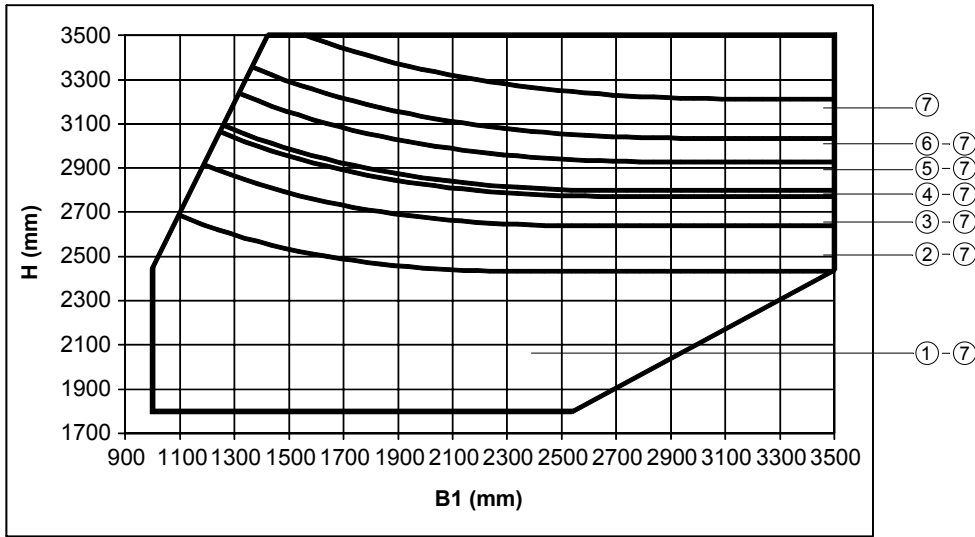

**P = 1600 Pa**

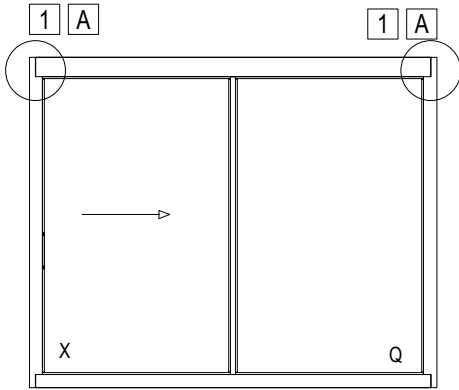



1 A

	097.0102.00 (Ø5)
of / ou / or / oder	
	095.C300.00
of / ou / or / oder	
	095.N000.00

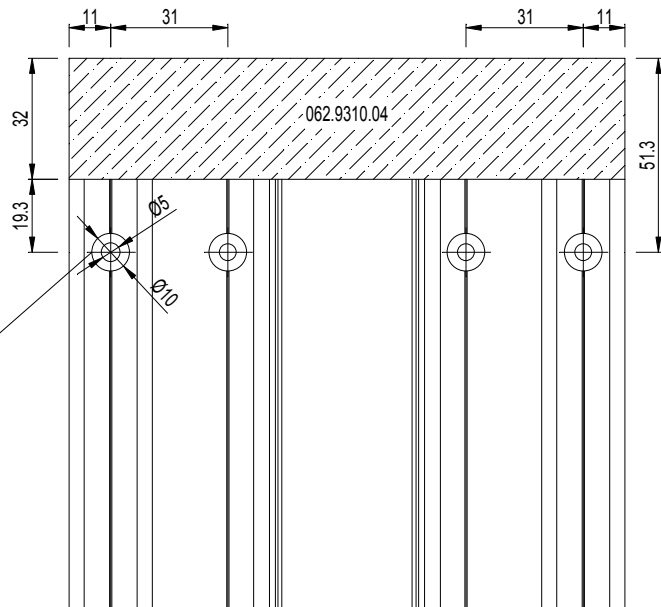



METHODE 1.  
 METHODE 1.  
 METHOD 1.  
 METHODE 1.

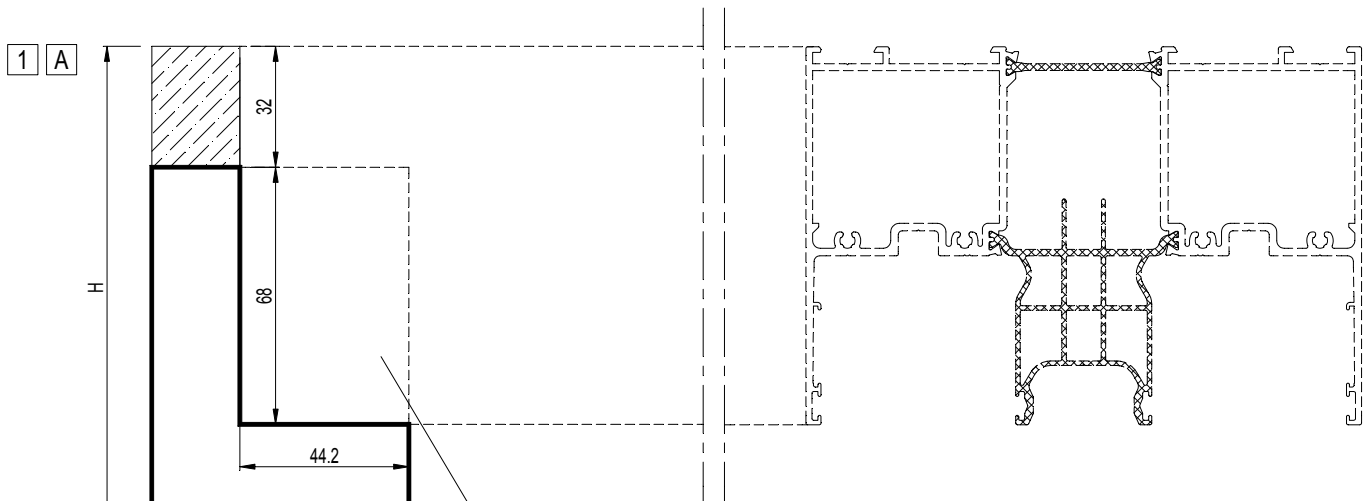
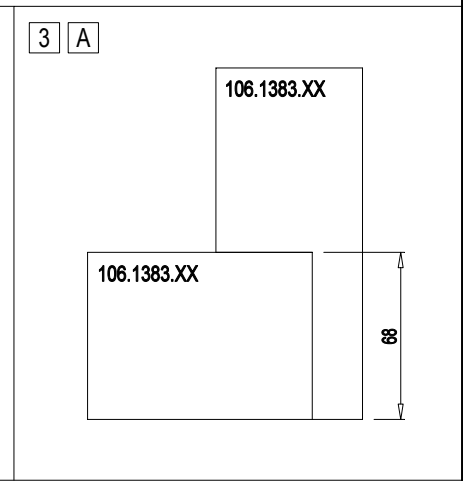
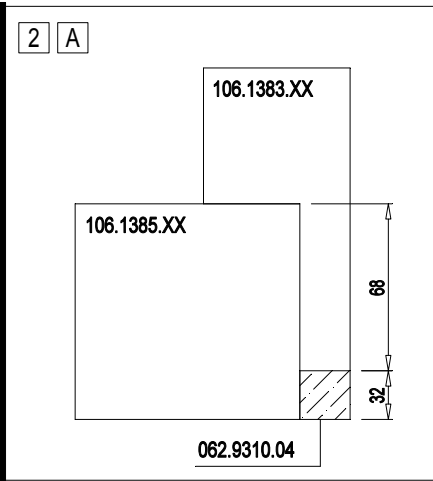
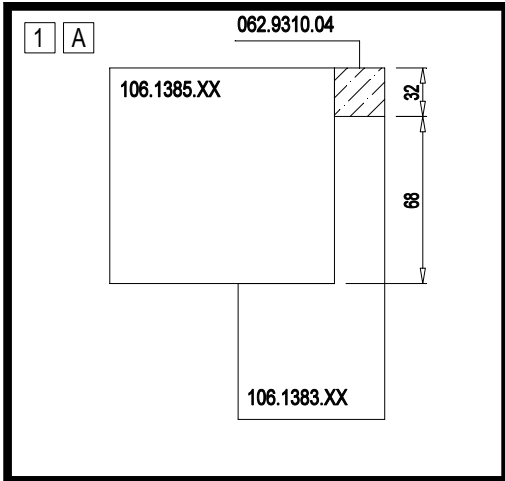

- |                     |             |
|---------------------|-------------|
|                     | 095.AKF6.00 |
| of / ou / or / oder |             |
|                     | 095.D300.00 |
| of / ou / or / oder |             |
|                     | 095.N000.00 |

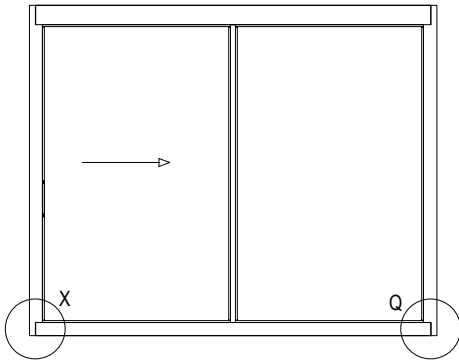

2 A  
3 A

2 A  
3 A

	097.0102.00 (Ø5)
of / ou / or / oder	
	095.C300.00
of / ou / or / oder	
	095.N000.00

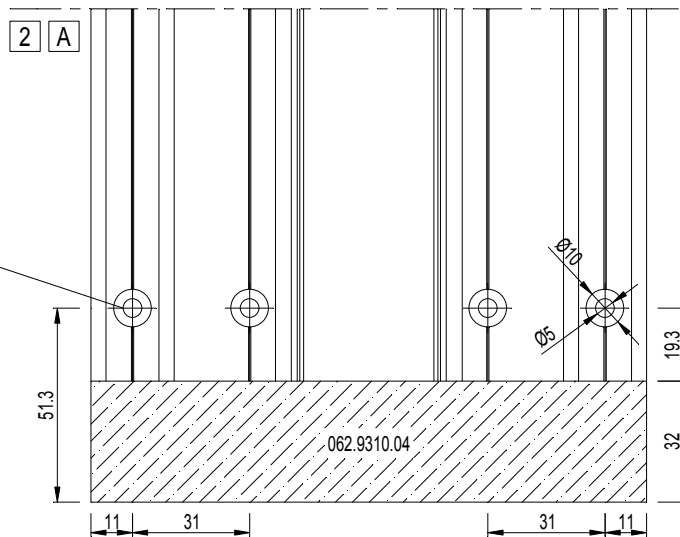

	097.0102.00 (Ø5)
of / ou / or / oder	
	095.C300.00
of / ou / or / oder	
	095.N000.00

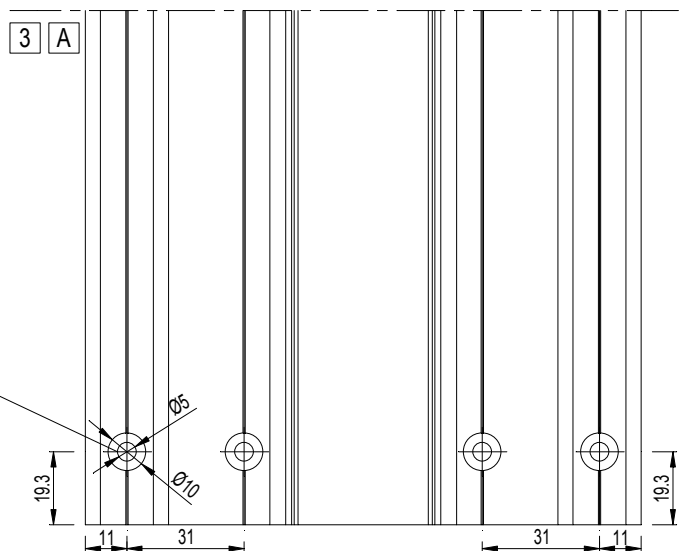



METHODE 1.  
 METHODE 1.  
 METHOD 1.  
 METHODE 1.

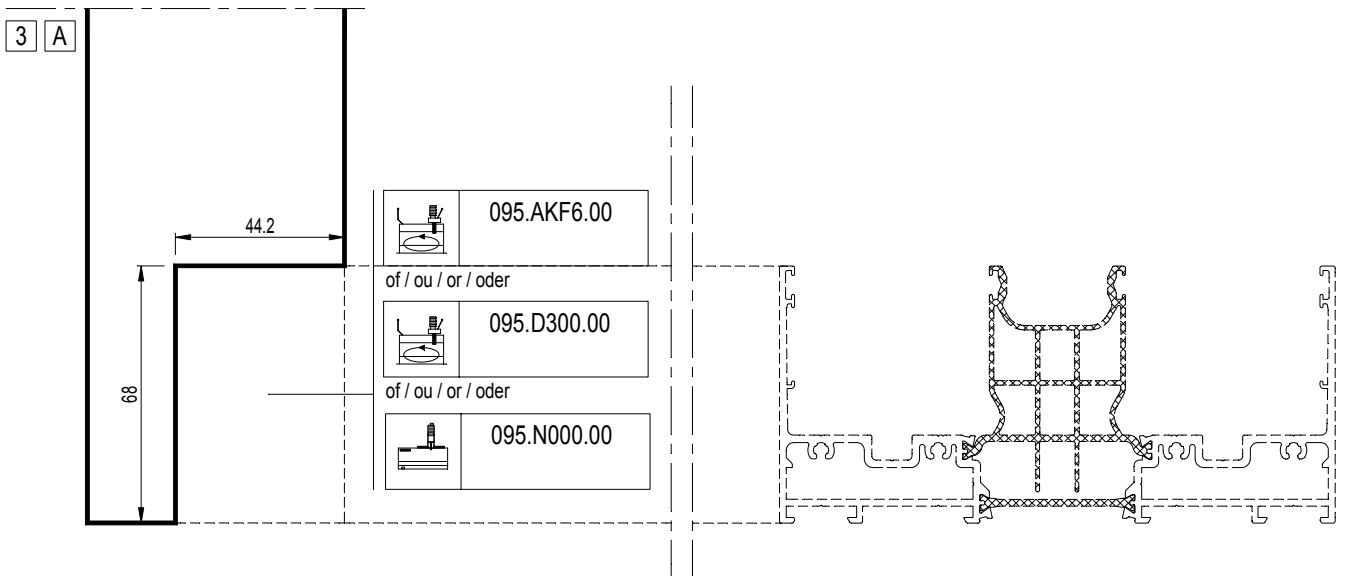
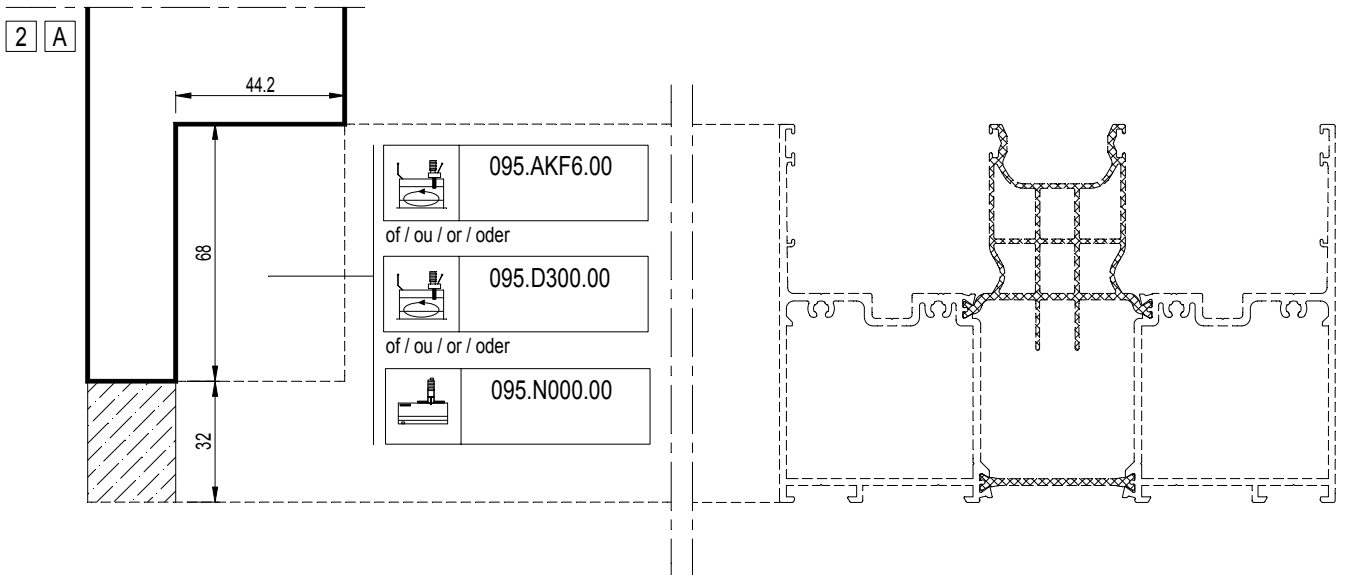
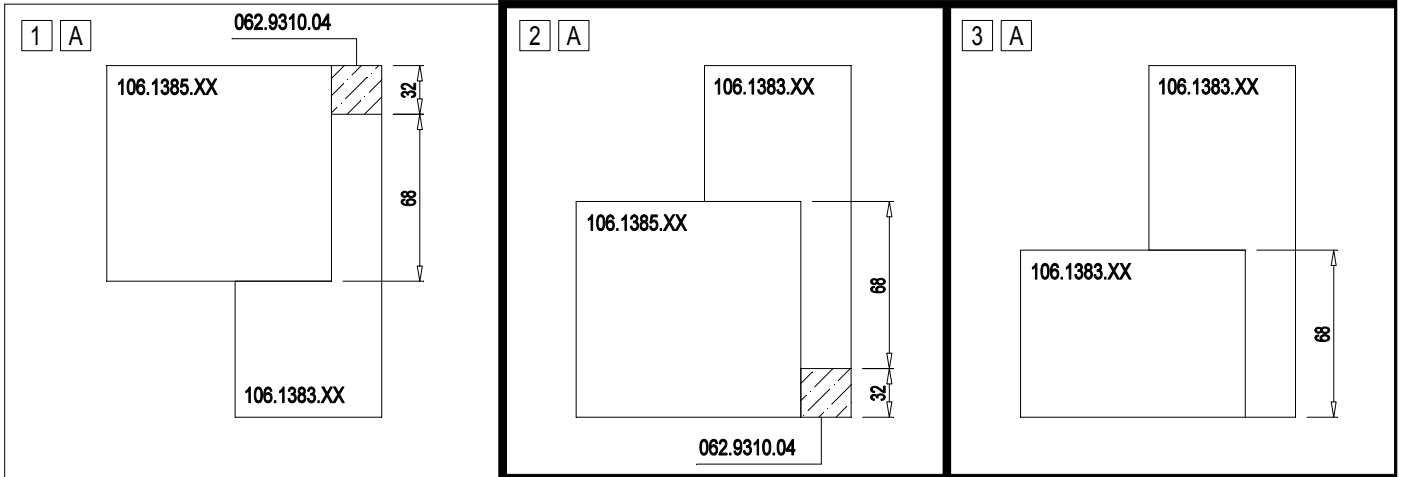

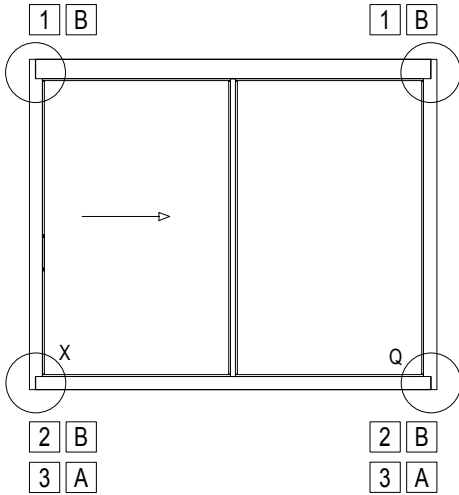

	097.0102.00 (Ø5)
of / ou / or / oder	
	095.C300.00
of / ou / or / oder	
	095.N000.00

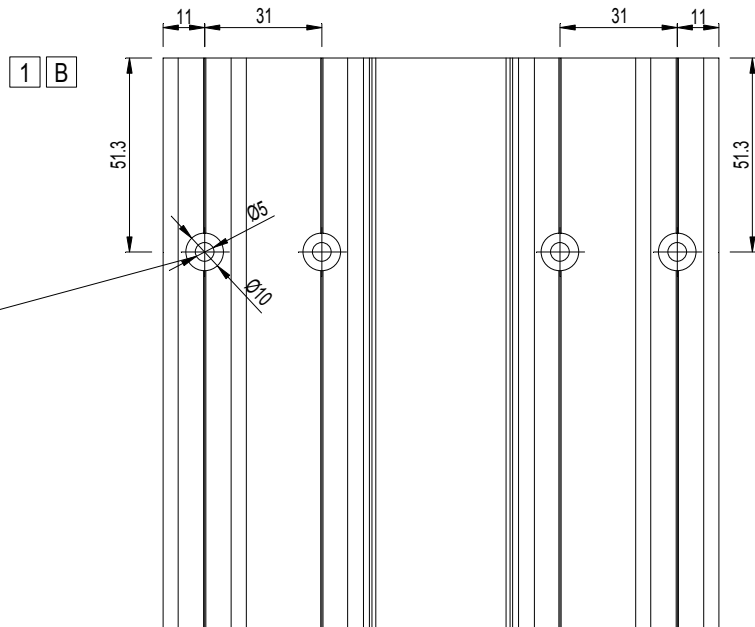

	097.0102.00 (Ø5)
of / ou / or / oder	
	095.C300.00
of / ou / or / oder	
	095.N000.00

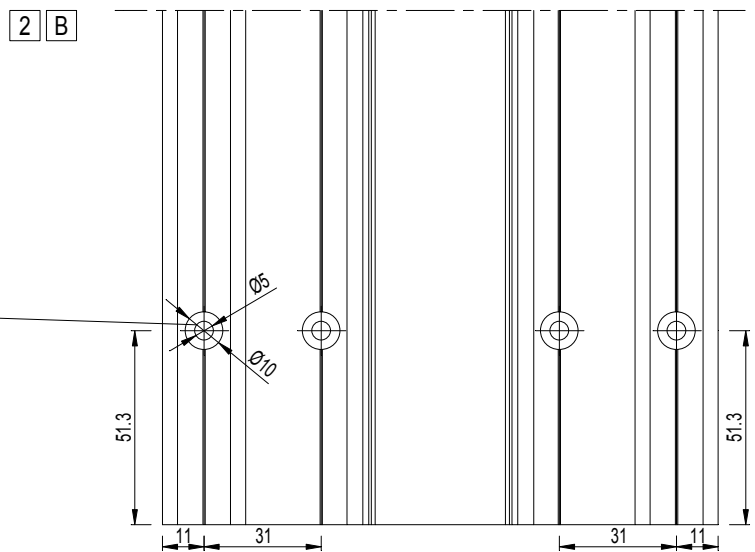





METHODE 2.  
 METHODE 2.  
 METHOD 2.  
 METHODE 2.

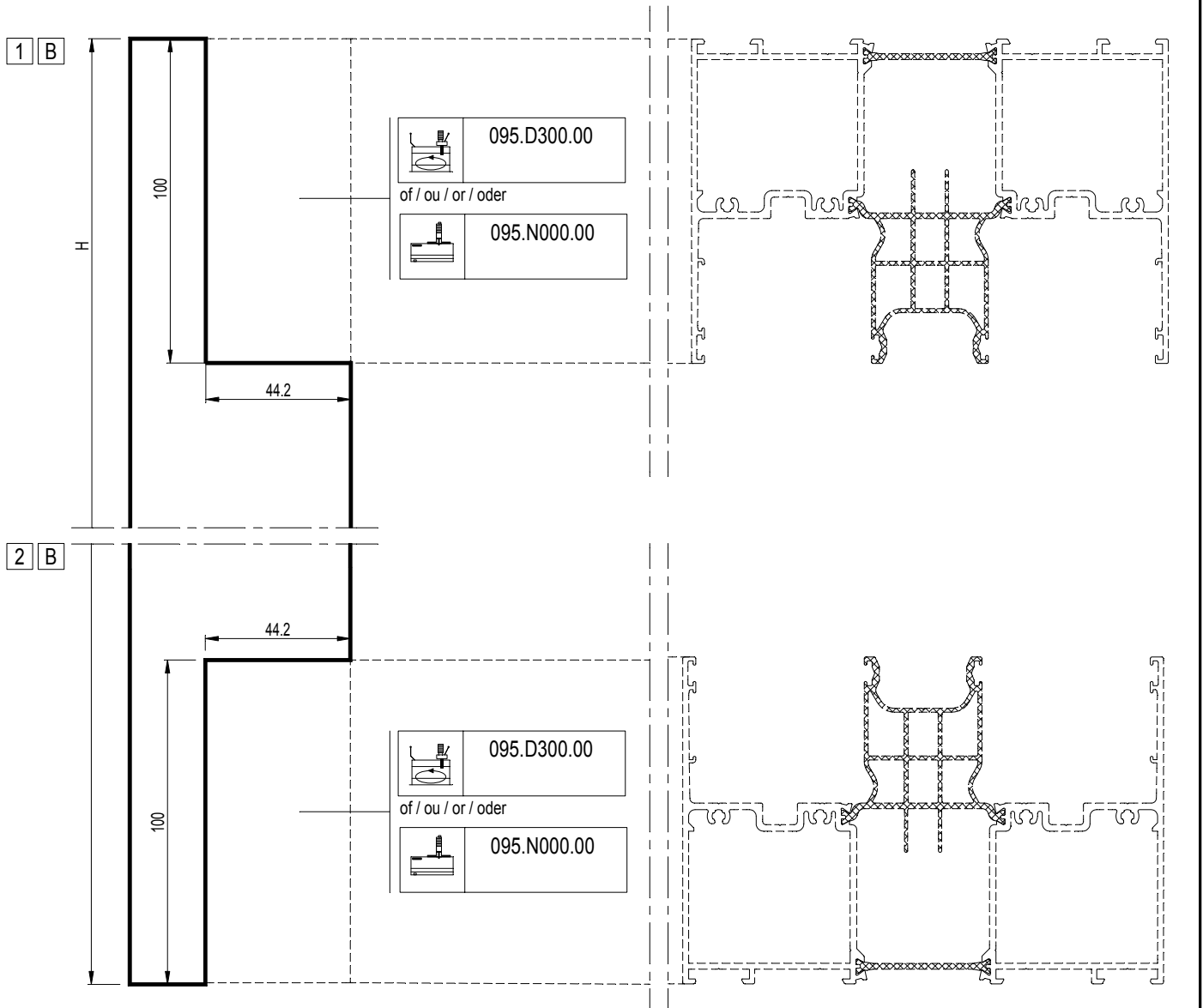
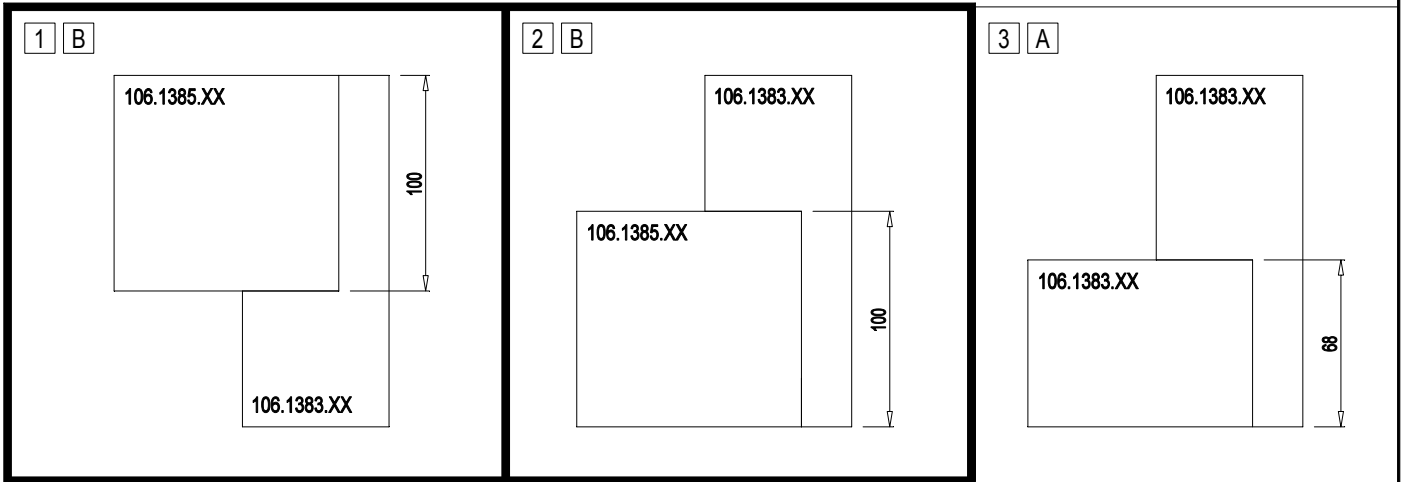

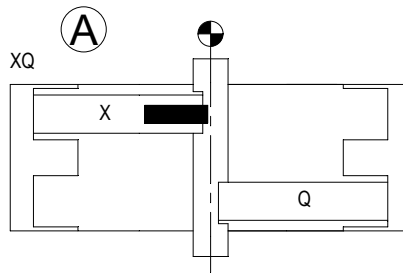
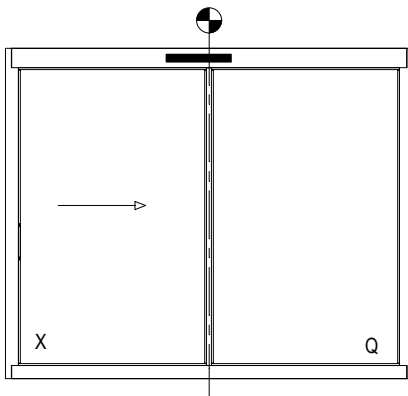

XQX

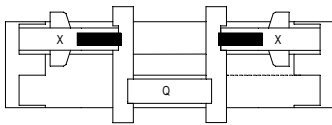

QXXQ

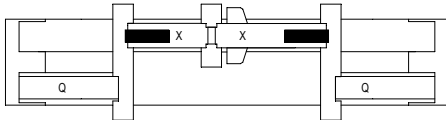

XOQ

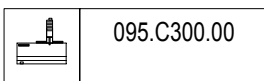
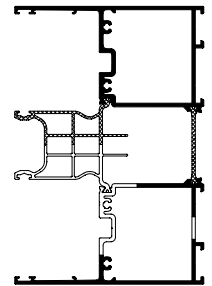
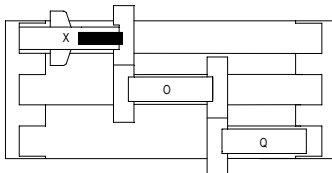

of / ou / or / oder

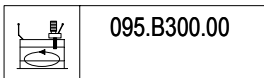

of / ou / or / oder

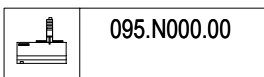

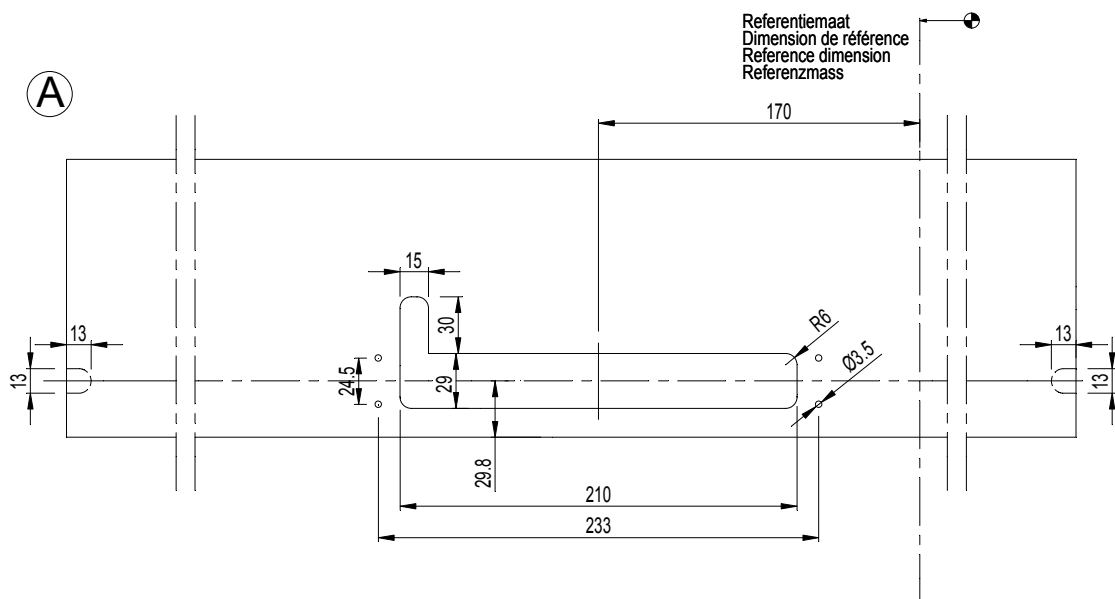

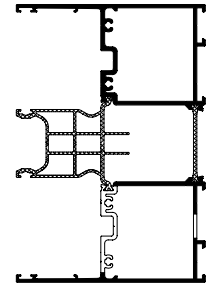
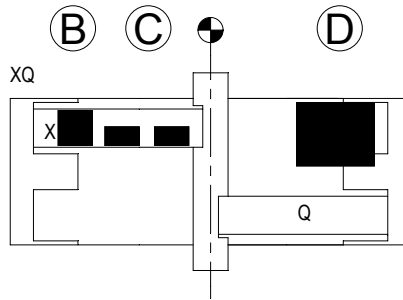
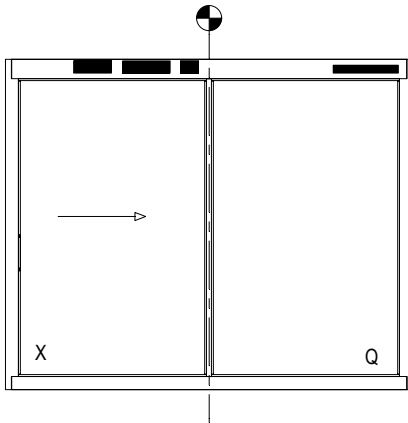

XQX

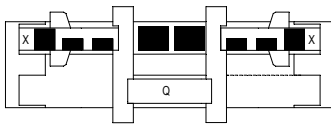

QXXQ

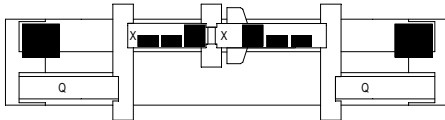

XOQ

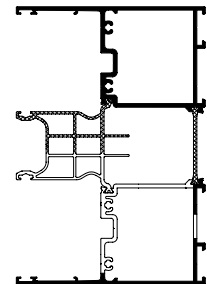
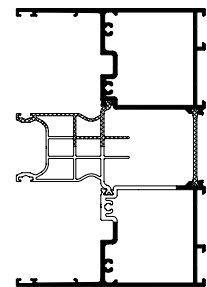
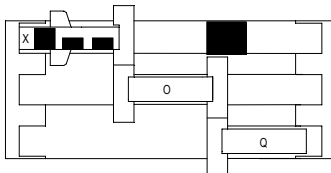

	095.C300.00
of / ou / or / oder	
	095.N000.00

+

	095.C321.00
--	-------------

MONTAGEVOLGORDE L'ORDRE DE MONTAGE THE ORDER OF ASSEMBLY MONTAGEREIHENFOLGE	1	2	3	.
--	---	---	---	---

(B)

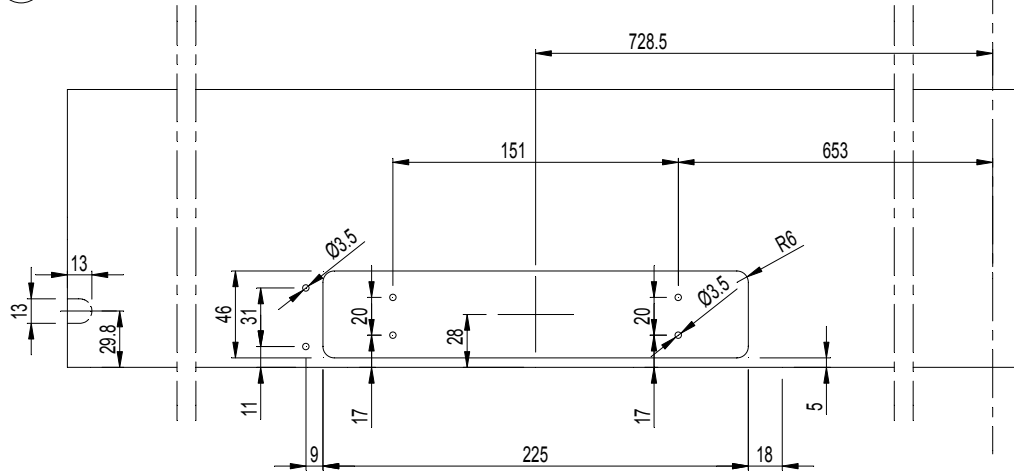

(C)

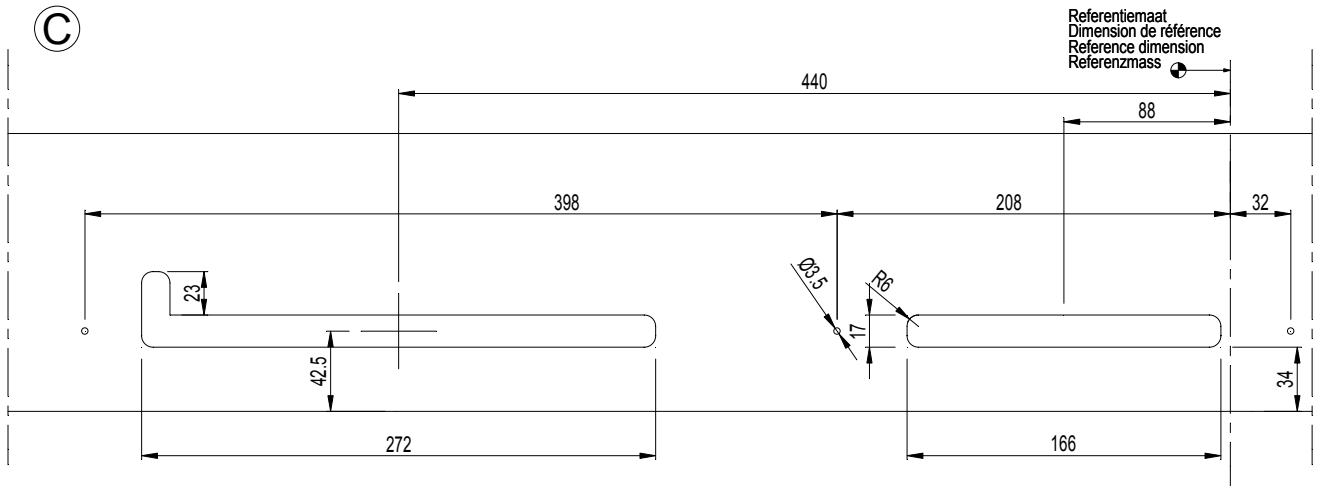

(D)

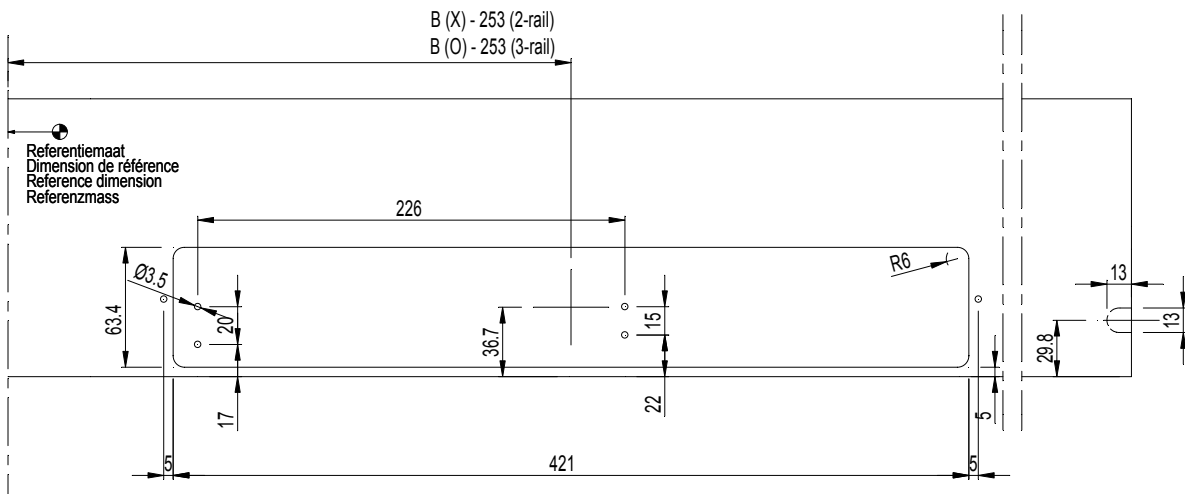

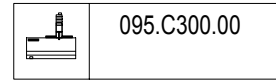
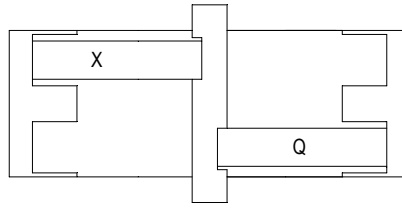
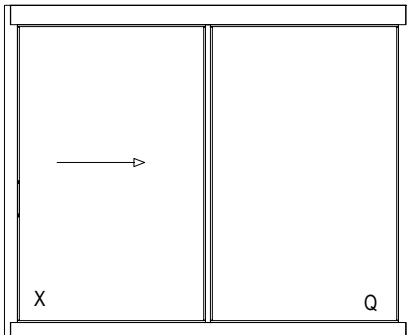

of / ou / or / oder

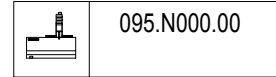

of / ou / or / oder

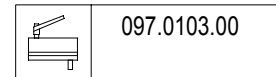

View X

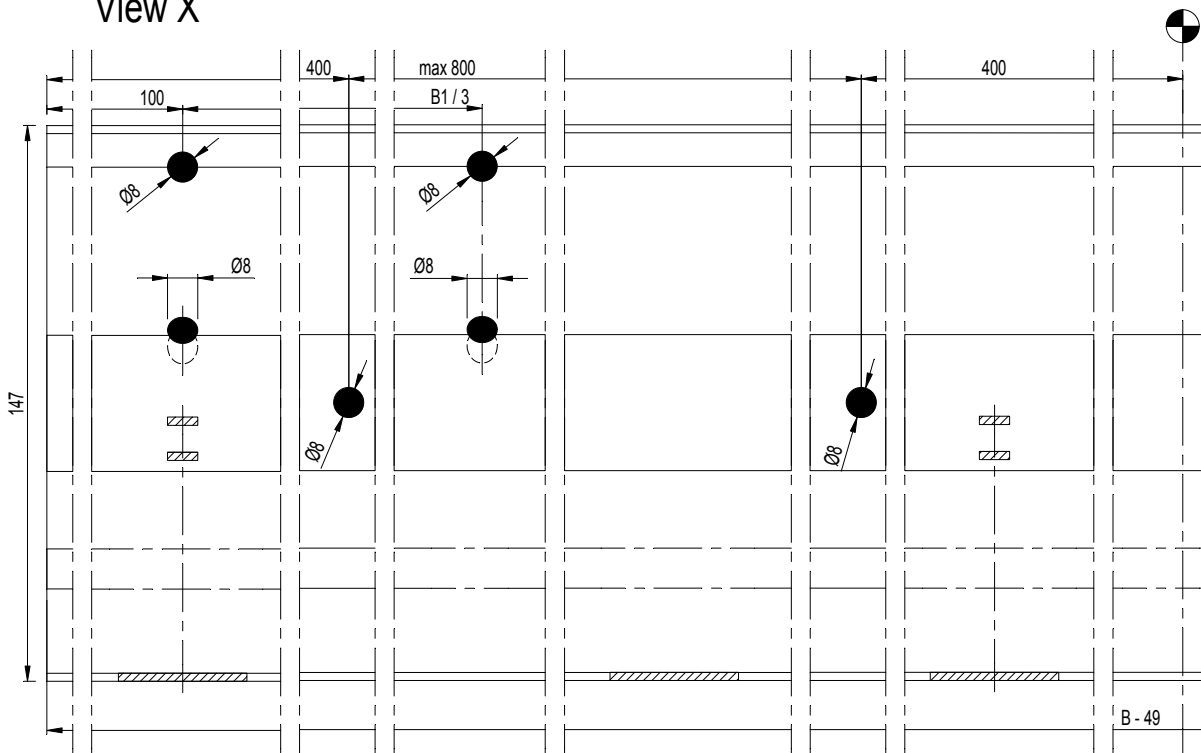

View Y

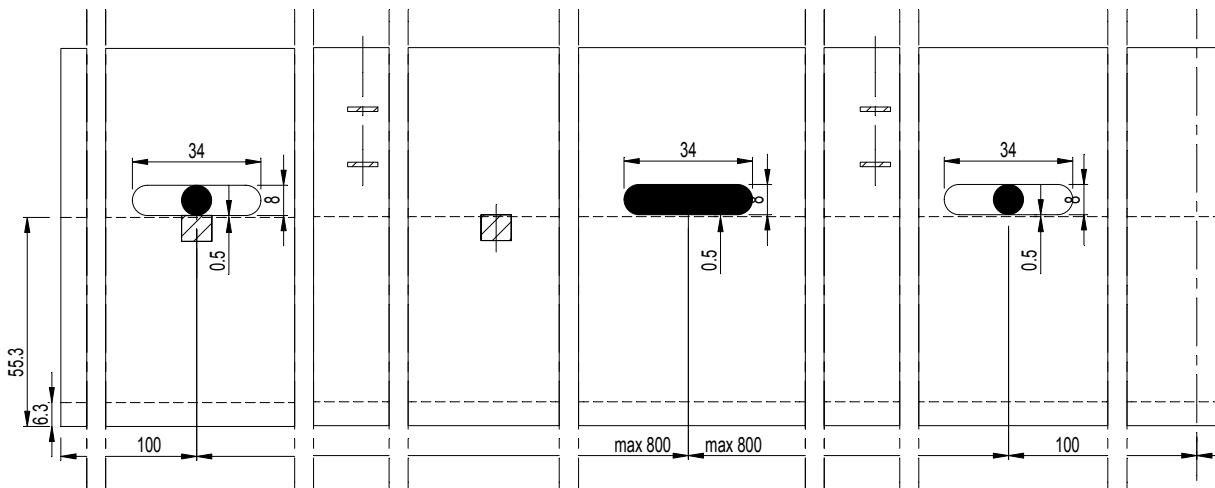

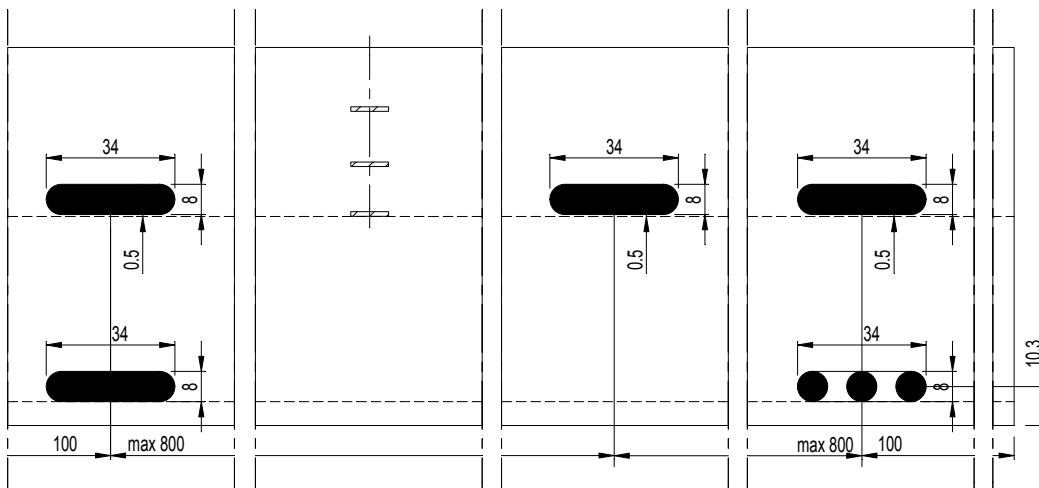
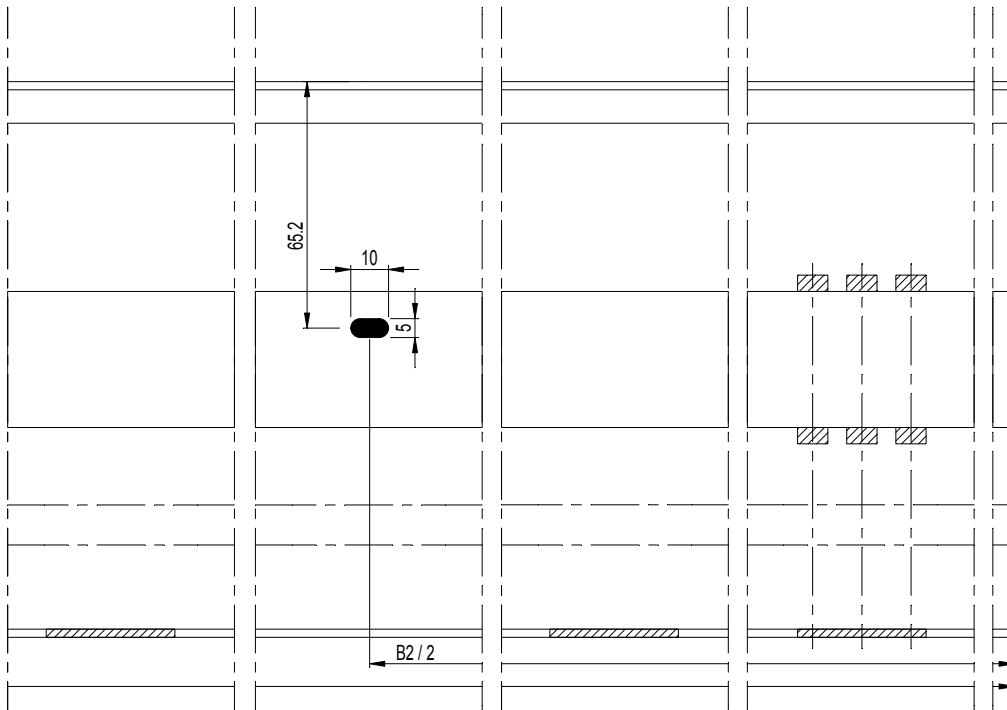
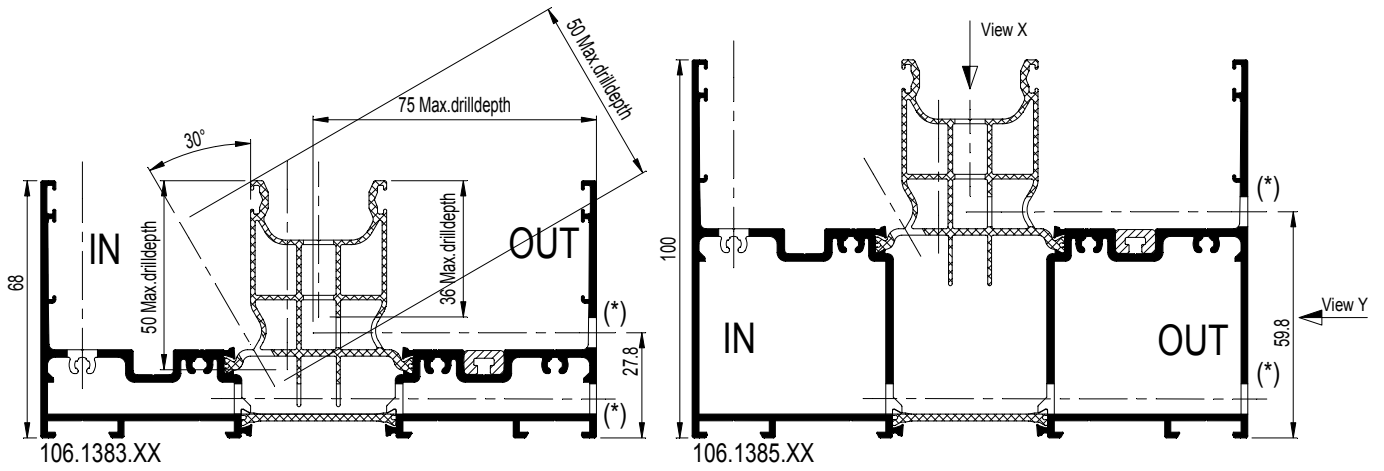

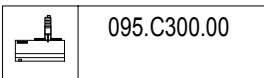
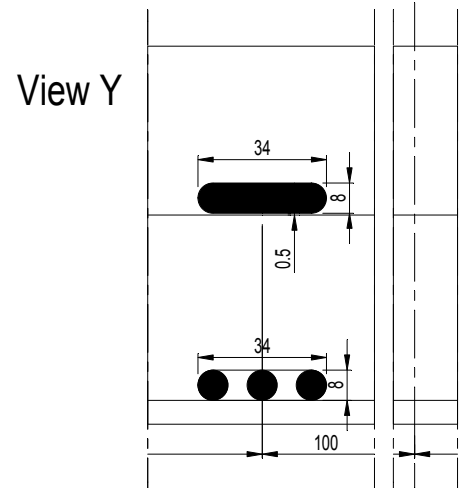
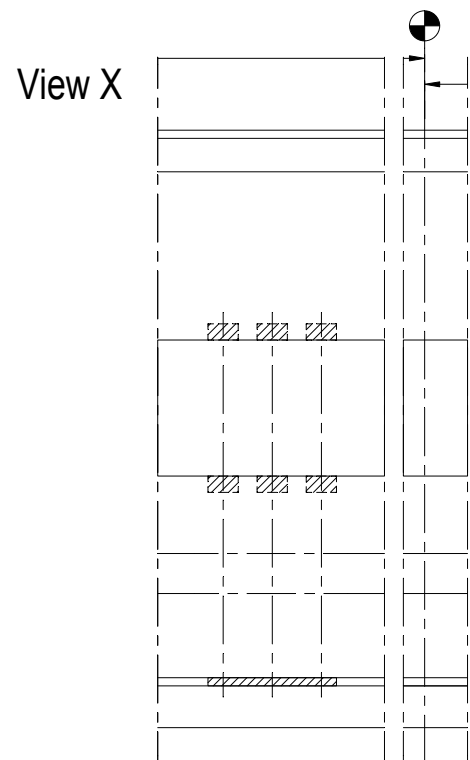
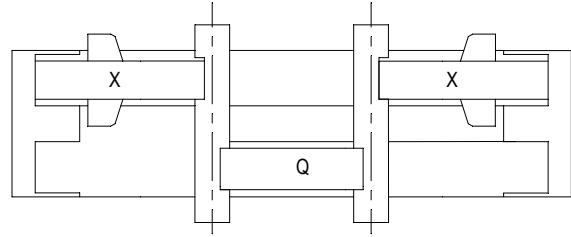
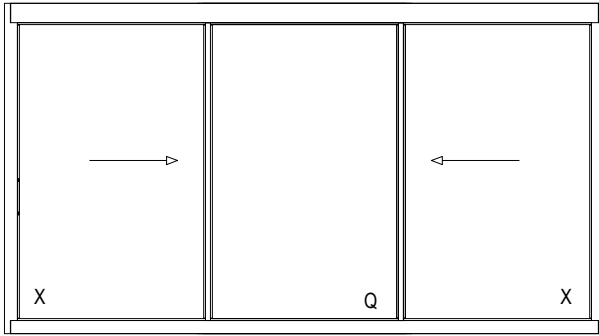

of / ou / or / oder

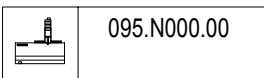

of / ou / or / oder

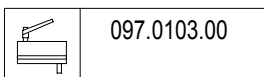



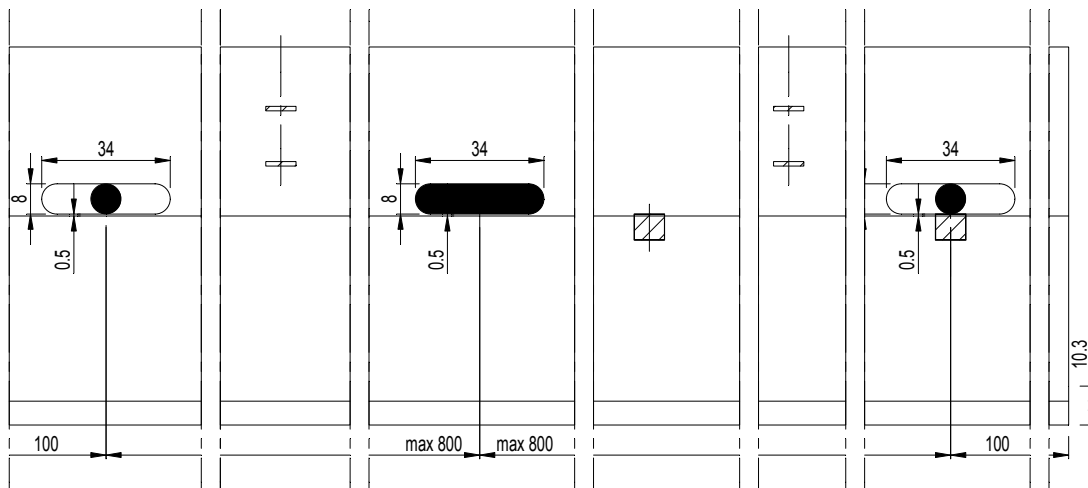
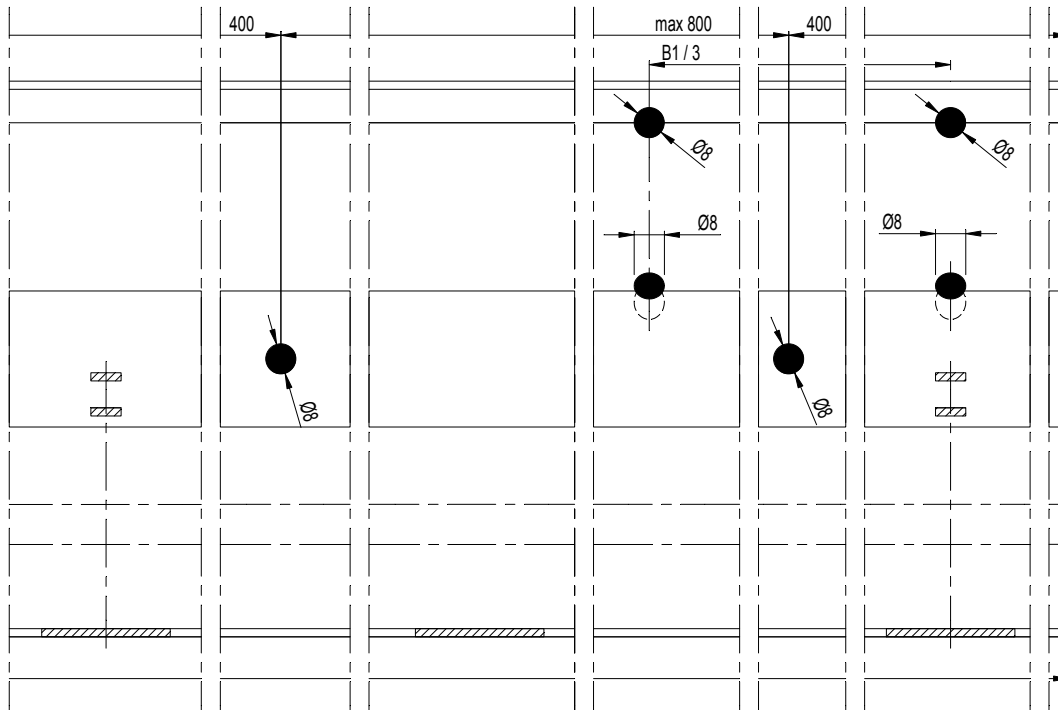
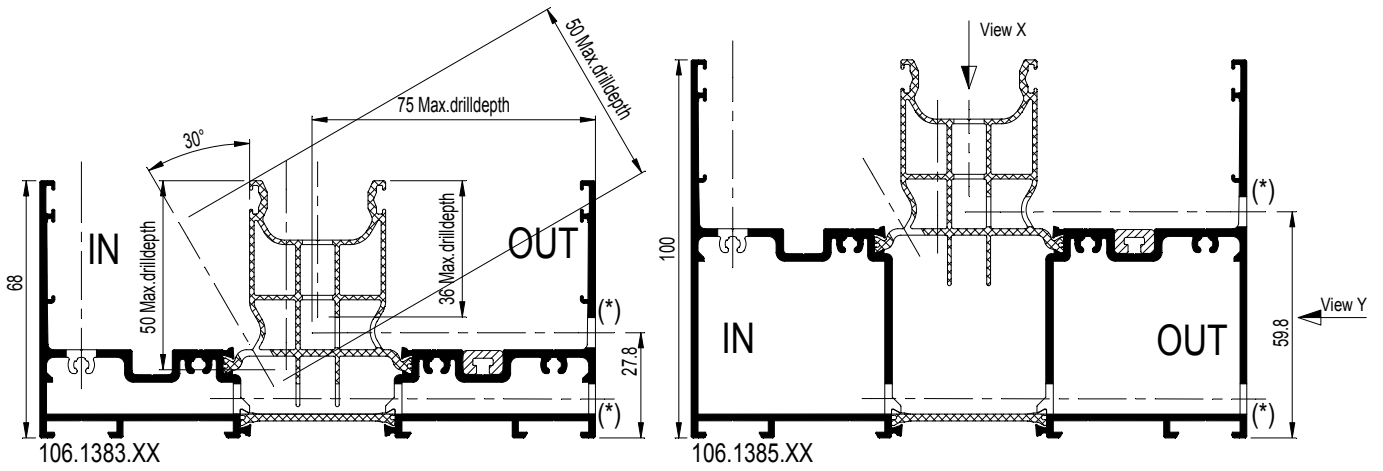

(\*) Ø 8

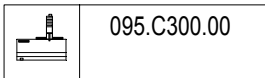
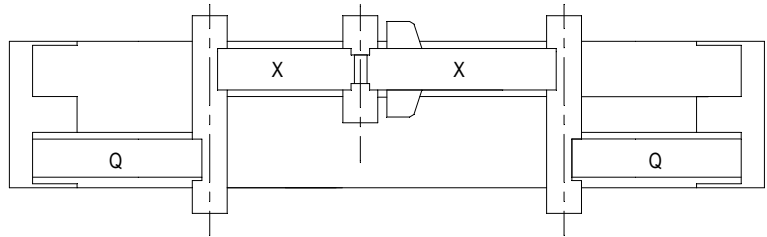
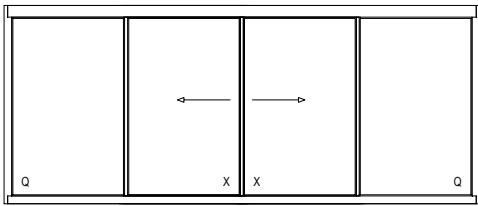

095.C300.00

of / ou / or / oder

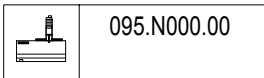

095.N000.00

of / ou / or / oder

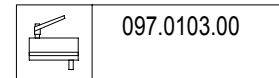

097.0103.00

(\*)

View X

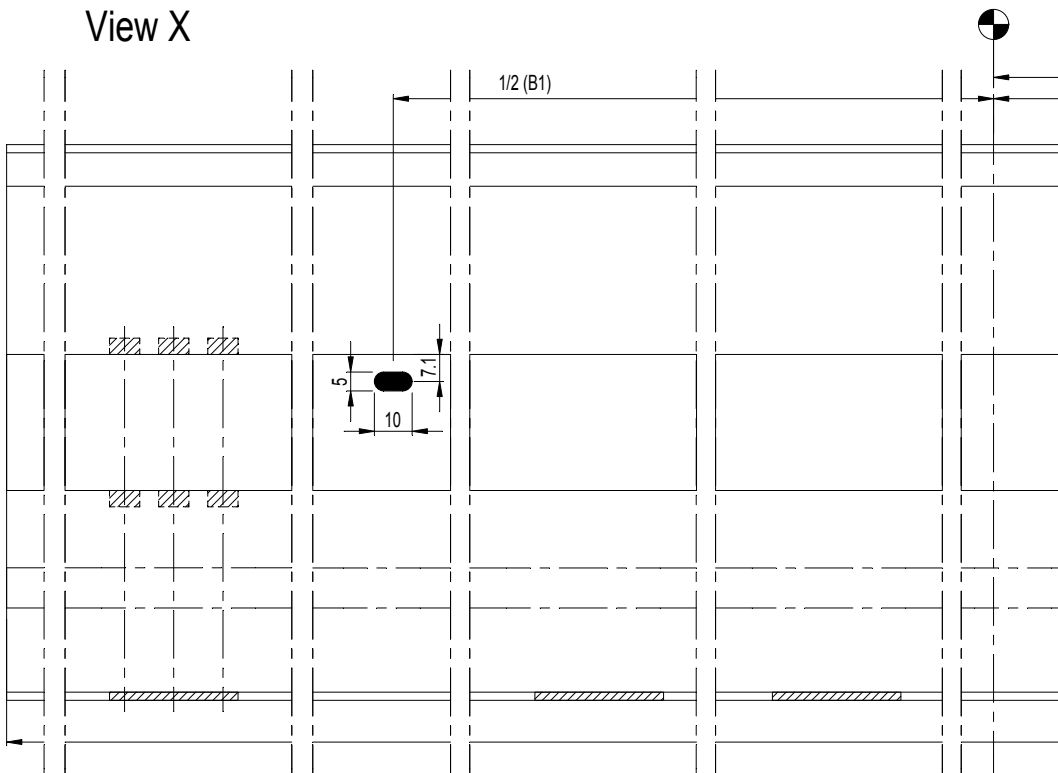

View Y

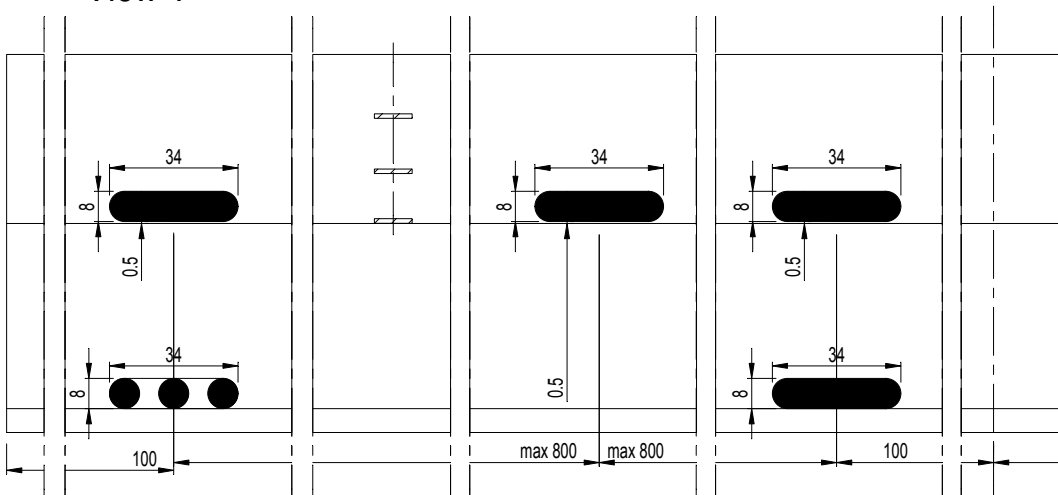

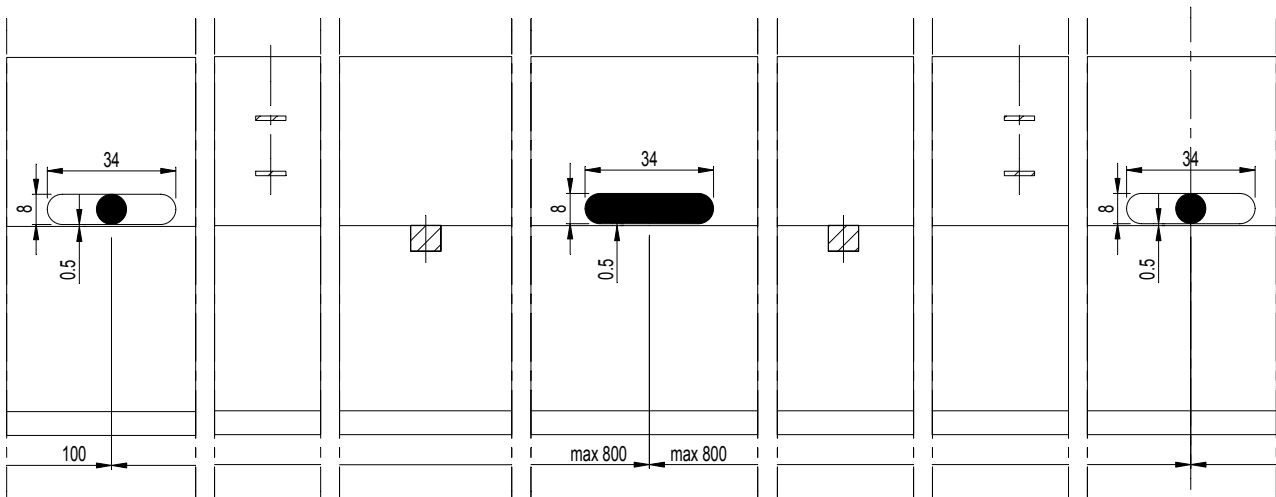
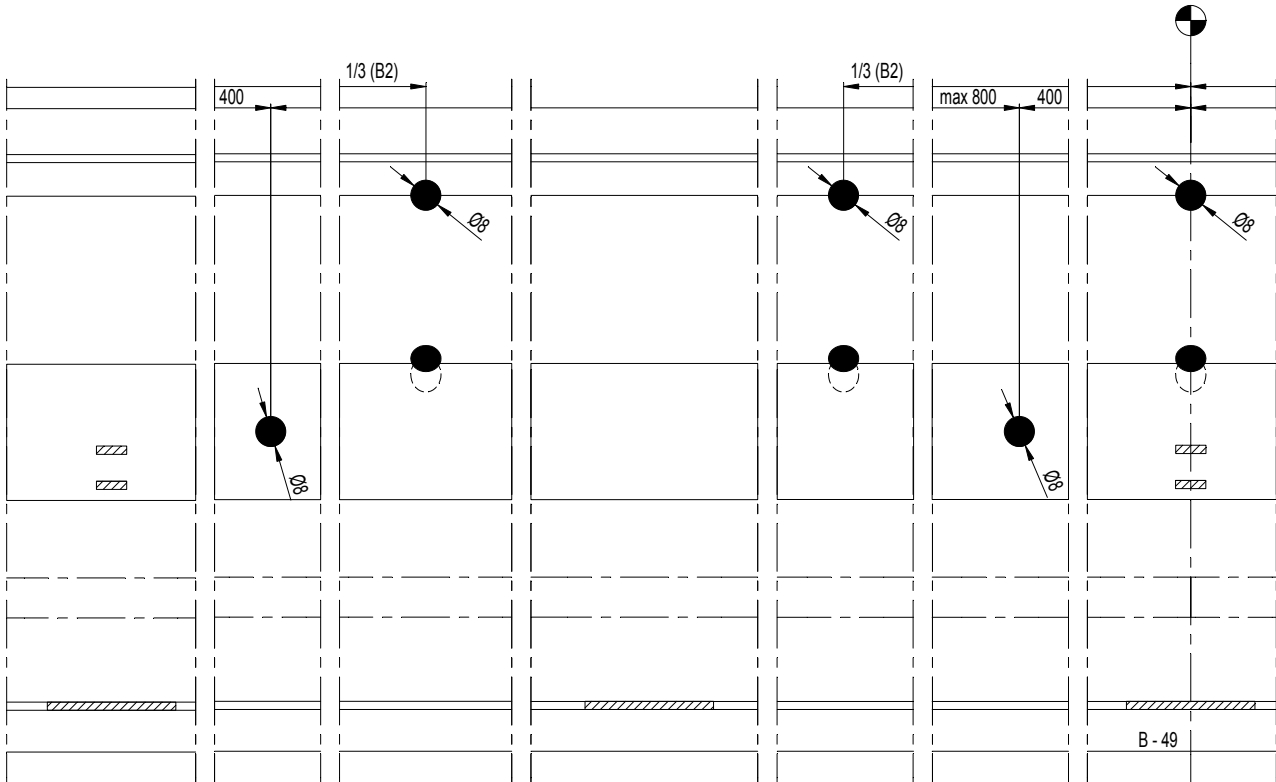
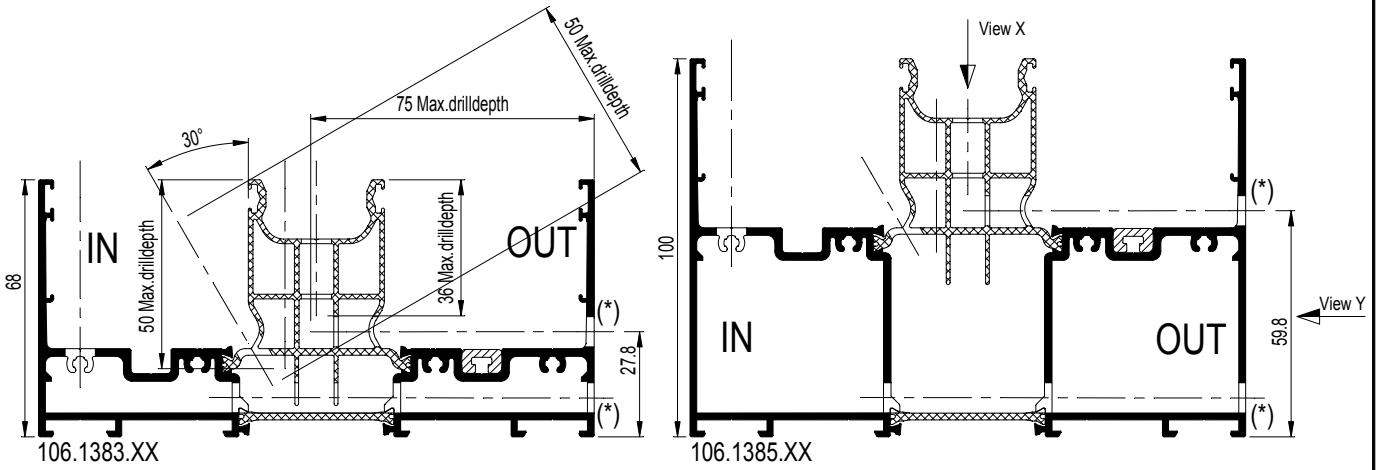

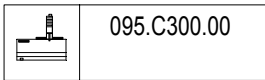
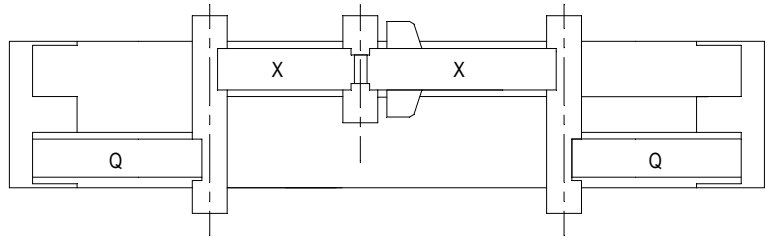
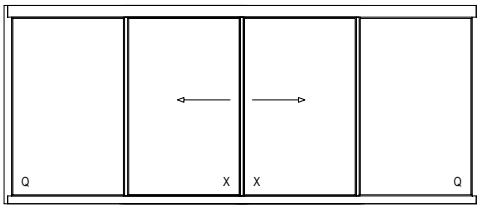

of / ou / or / oder

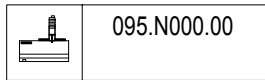

of / ou / or / oder

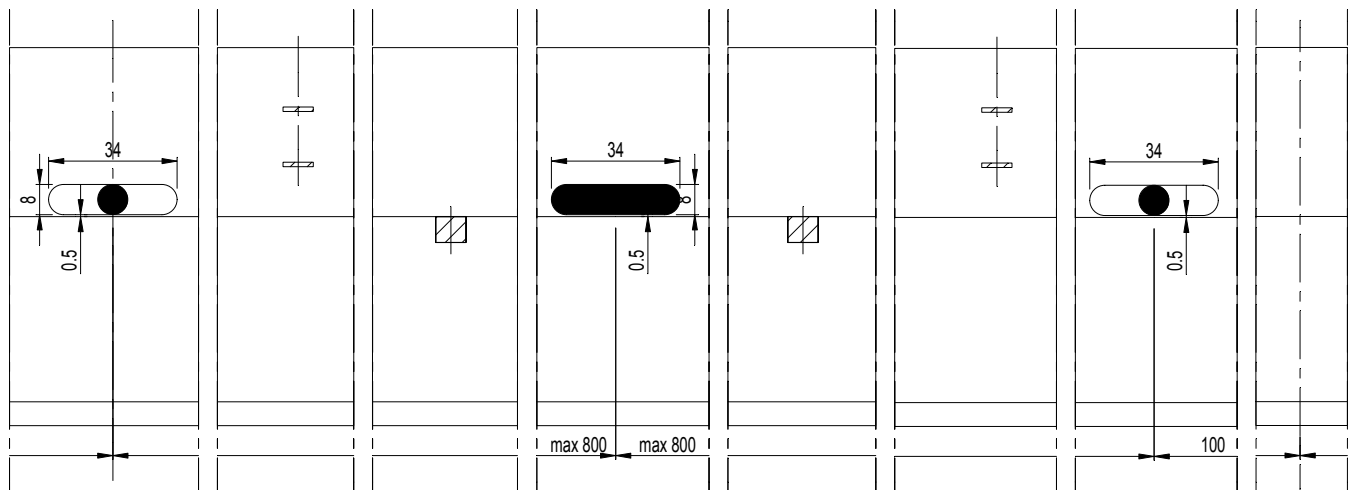
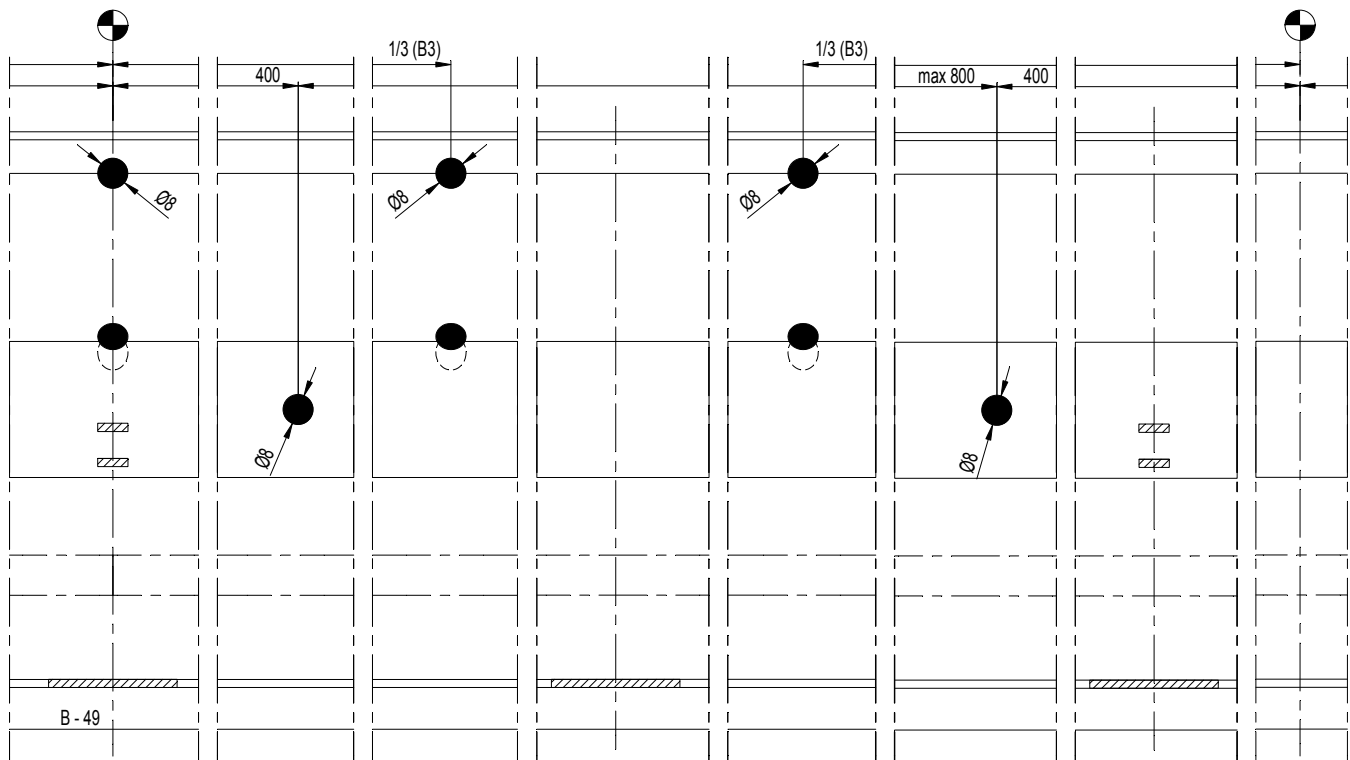
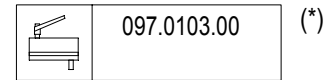

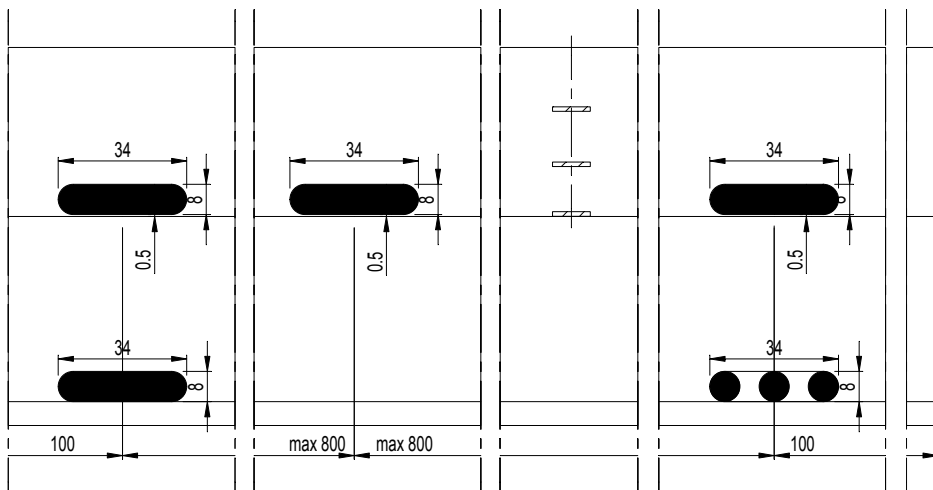
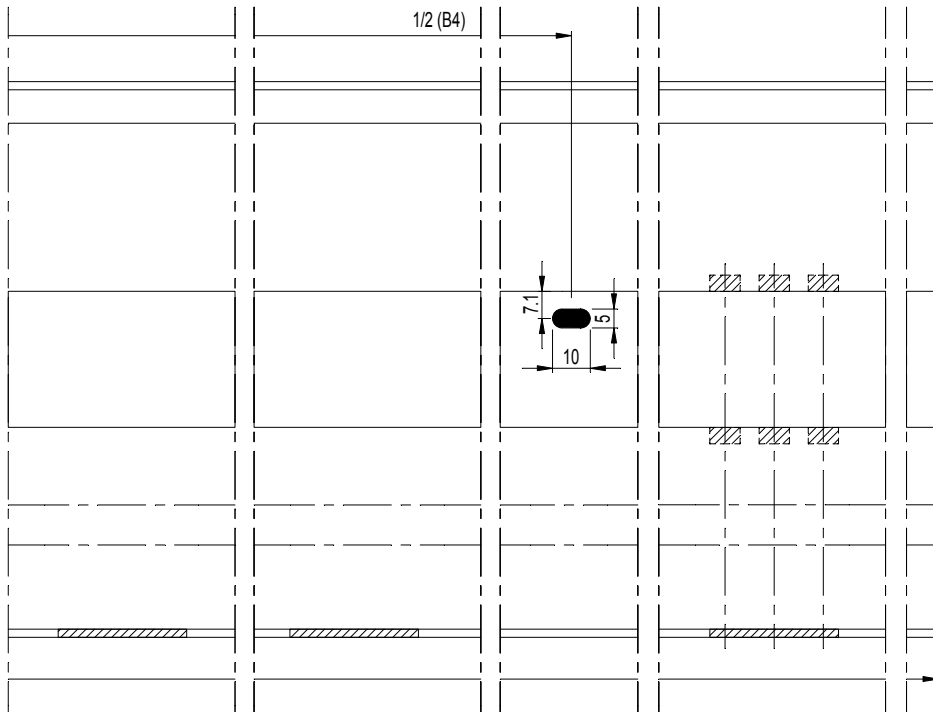
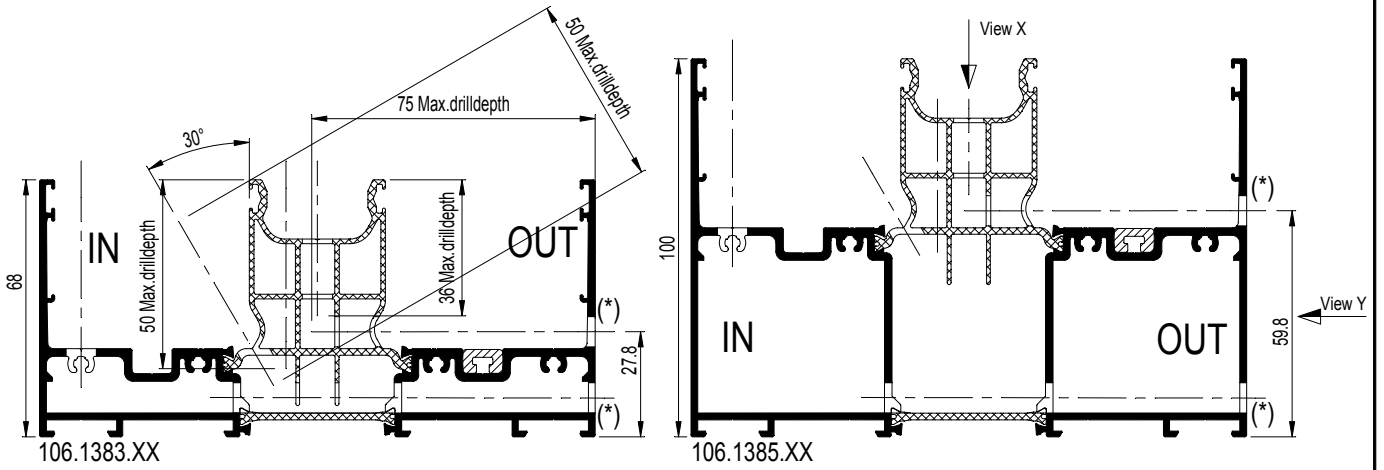

(\*) Ø 8

D0095243

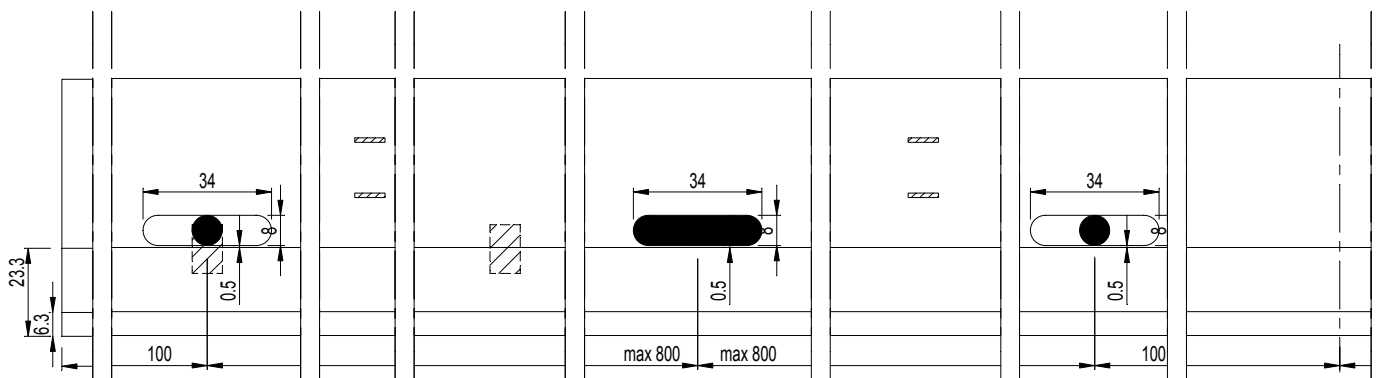
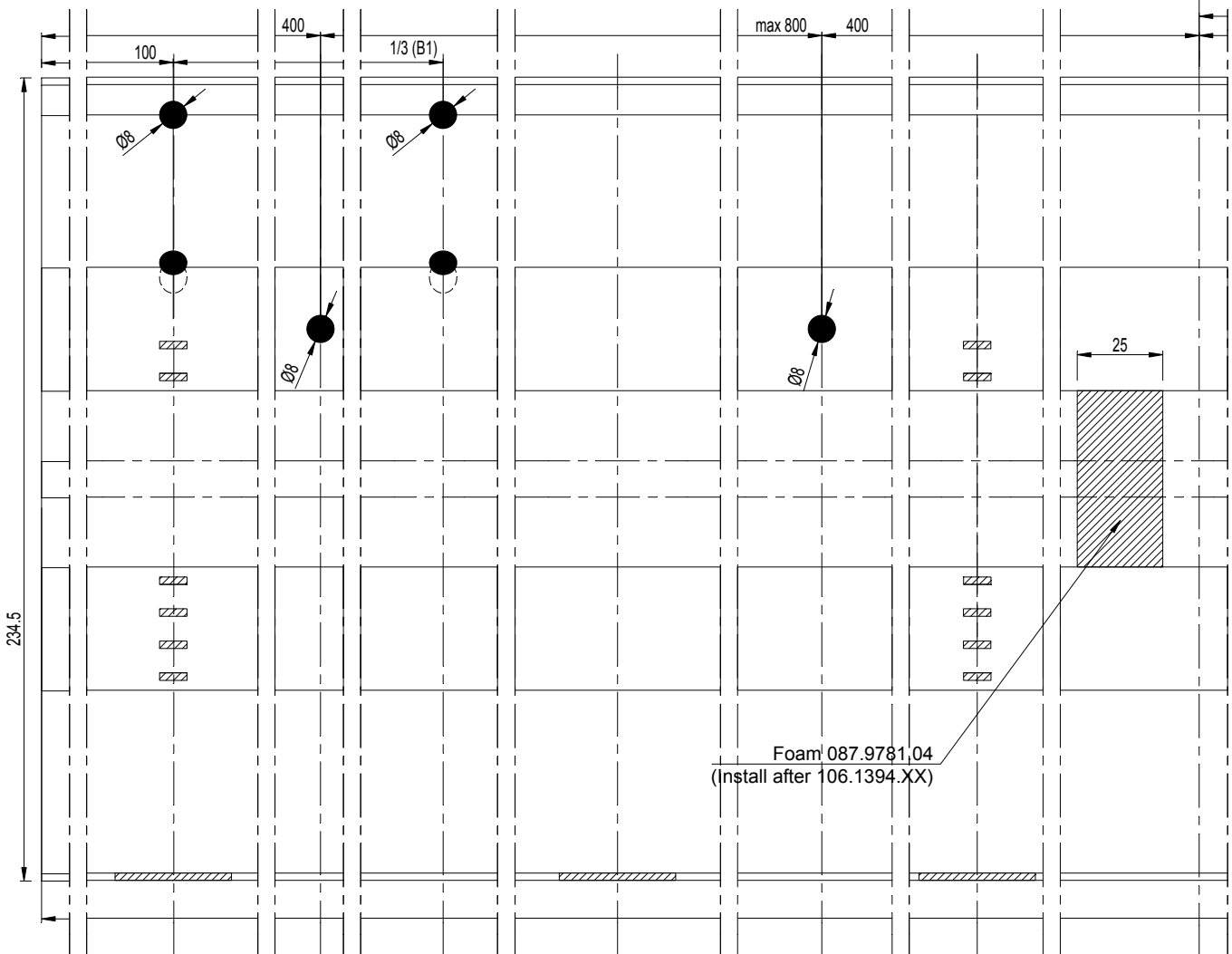
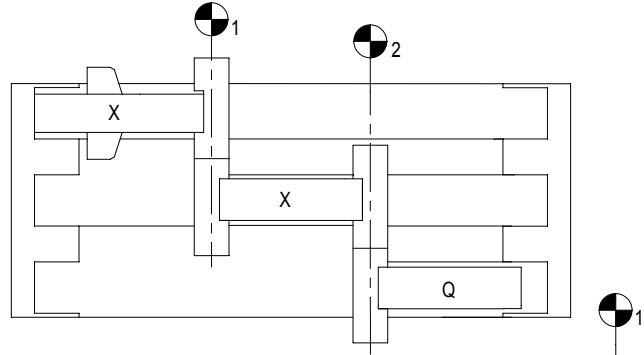
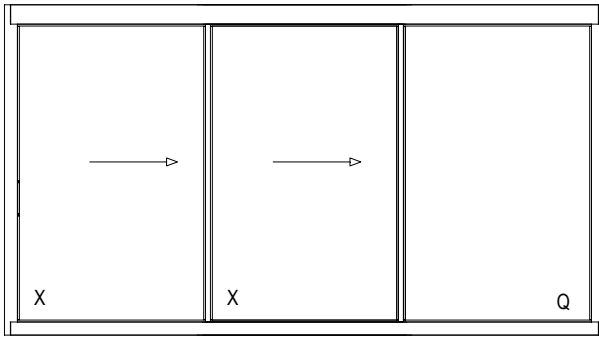

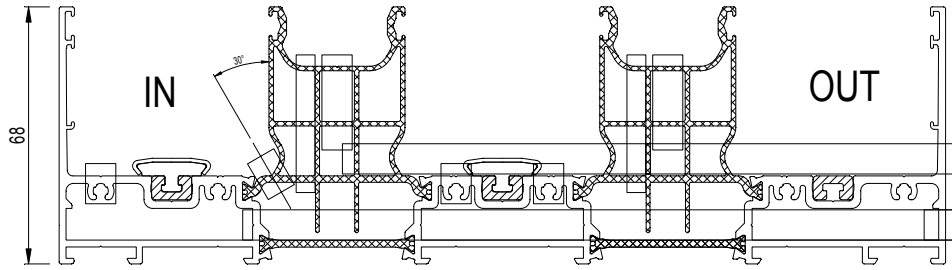

Bodem 106.1399.XX

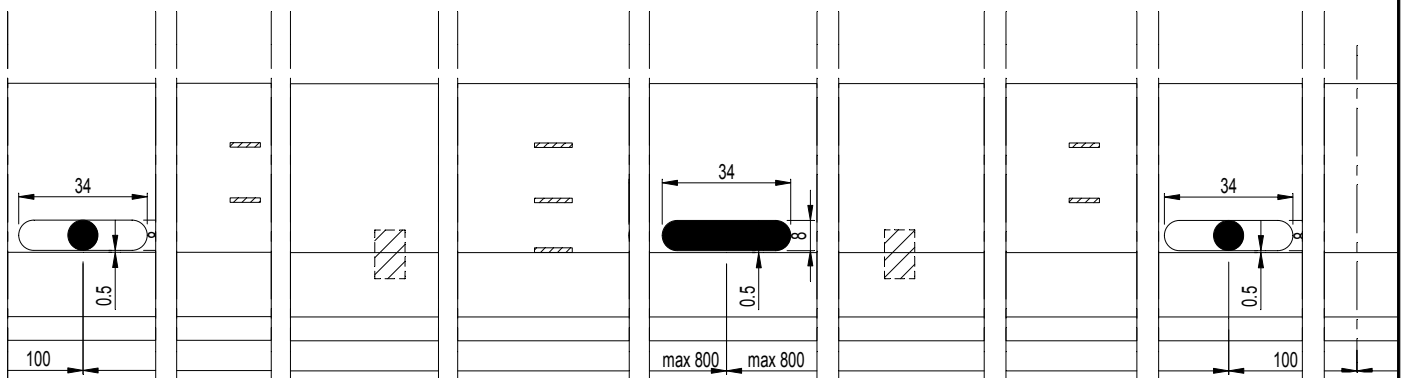
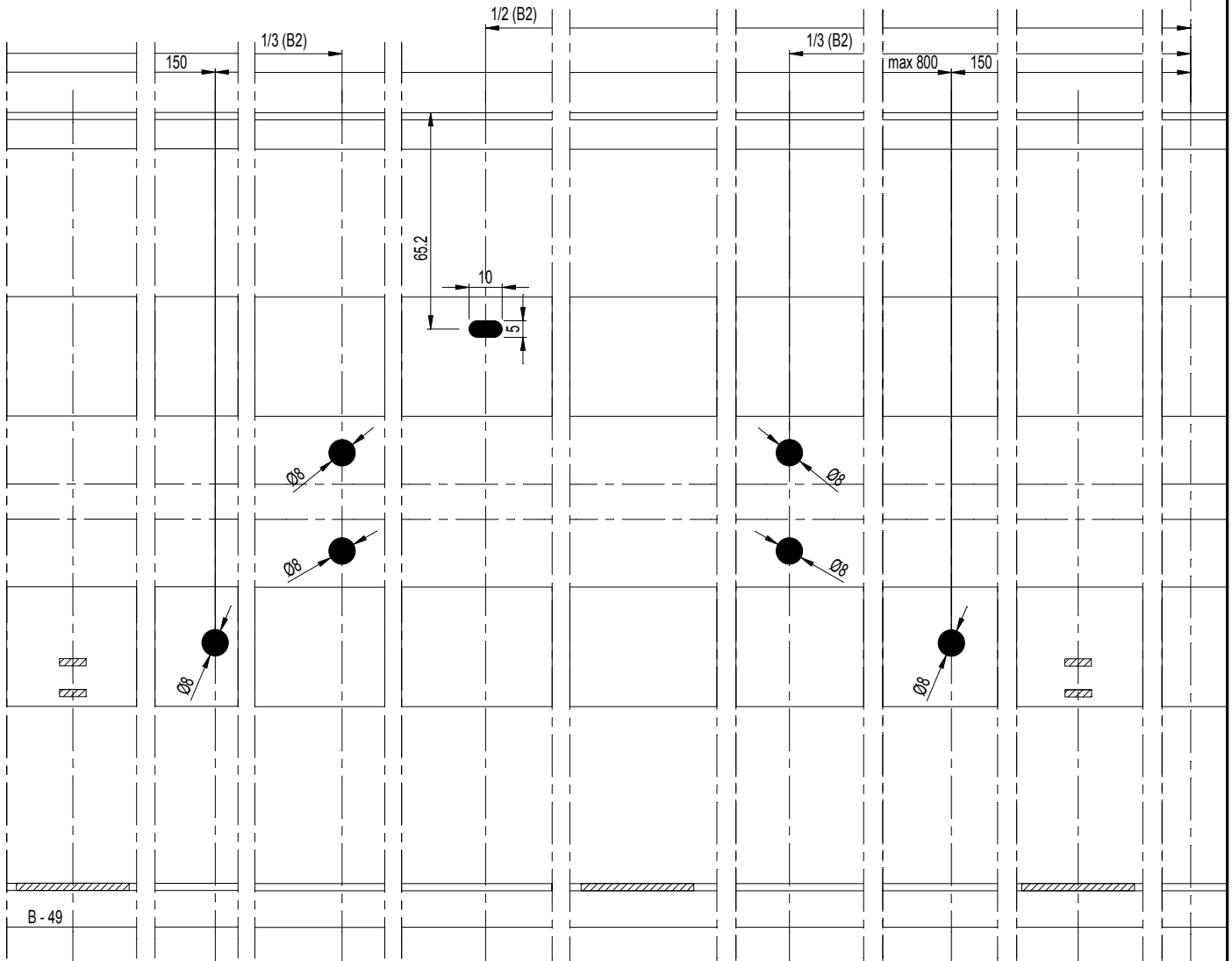

D0096401

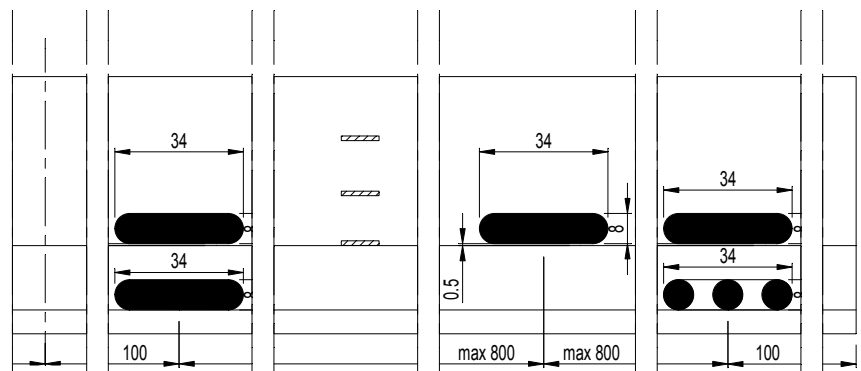
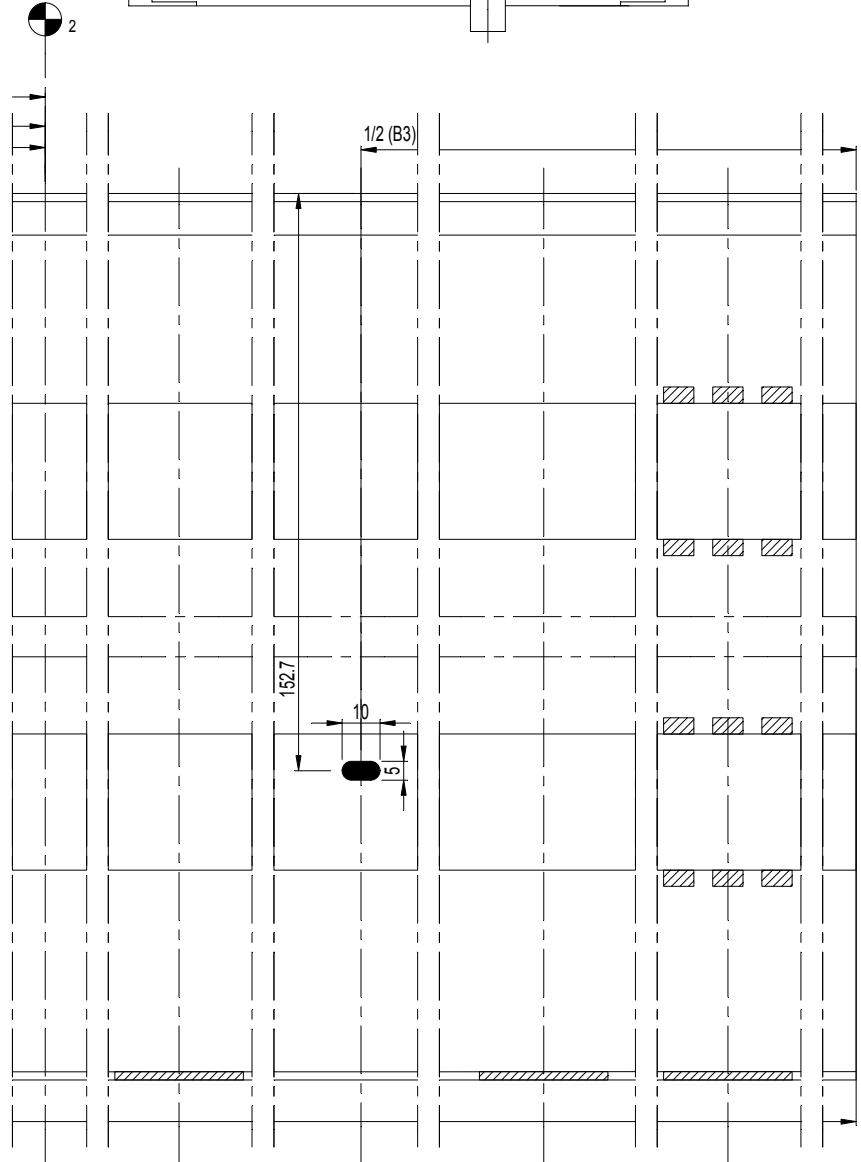
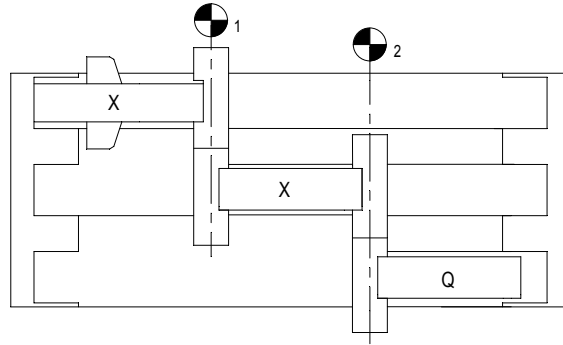
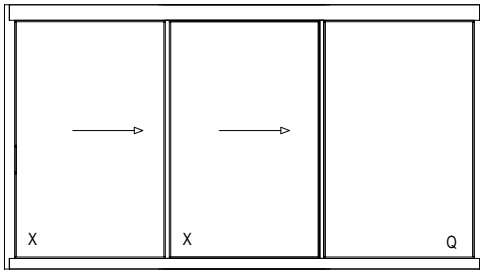

D0096403



## Sealing central gutter

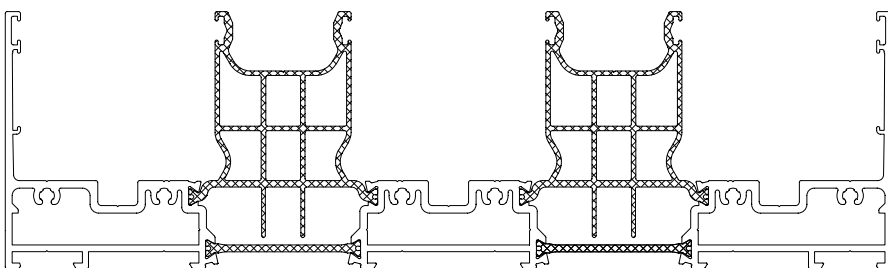
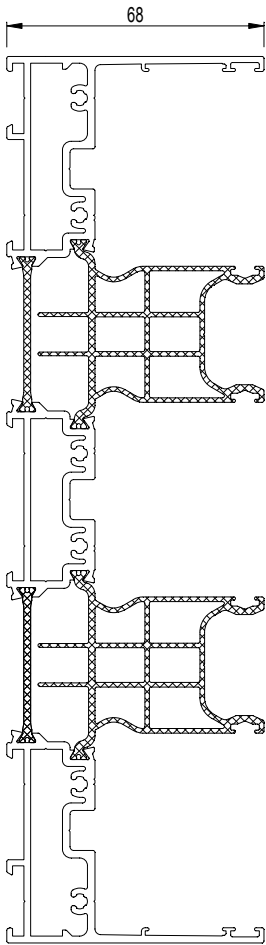
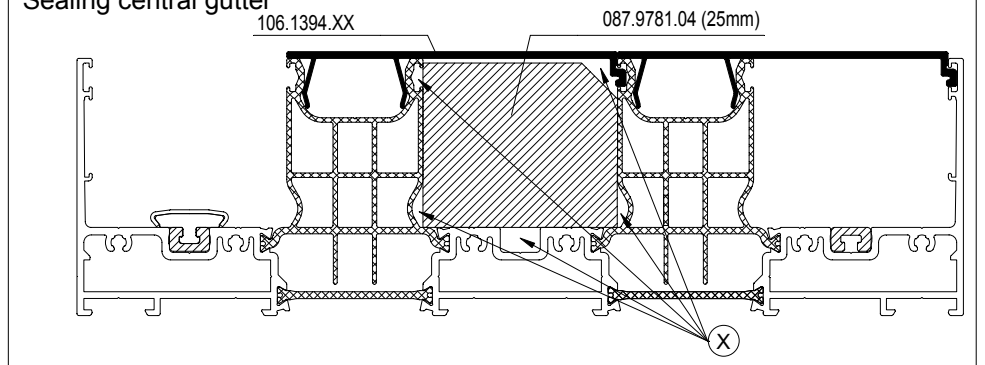

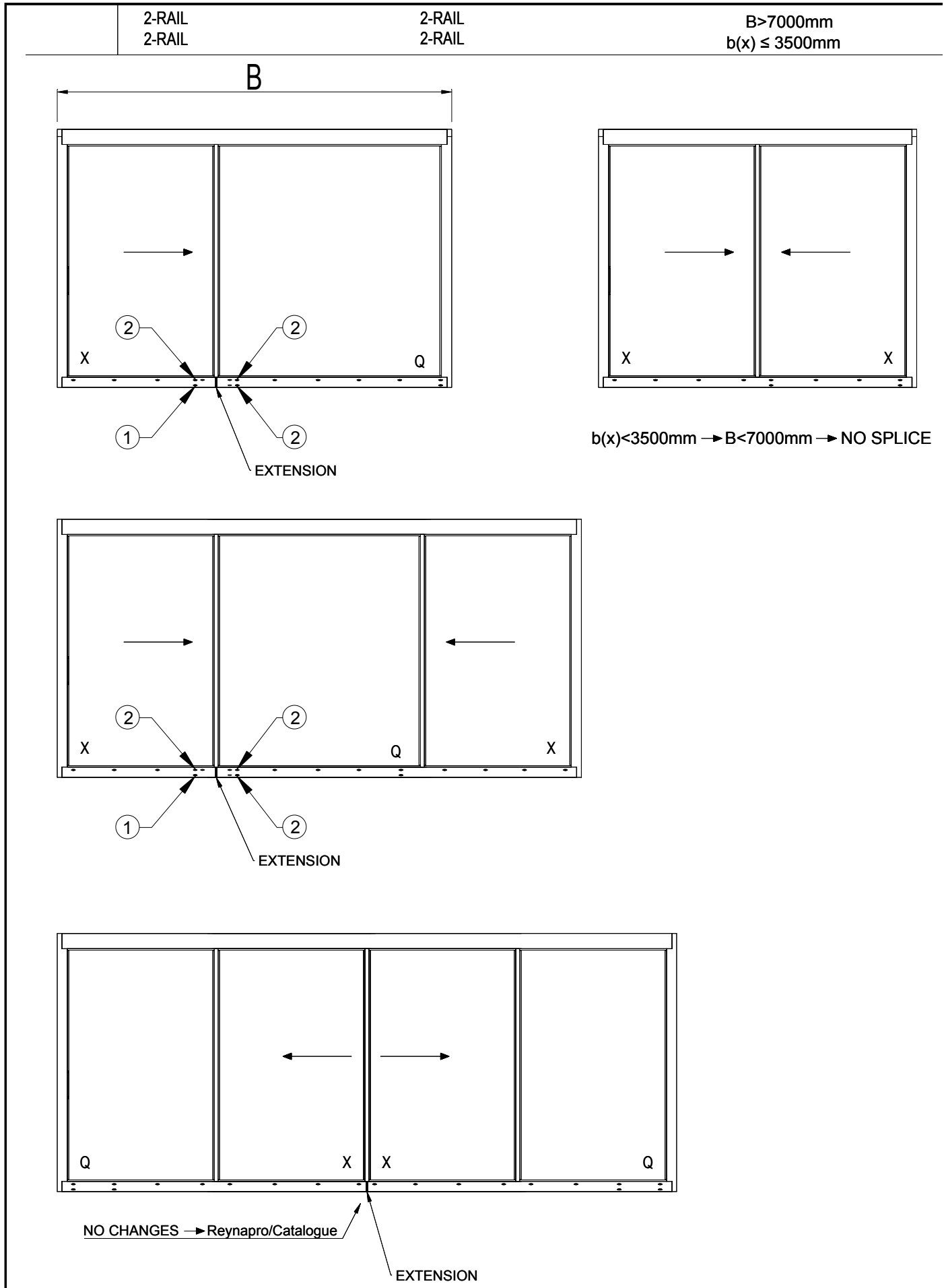

3-RAIL 3-RAIL	3-RAIL 3-RAIL	B>7000mm b(x) ≤ 3500mm
------------------	------------------	---------------------------

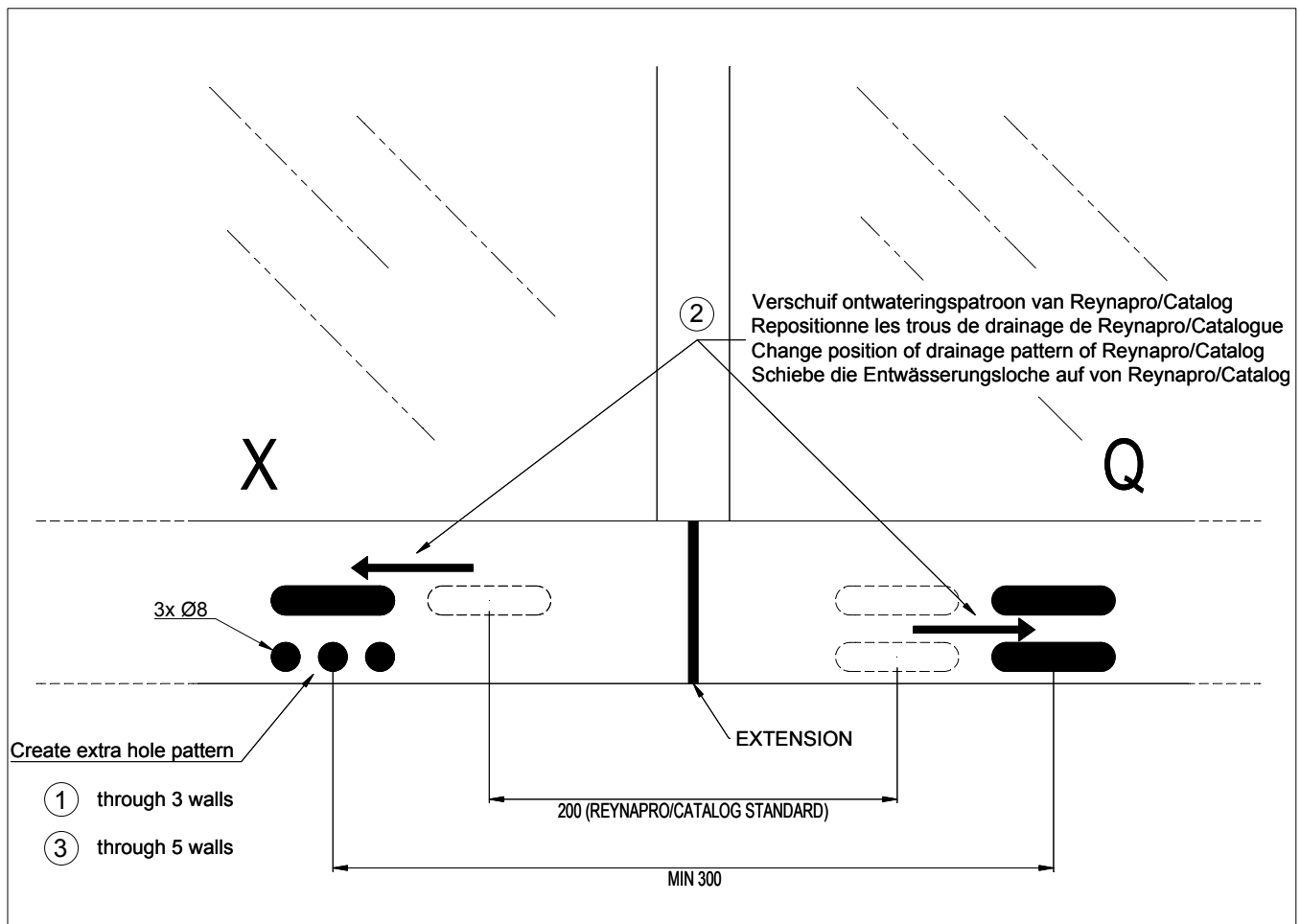
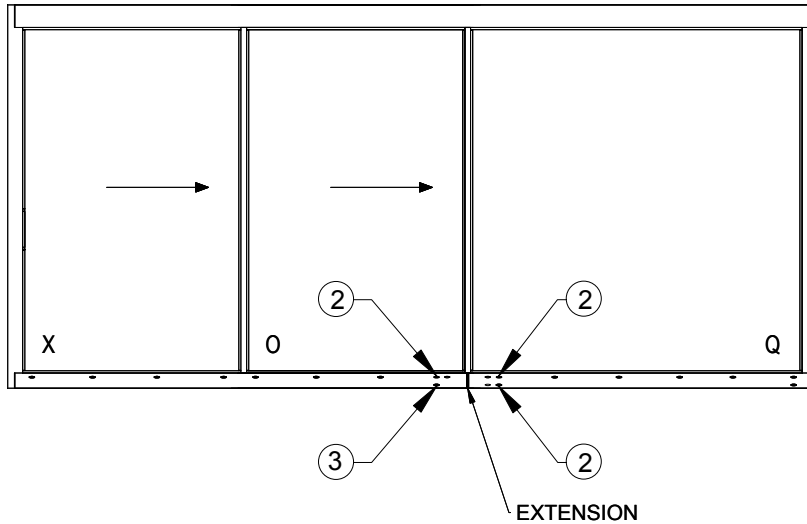

X : PRIMAIRE VLEUGEL  
 Q : VASTE VLEUGEL  
 O : SECUNDAIRE VLEUGEL  
 V : HOEKOPLOSSING

X : OUVRANT PRIMAIRE  
 Q : OUVRANT FIXE  
 O : OUVRANT SECONDAIRE  
 V : SOLUTION ANGULAIRE

X : PRIMARY SLIDING VENT  
 Q : FIXED VENT  
 O : SECONDARY SLIDING VENT  
 V : CORNER SOLUTION

X : GANGFLUEGEL  
 Q : FENSTER FLUEGEL  
 O : STANDFLUEGEL  
 V : ECKLÖSUNG

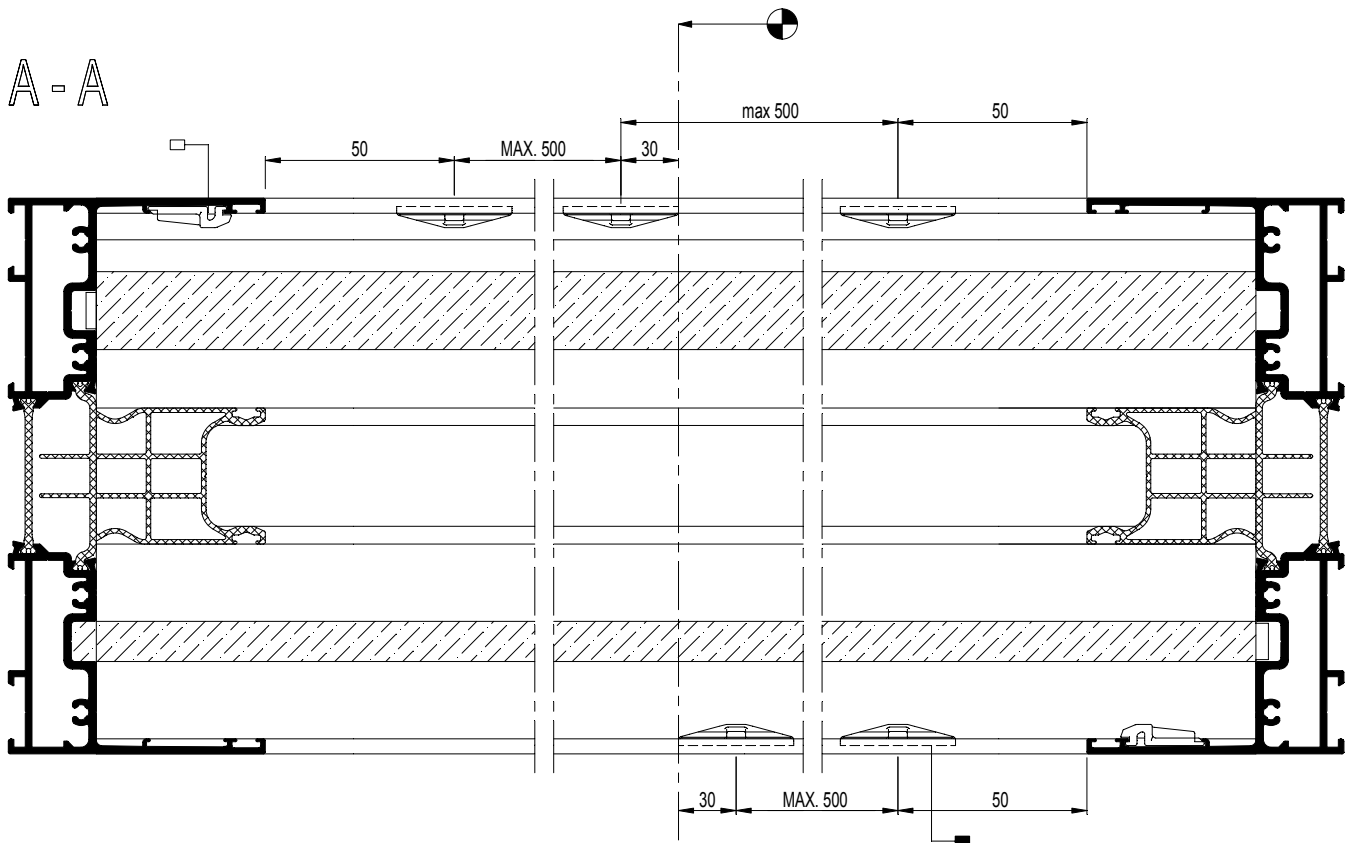
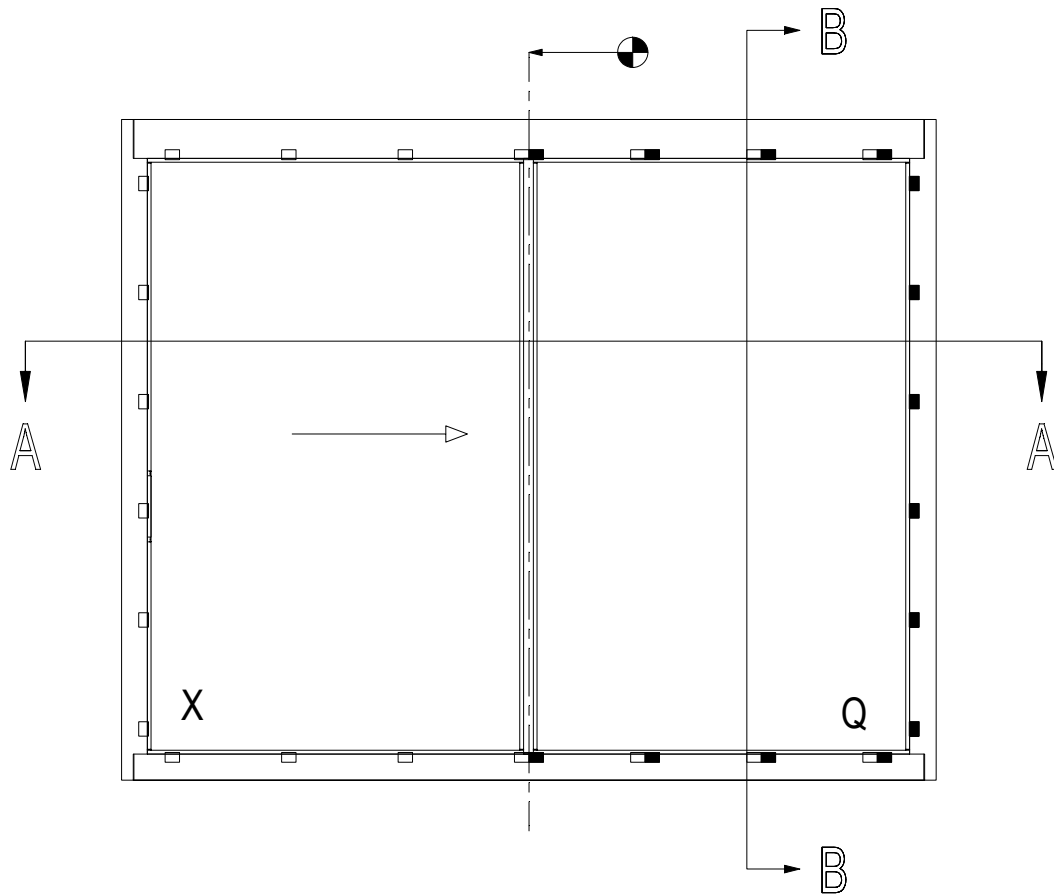

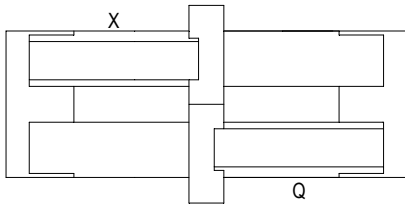

B - B

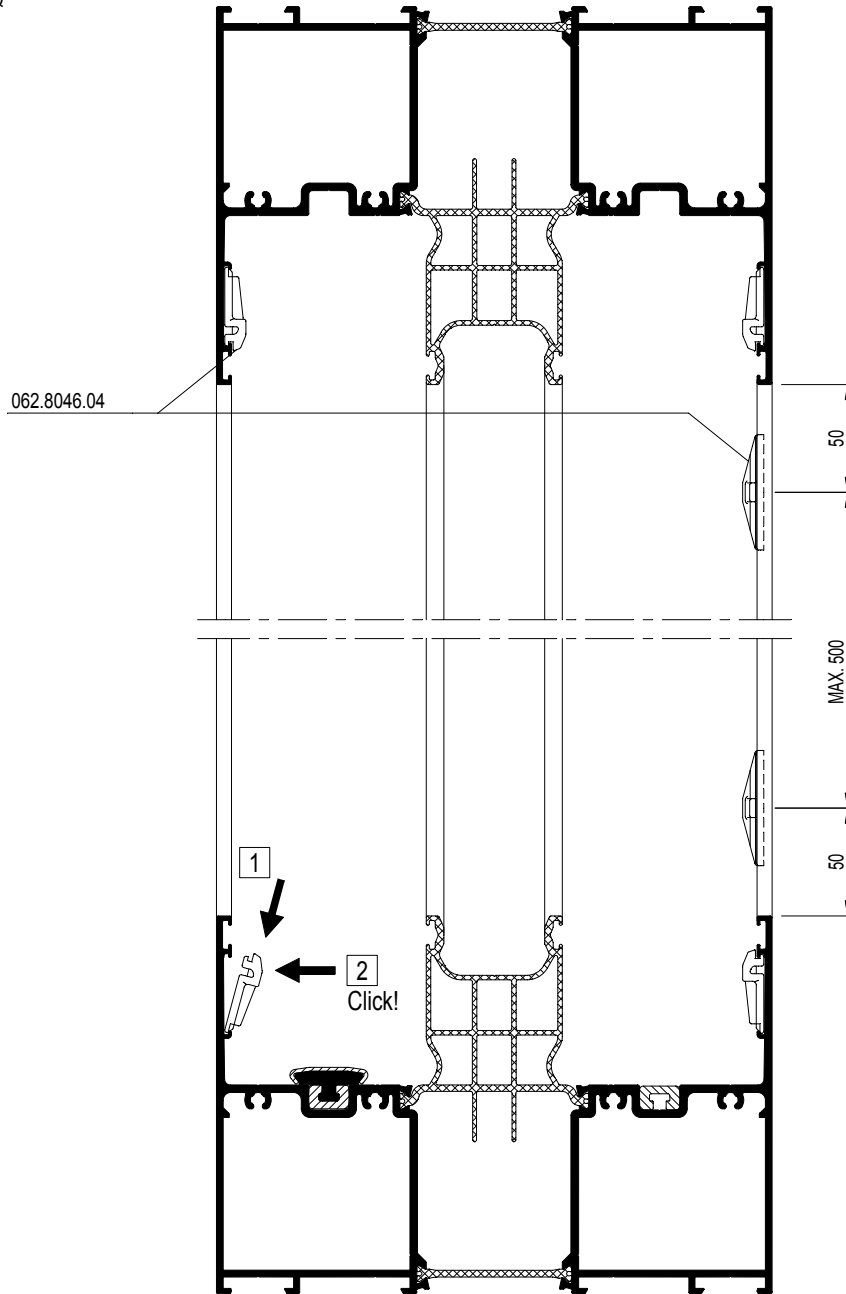

MONTAGEVOLGORDE L'ORDRE DE MONTAGE THE ORDER OF ASSEMBLY MONTAGEREIHENFOLGE	1	2	3	.
--	---	---	---	---

A-A

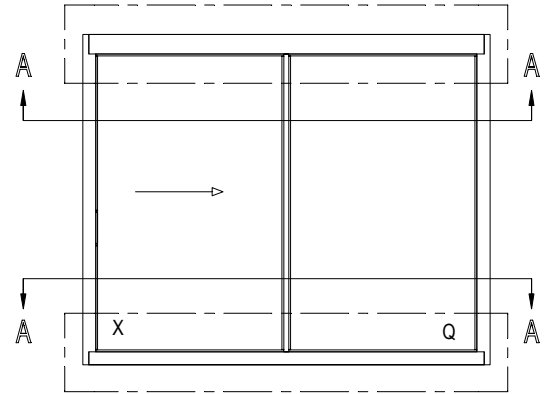
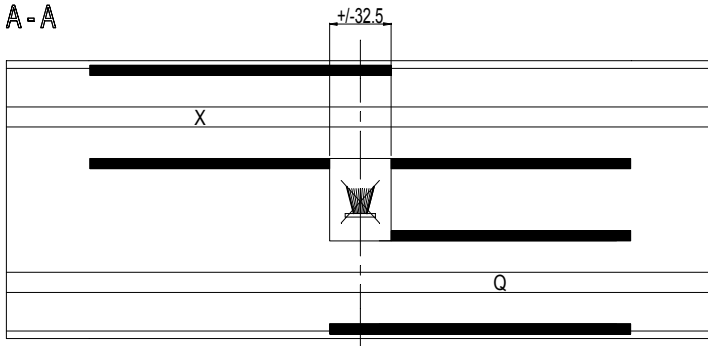

B-B

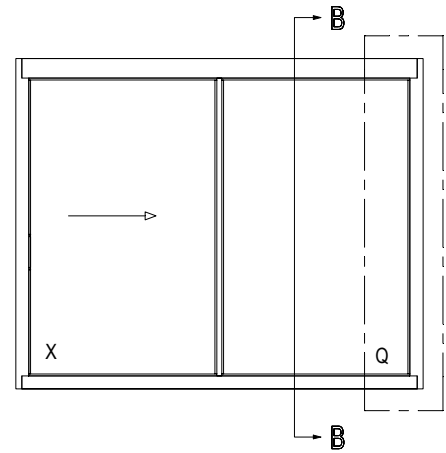
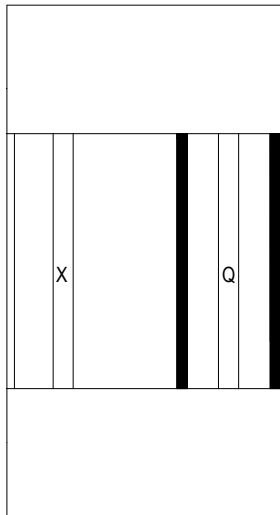

C-C

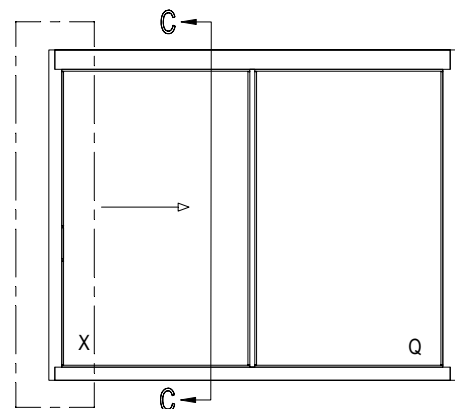
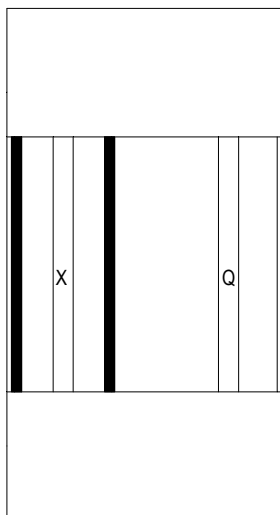

MONTAGE MOGELIJK NU OF LATER  
MONTAGE POSSIBLE MAINTENANT OU APRES  
ASSEMBLY POSSIBLE NOW OR LATER  
MONTAGE MOGLICH JETZ ODER NACH



ZIE 25D.F.... "DICHTINGSSTUK VOOR WISSELPROFIEL"  
VOIRE 25D.F.... "JOINT D'ASSEMBLAGE POUR CHICANE"  
SEE 25D.F.... "GASKET FOR MEETING SECTION PERFIL CENTRAL"  
SIEHE 25D.F.... "DICHTUNGSTUECK FUER WECHSELPROFIL"

062.8081.04

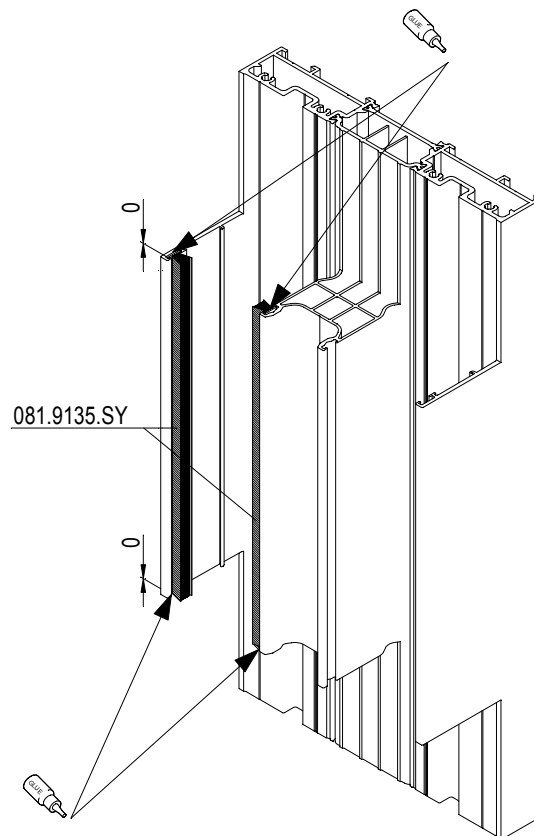
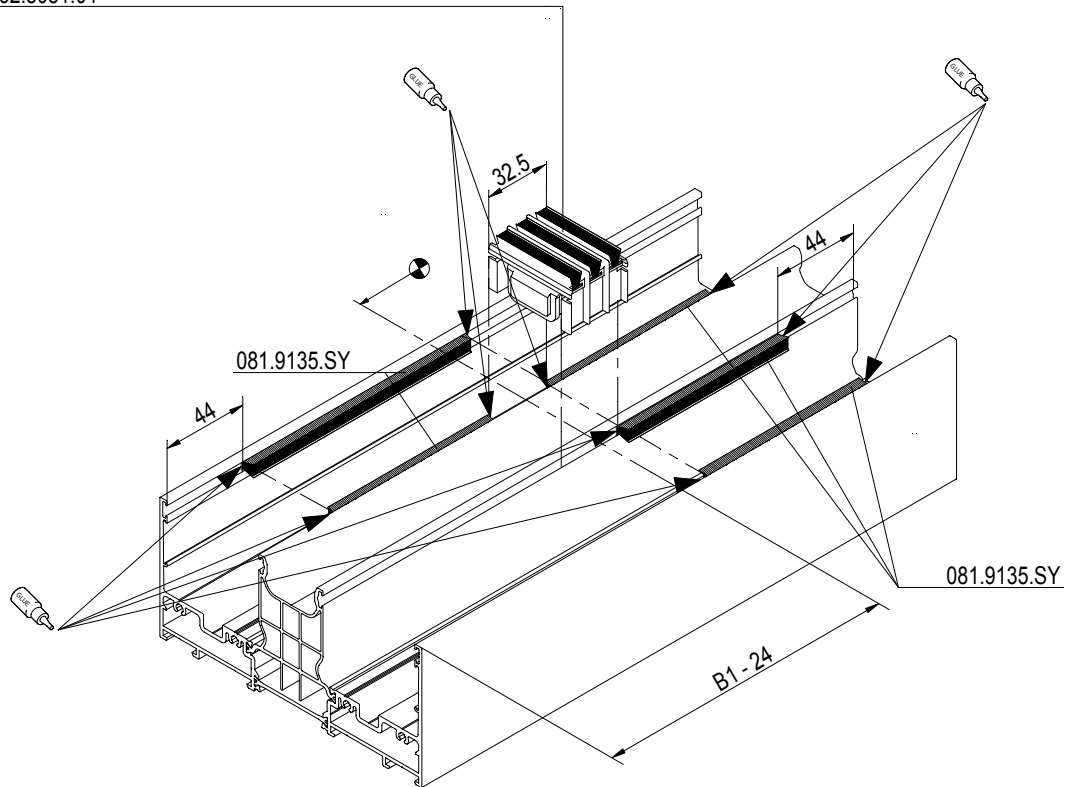

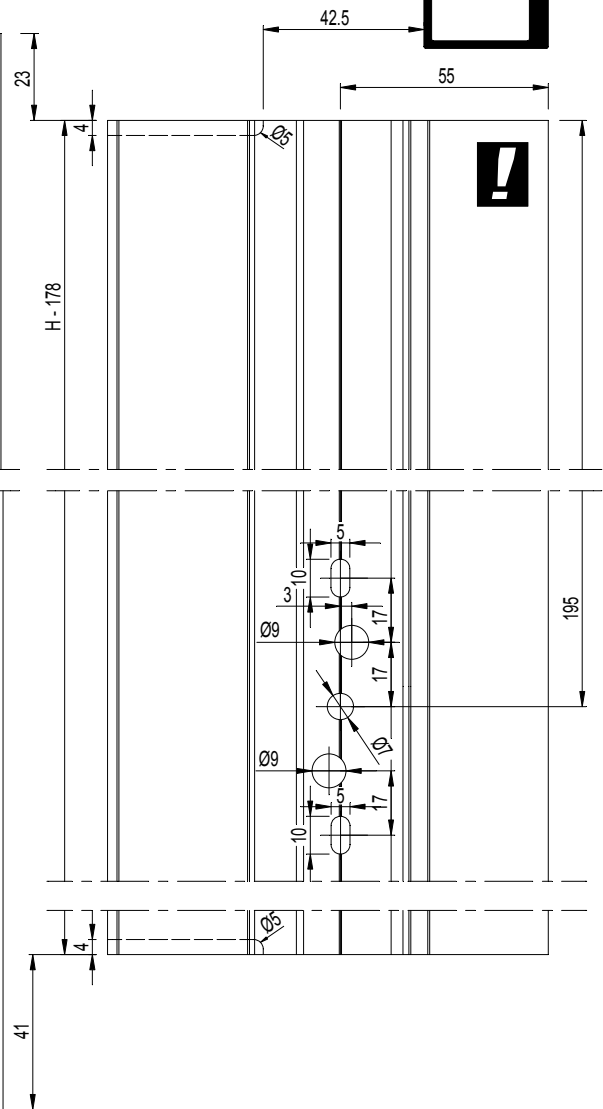
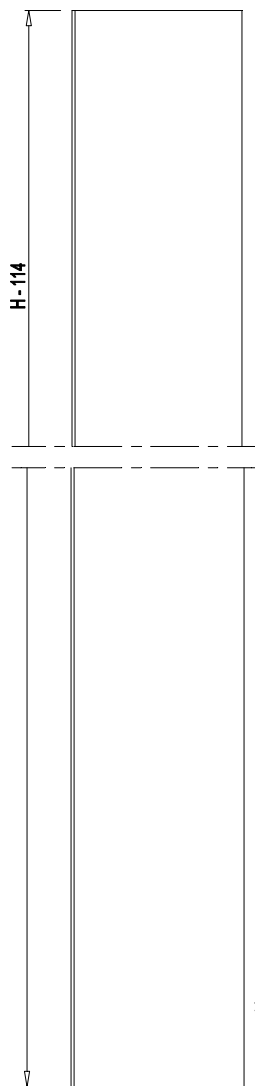
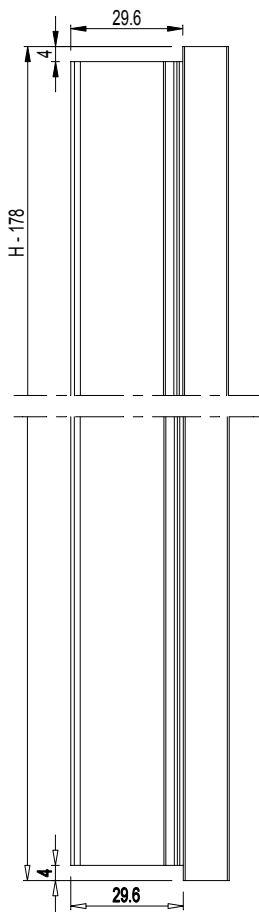
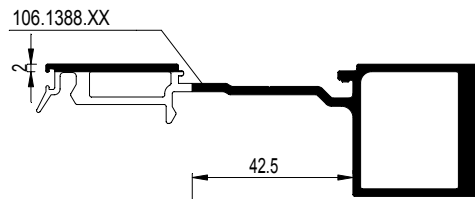
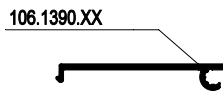
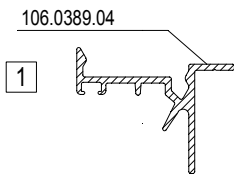
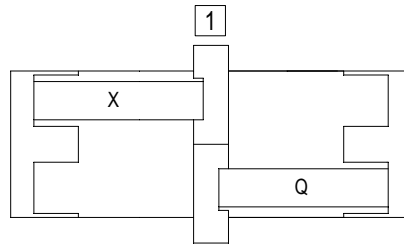
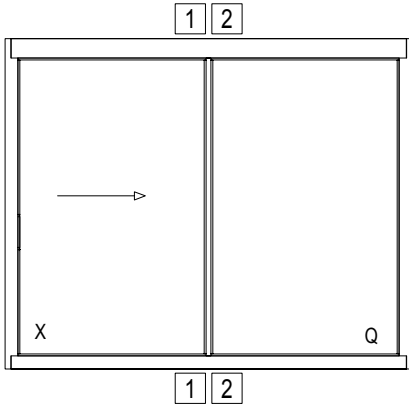

**!** MARKEREN SCHUIVENDE BOVENKANT  
 MARQUAGE DESSUS PROFILE COULISSANT  
 MARK TOP SLIDING PROFILE  
 MARKIEREN FESTEN OBENSEITE



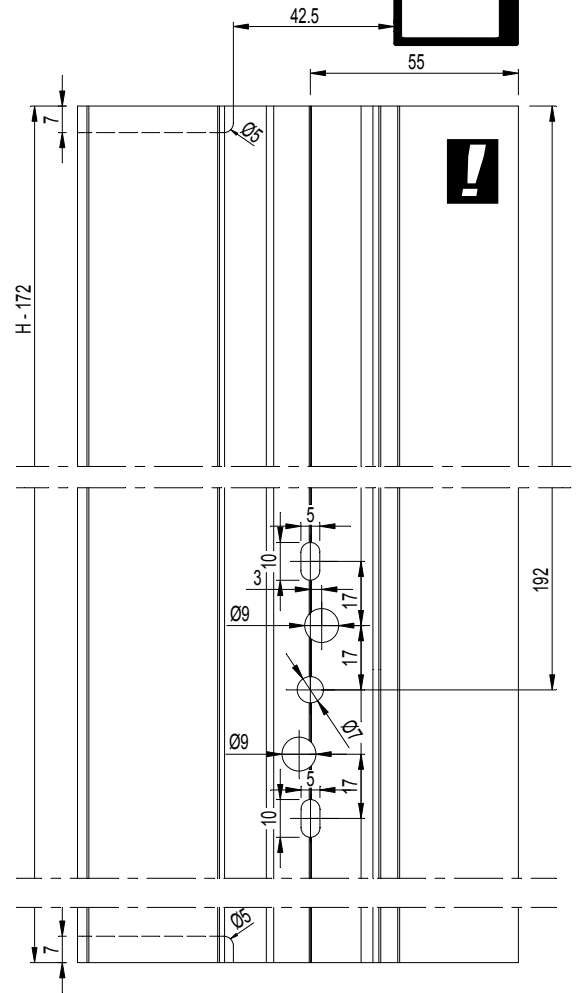
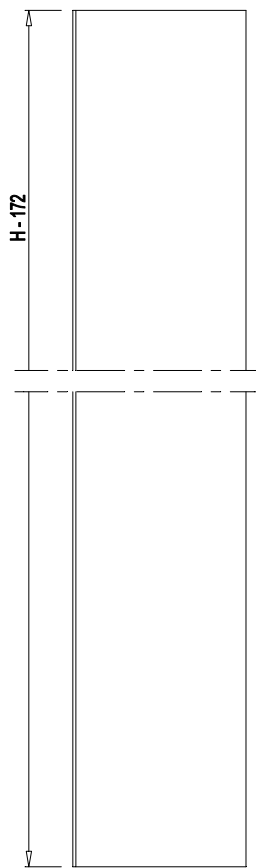
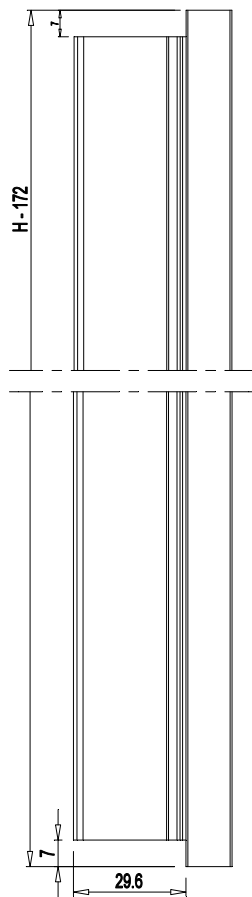
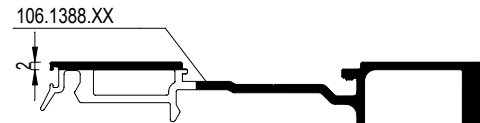
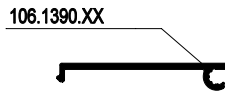
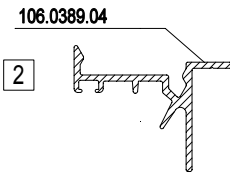
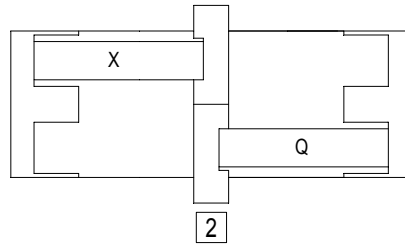

**!** MARKEREN VASTE BOVENKANT  
MARQUAGE DESSUS PROFFILE FIXE  
MARK FIXED FRAME  
MARKIEREN FESTEN FLUEGEL

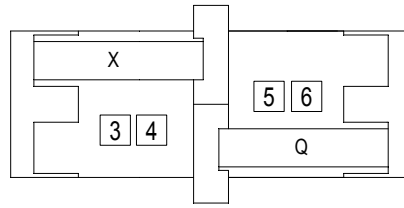
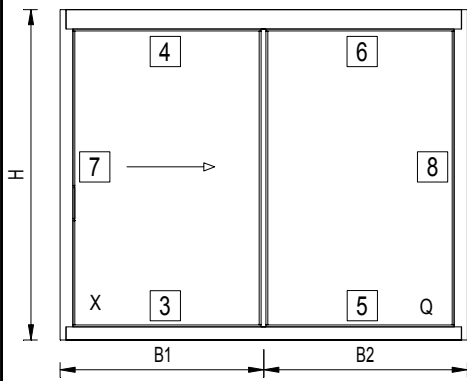

3

106.1394.XX

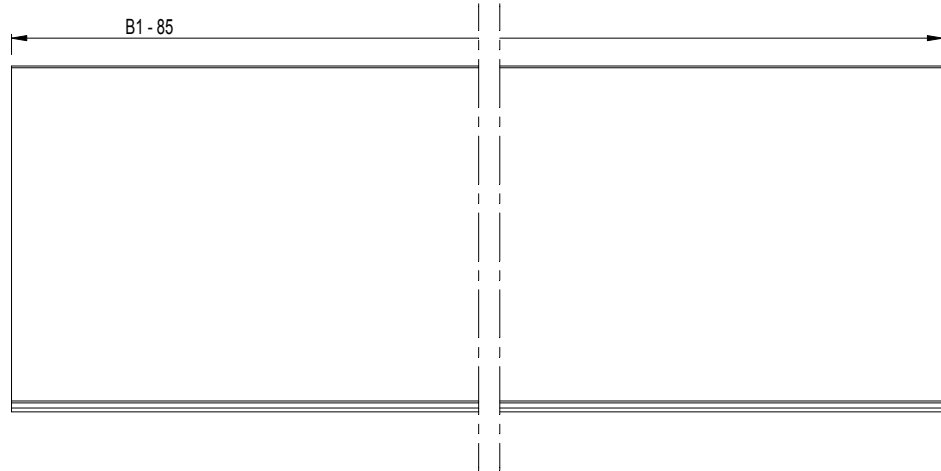

4

106.1394.XX

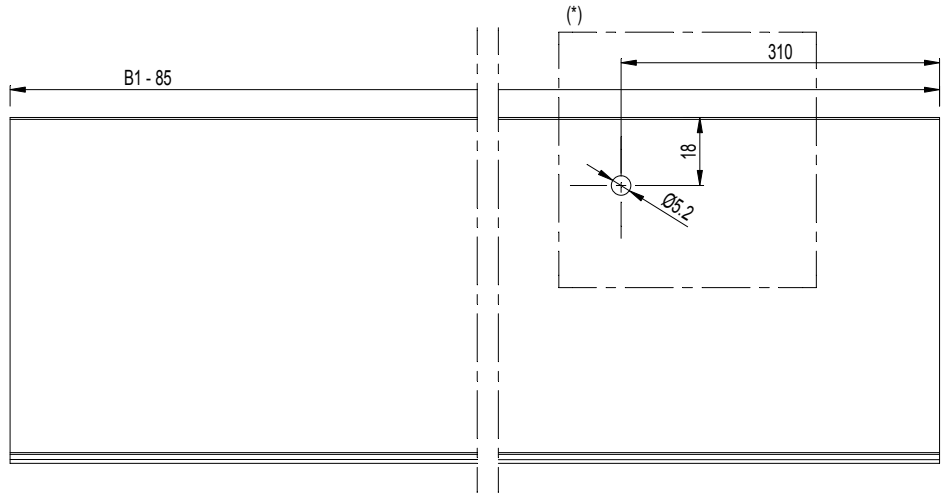

5 + 6

106.1395.XX

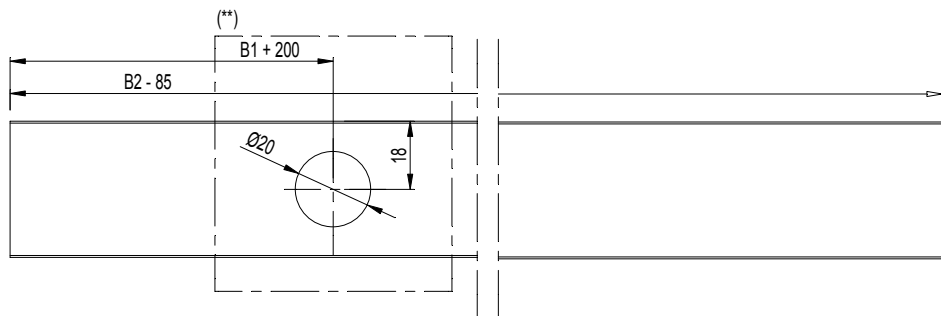

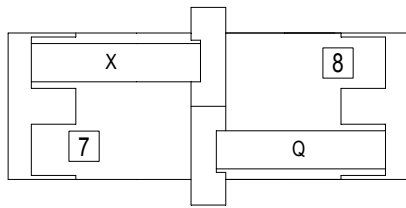

(\*) ENKEL VOOR MANUELE CONFIGURATIE  
 UNIQUEMENT POUR CONFIGURATION MANUELE  
 ONLY FOR MANUAL CONFIGURATION  
 NUR FUER MANUELE KONFIGURA

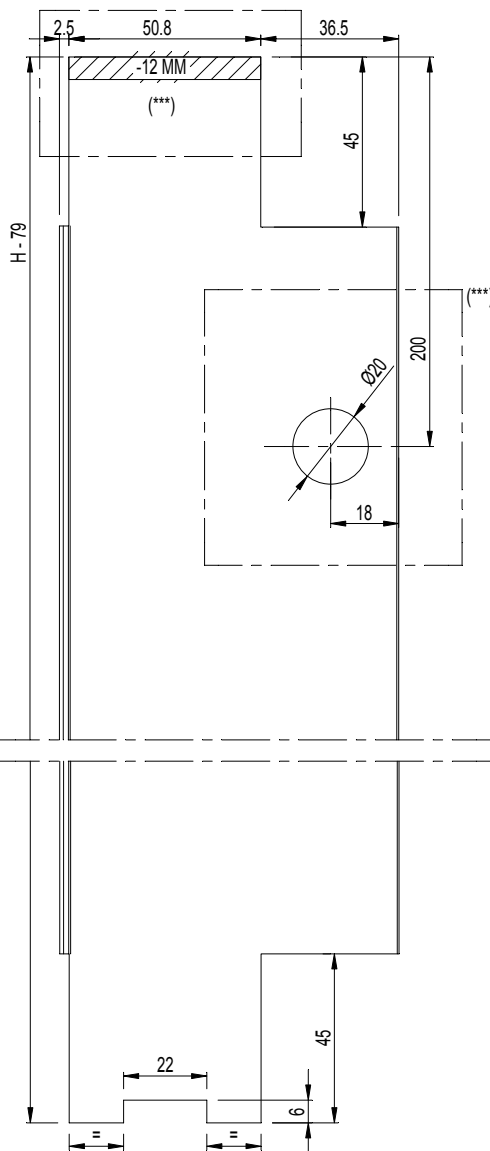
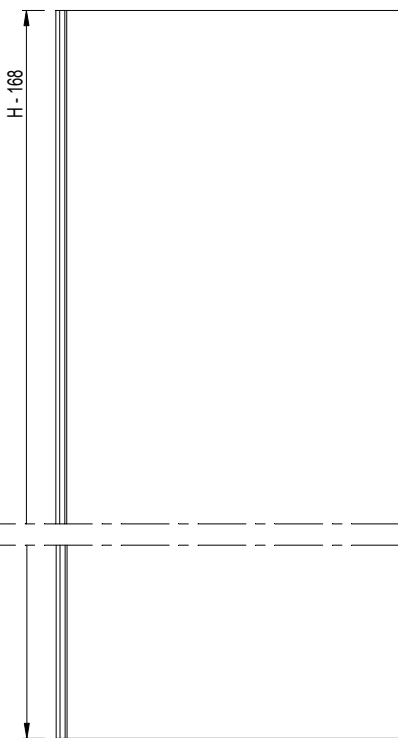
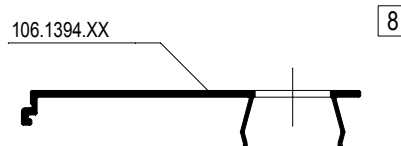
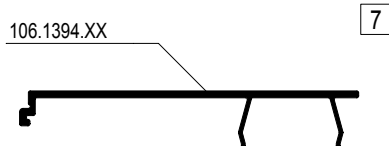
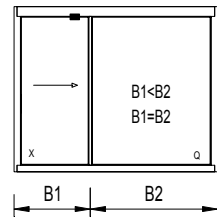

(\*\*) ENKEL VOOR MOTORISCHE CONFIGURATIE  
 UNIQUEMENT POUR CONFIGURATION MOTEUR  
 ONLY FOR MOTOR CONFIGURATION  
 NUR FUER MOTOR KONFIGURA

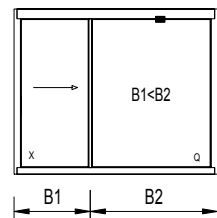

(\*\*\*) ENKEL VOOR MOTORISCHE CONFIGURATIE  
 UNIQUEMENT POUR CONFIGURATION MOTEUR  
 ONLY FOR MOTOR CONFIGURATION  
 NUR FUER MOTOR KONFIGURA

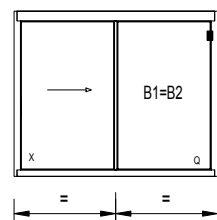

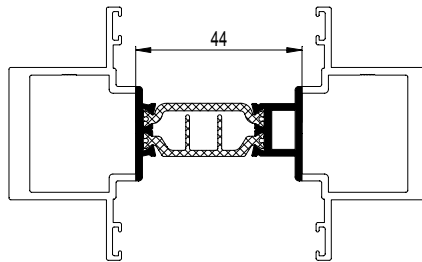
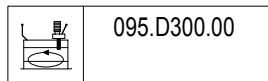
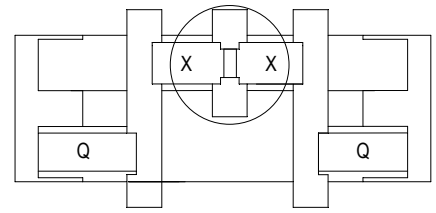
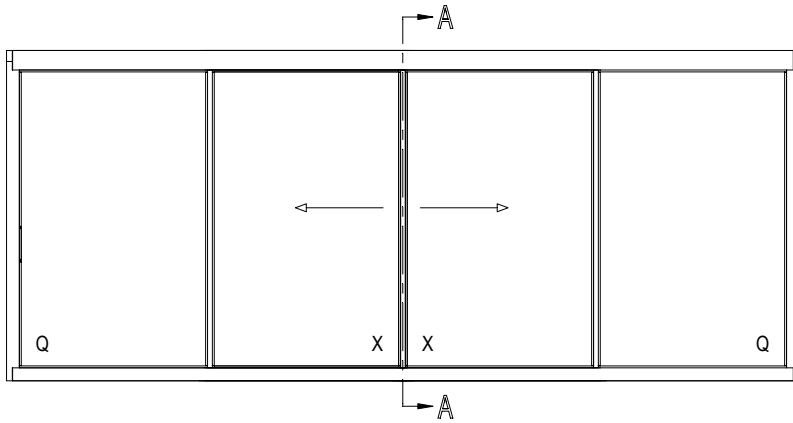

A - A

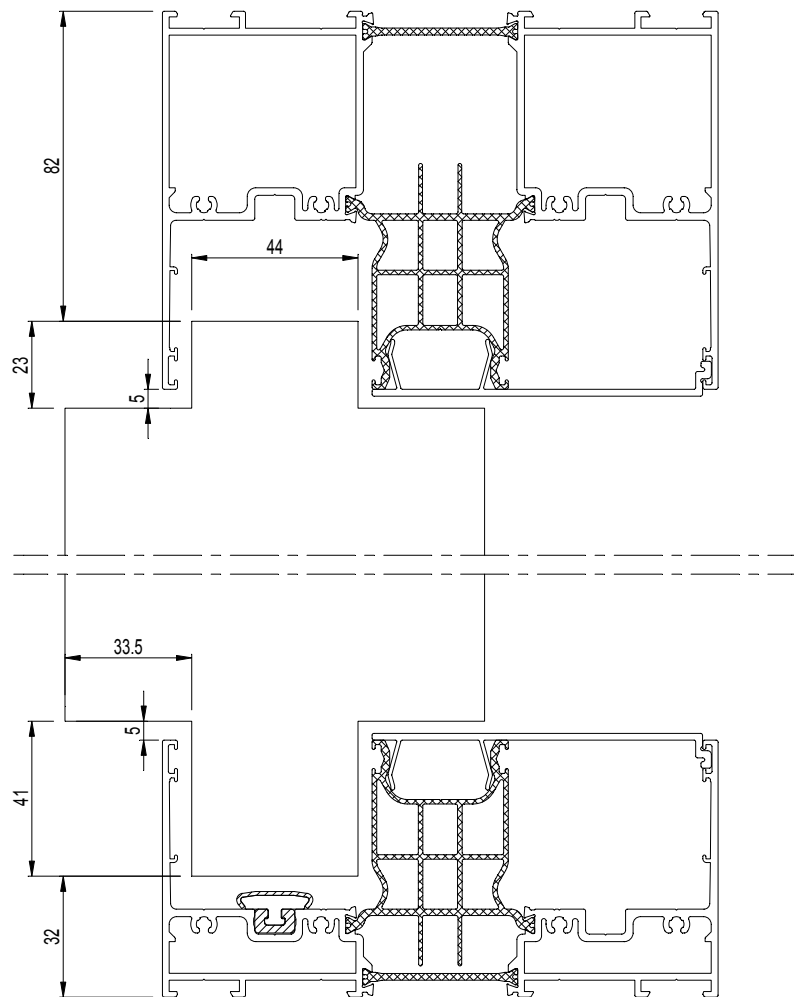

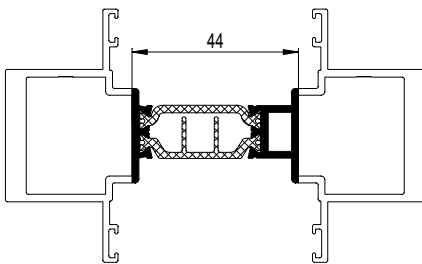
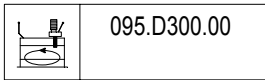

106.0397.XX

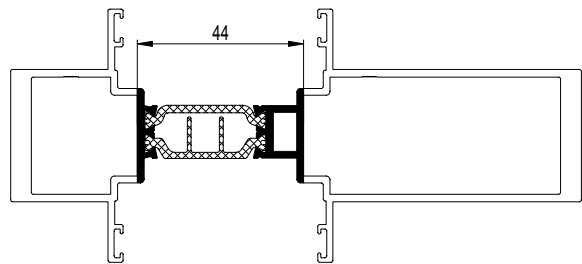
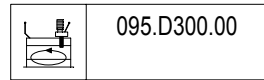

106.0398.XX

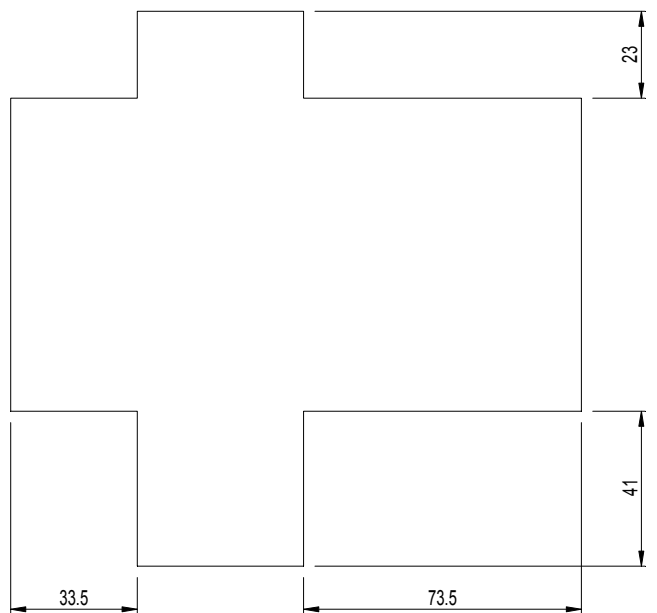
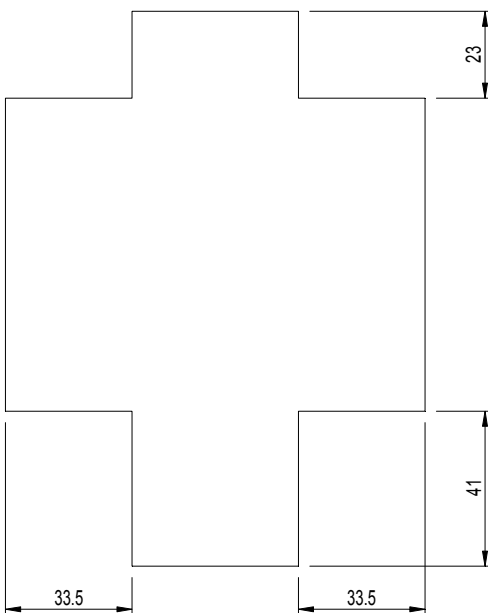

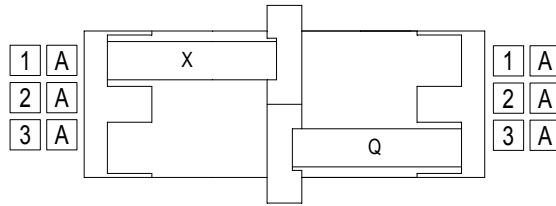
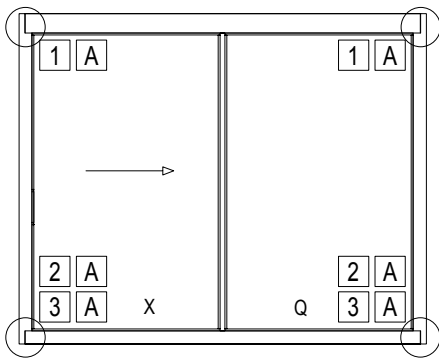

**!** METHODE 1.  
 METHODE 1.  
 METHOD 1.  
 METHODE 1.

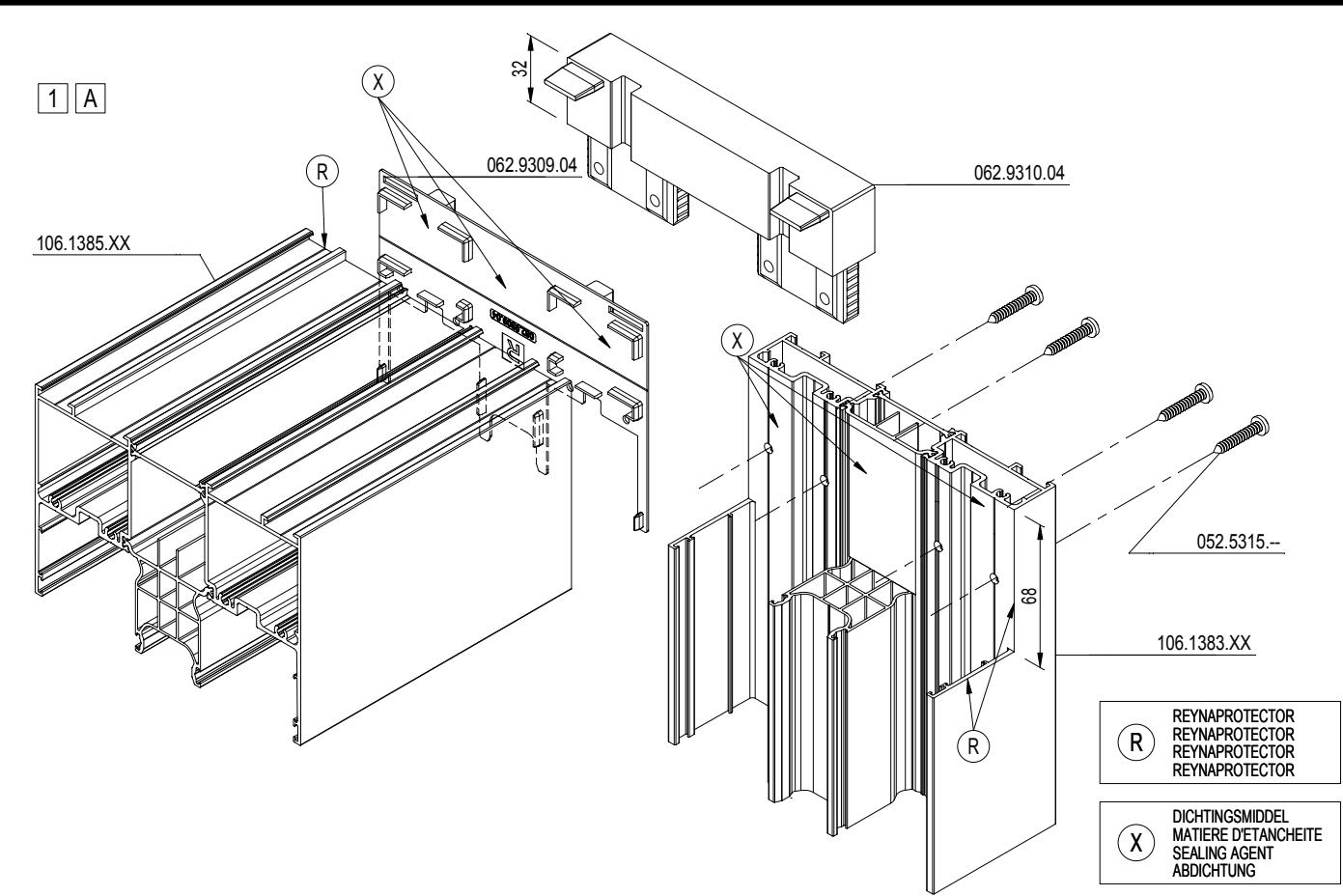
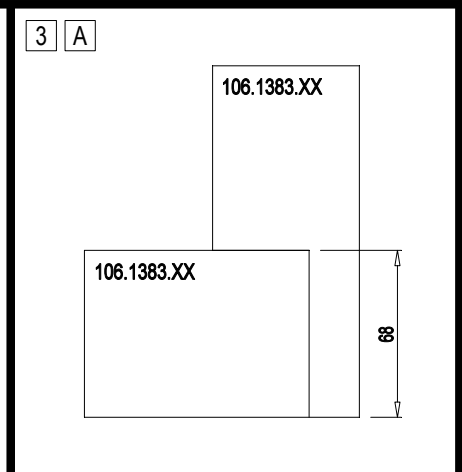
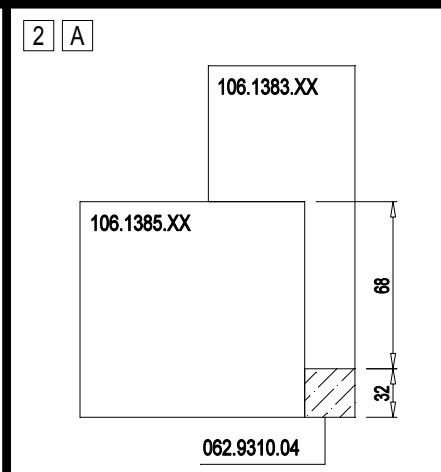
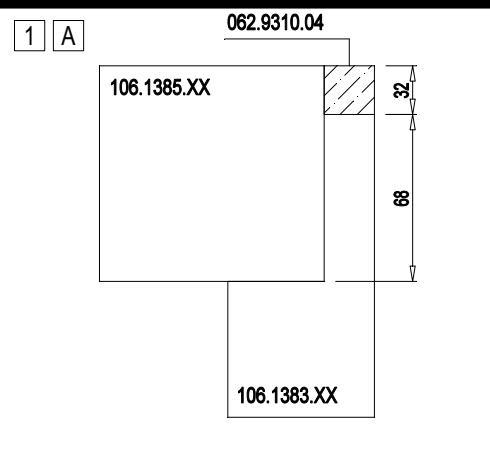

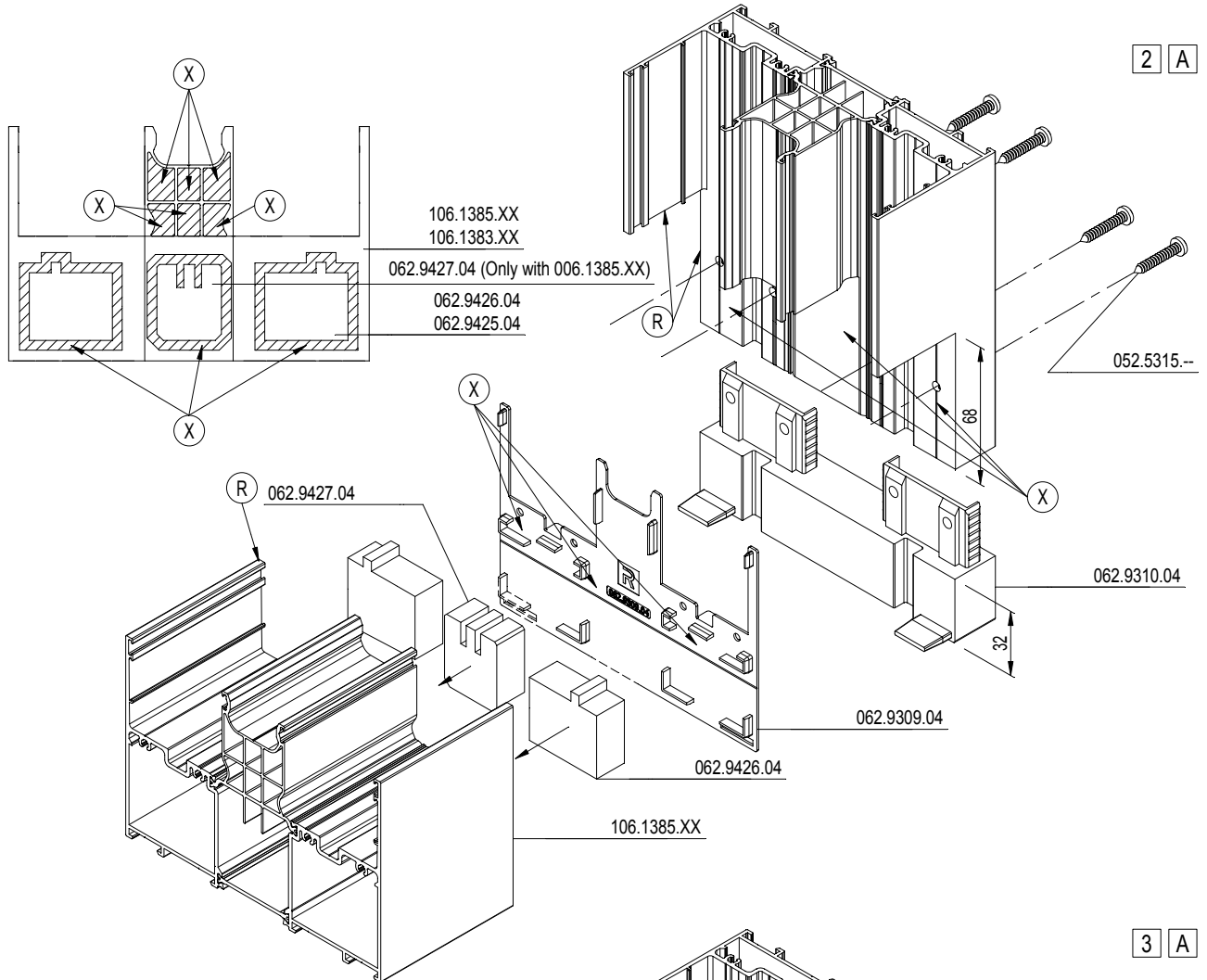

2 A

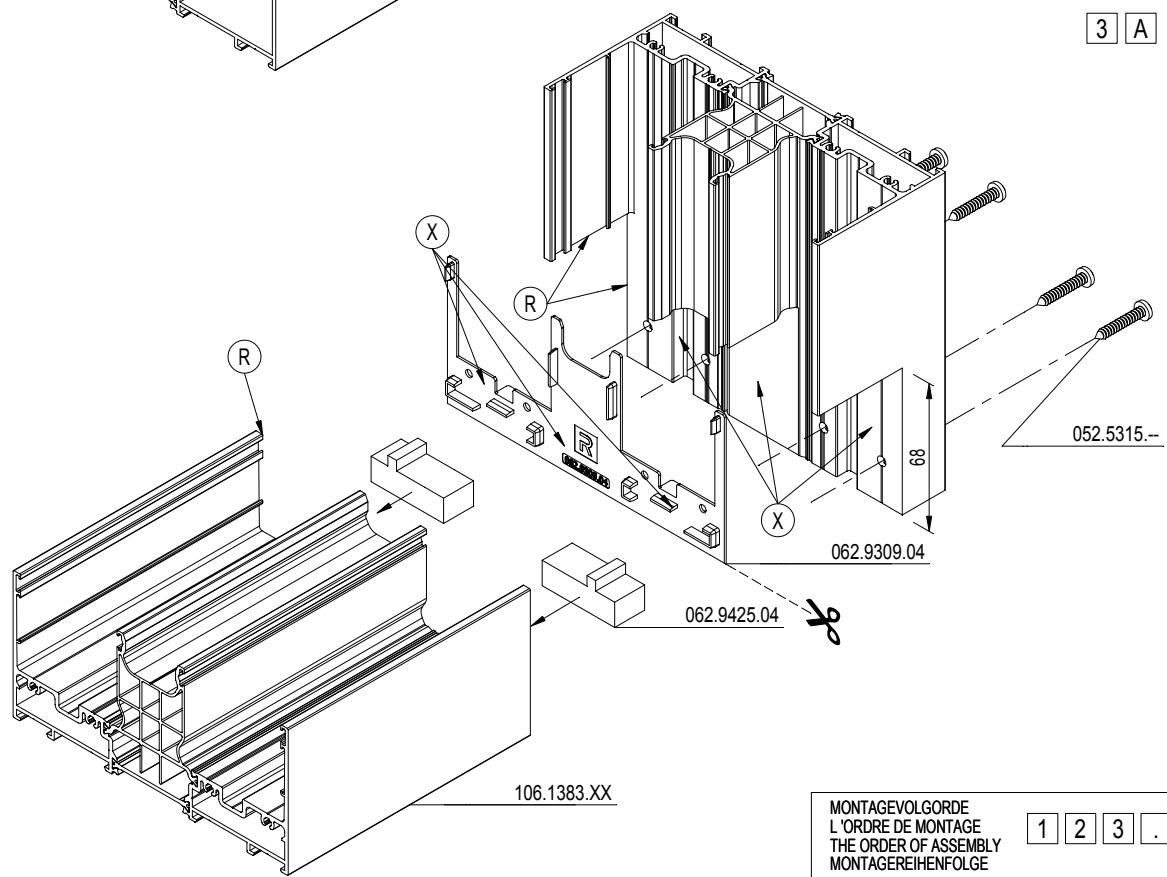

3 A

MONTAGEVOLGORDE	L'ORDRE DE MONTAGE	THE ORDER OF ASSEMBLY	MONTAGEREIHENFOLGE
1	2	3	.

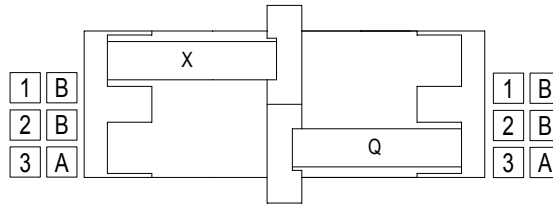
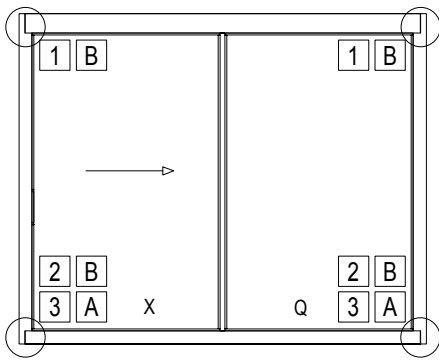

METHODE 2.  
 METHODE 2.  
 METHOD 2.  
 METHODE 2.

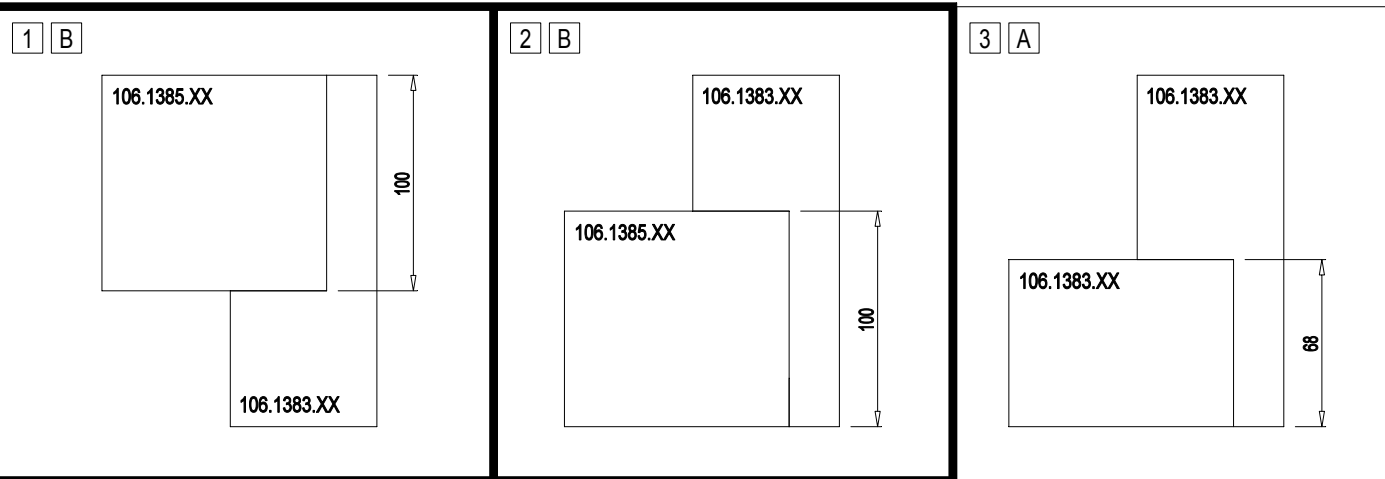

(R) REYNAPROTECTOR  
 REYNAPROTECTOR  
 REYNAPROTECTOR  
 REYNAPROTECTOR

(X) DICHTINGSMIDDEL  
 MATIERE D'ETANCHEITE  
 SEALING AGENT  
 ABDICHTUNG

D0093184



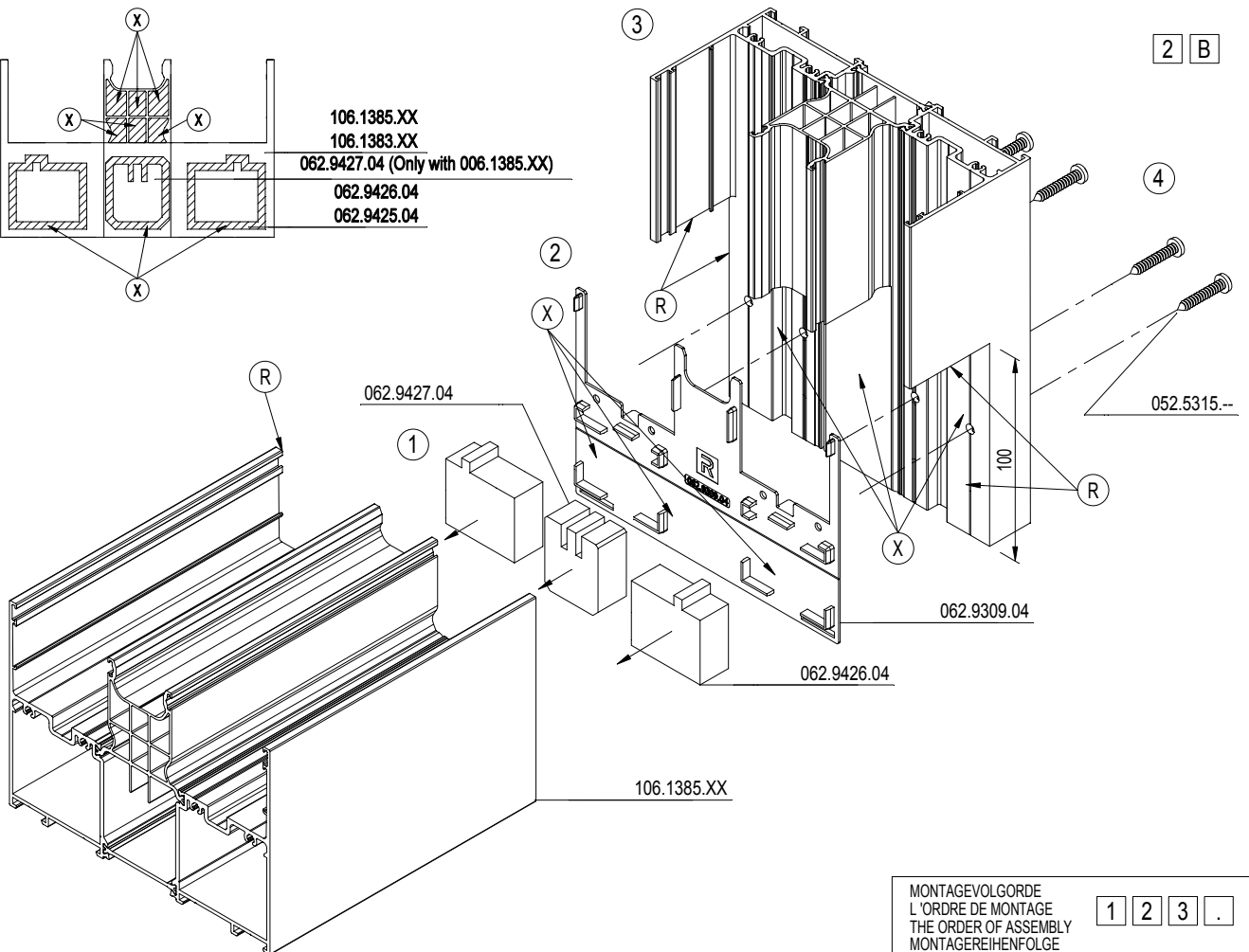
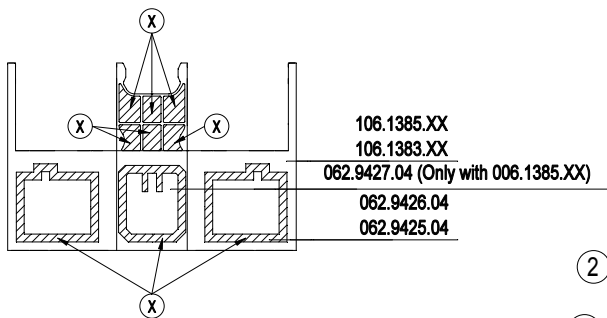
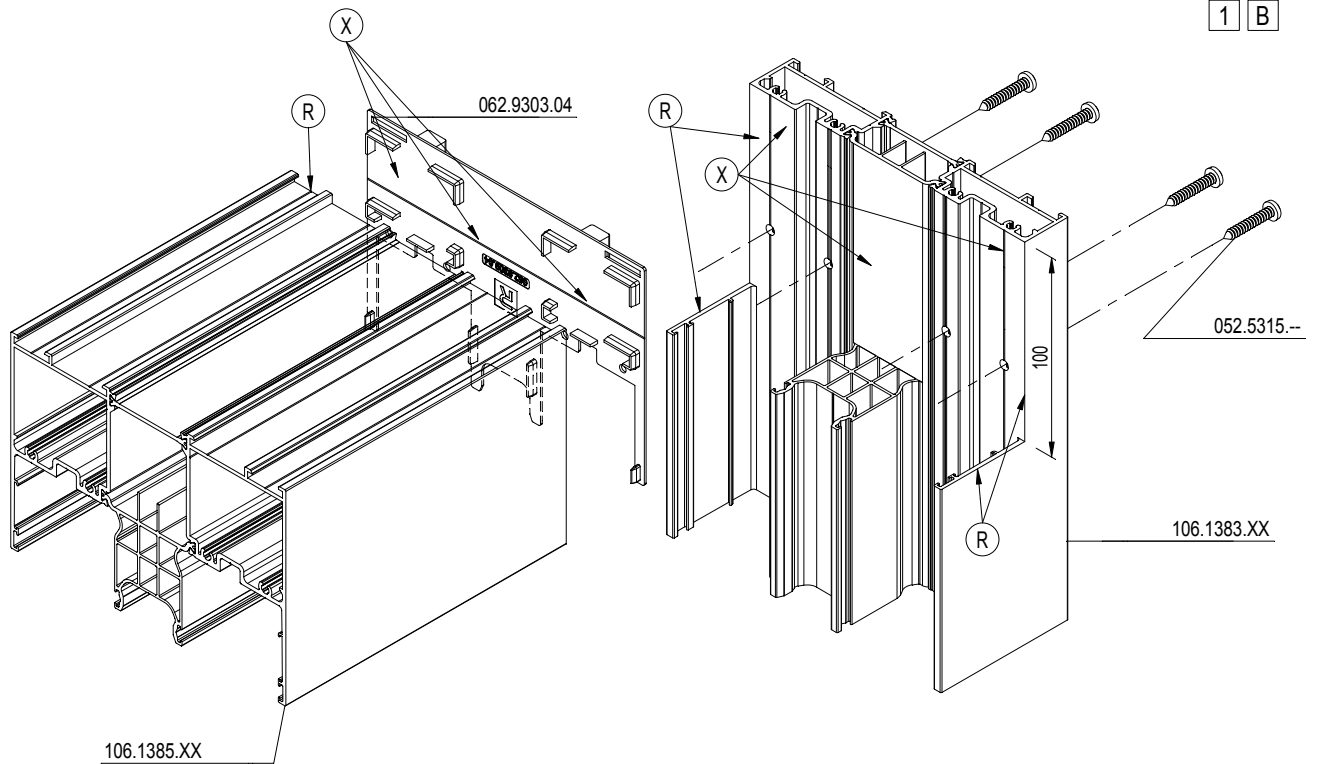

MONTAGEVOLGORDE	1	2	3	.
L'ORDRE DE MONTAGE				
THE ORDER OF ASSEMBLY				
MONTAGEREIHENFOLGE				

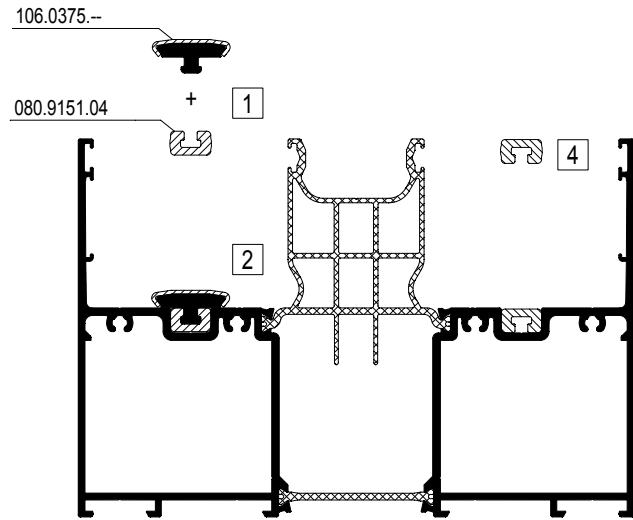
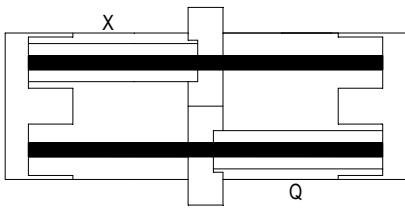
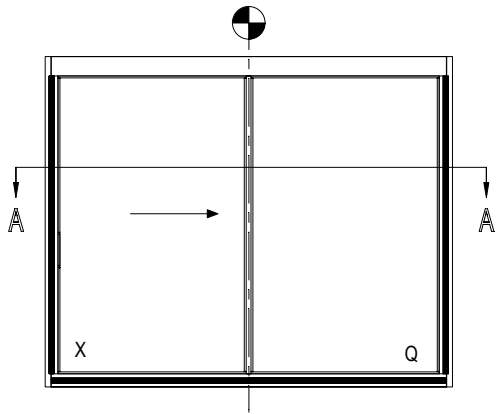

A - A

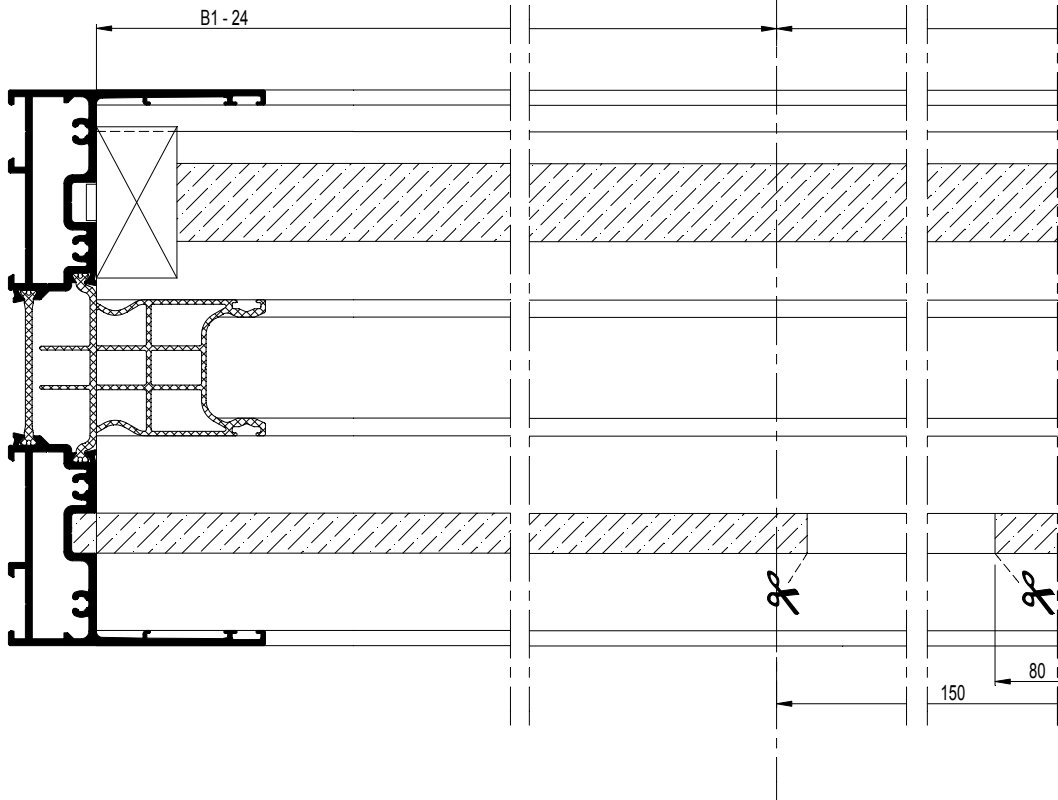

**!** ONDERBREEK TER HOOGTE VAN DE STEUNBLOKKEN.  
INTERROMPEZ A L'HAUTEUR DU CALES DE SUPPORT.  
CUT THE GASKET AT THE SUPPORT PIECES.  
UNTERBRECHEN AUF DER HOEHE STUETZKLOTZEN.

D0093182

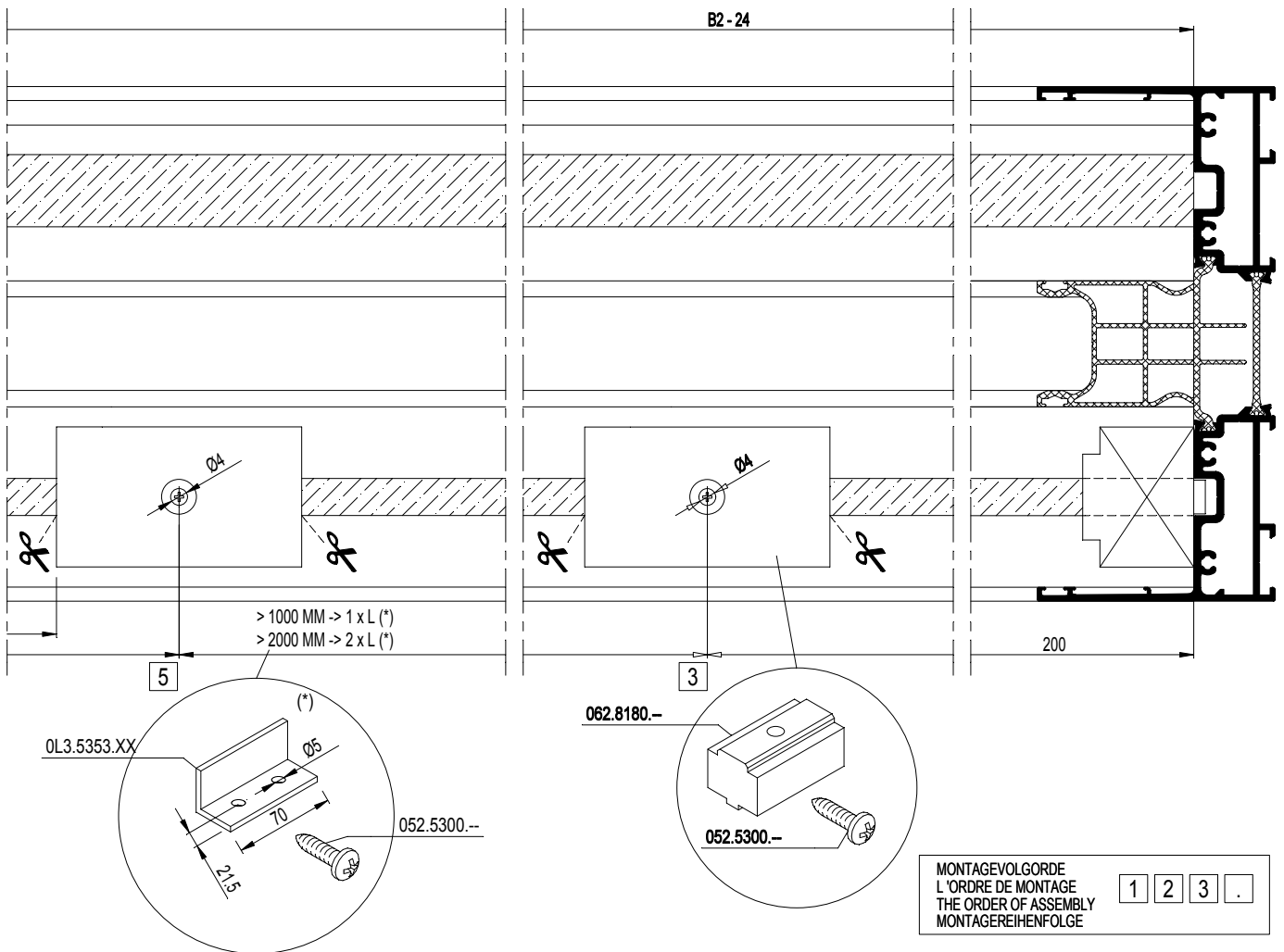
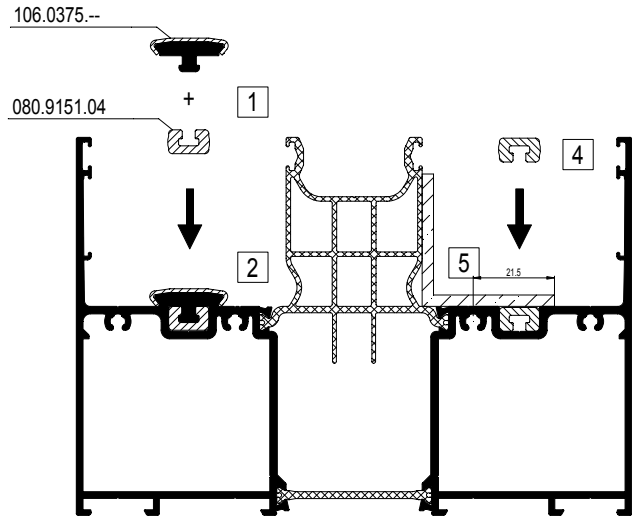
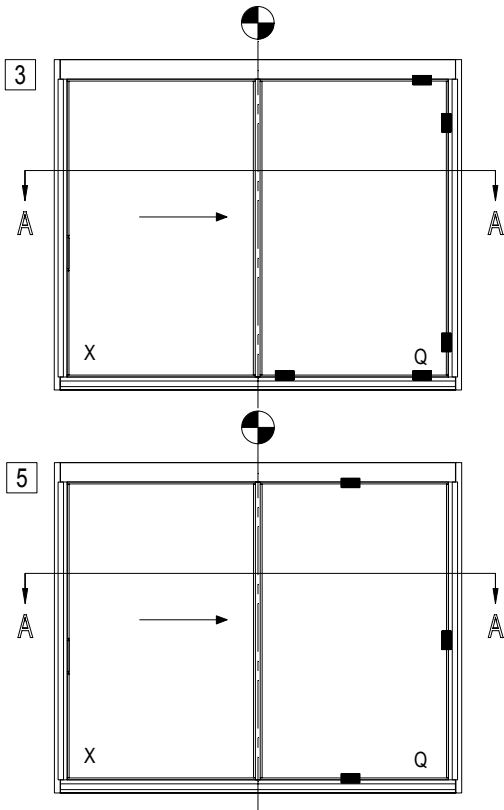

MONTAGEVOLGORDE  
L'ORDRE DE MONTAGE  
THE ORDER OF ASSEMBLY  
MONTAGEREIHENFOLGE

1	2	3	.
---	---	---	---

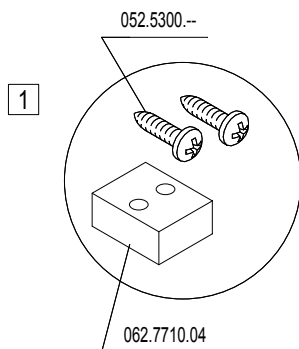
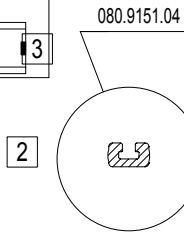
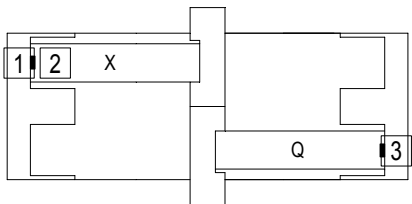
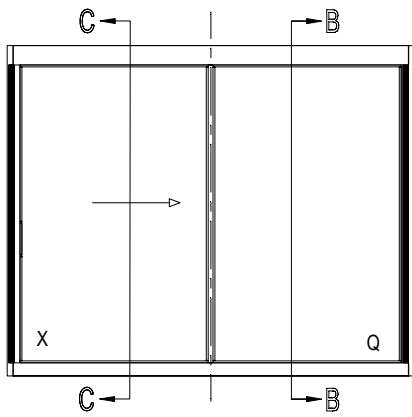

C-C

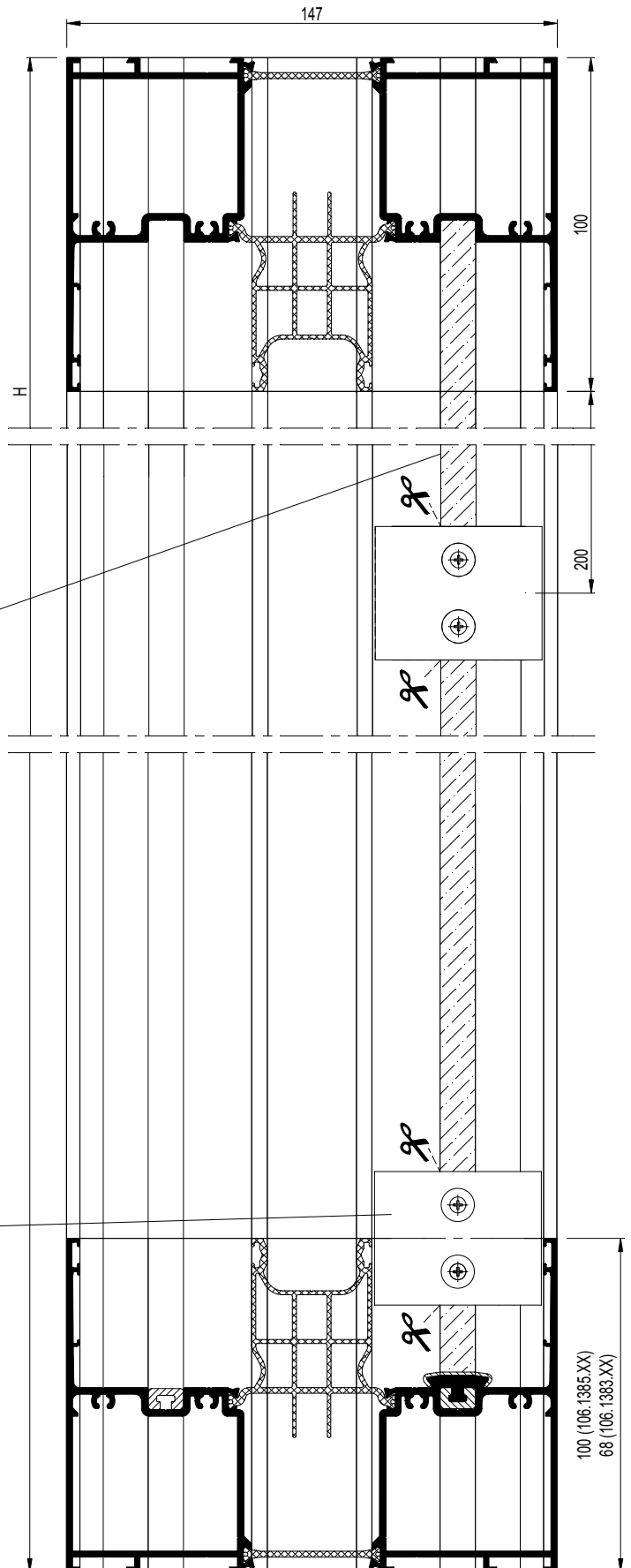

**!** ONDERBREEK TER HOOGTE VAN DE STEUNBLOKKEN.  
INTERROMPEZ A L'HAUTEUR DU CALES DE SUPPORT.  
CUT THE GASKET AT THE SUPPORT PIECES.  
UNTERBRECHEN AUF DER HOEHE STUETZKLOTZEN.

B - B

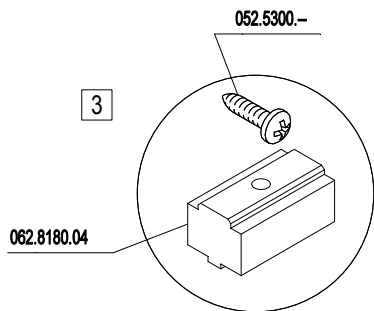
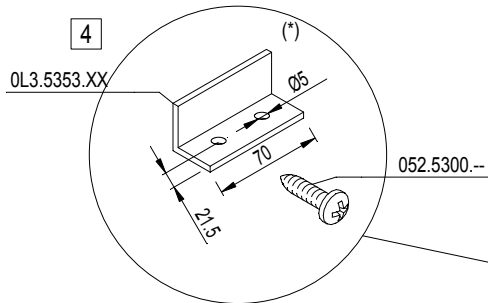
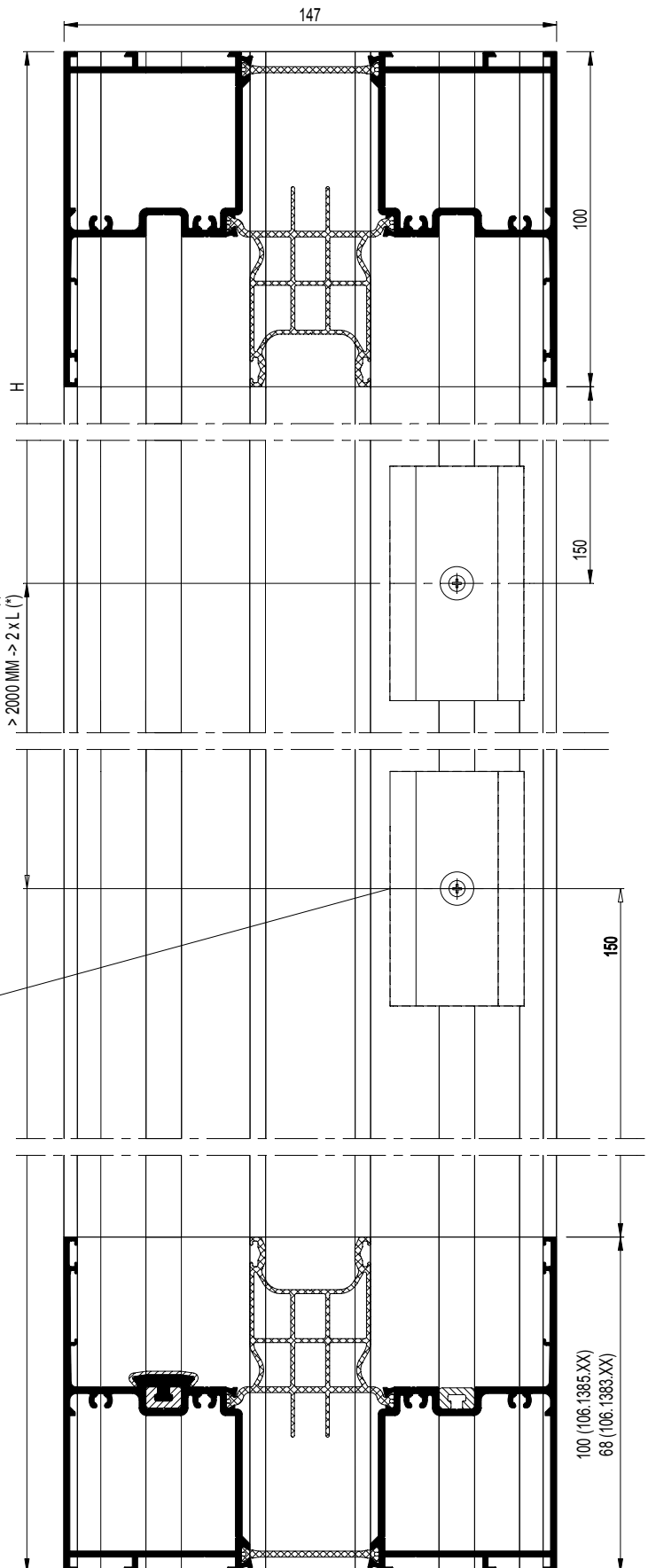

MONTAGEVOLGORDE  
L'ORDRE DE MONTAGE  
THE ORDER OF ASSEMBLY  
MONTAGEREIHENFOLGE

1	2	3	.
---	---	---	---

D0093188

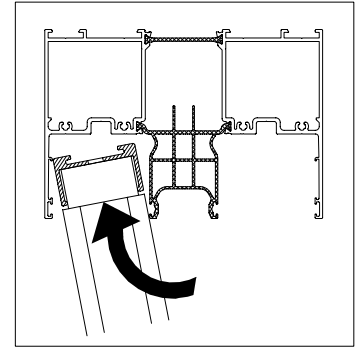
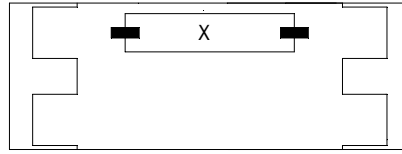
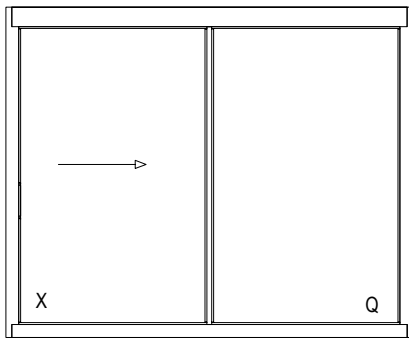

**1** STEUNBLOKKEN PLAATSEN OP ONGEVEER 1/4 en 3/4 VAN DE BREEDTE VAN HET ELEMENT  
 PLACER DES CALES DE VITRAGE A ENVIRON 1/4 ET 3/4 DE LA LARGEUR DE L'ELEMENT  
 POSITION SUPPORT PIECES AT APPROXIMATELY 1/4 AND 3/4 OF THE WIDTH OF THE ELEMENT  
 STUETZKLOETZE BEI UNGEFÄHR 1/4 UND 3/4 DER BREITE DES ELEMENTS ANBRINGEN

**2** VLEUGEL OMHOOG IN KADER SCHUIVEN  
 GLISSER L'OUVRANT VERS LE HAUT DANS LE DORMANT  
 SLIDE VENT UPWARDS INTO FRAME  
 FLUEGEL NACH OBEN IN RAHMEN SCHIEBEN

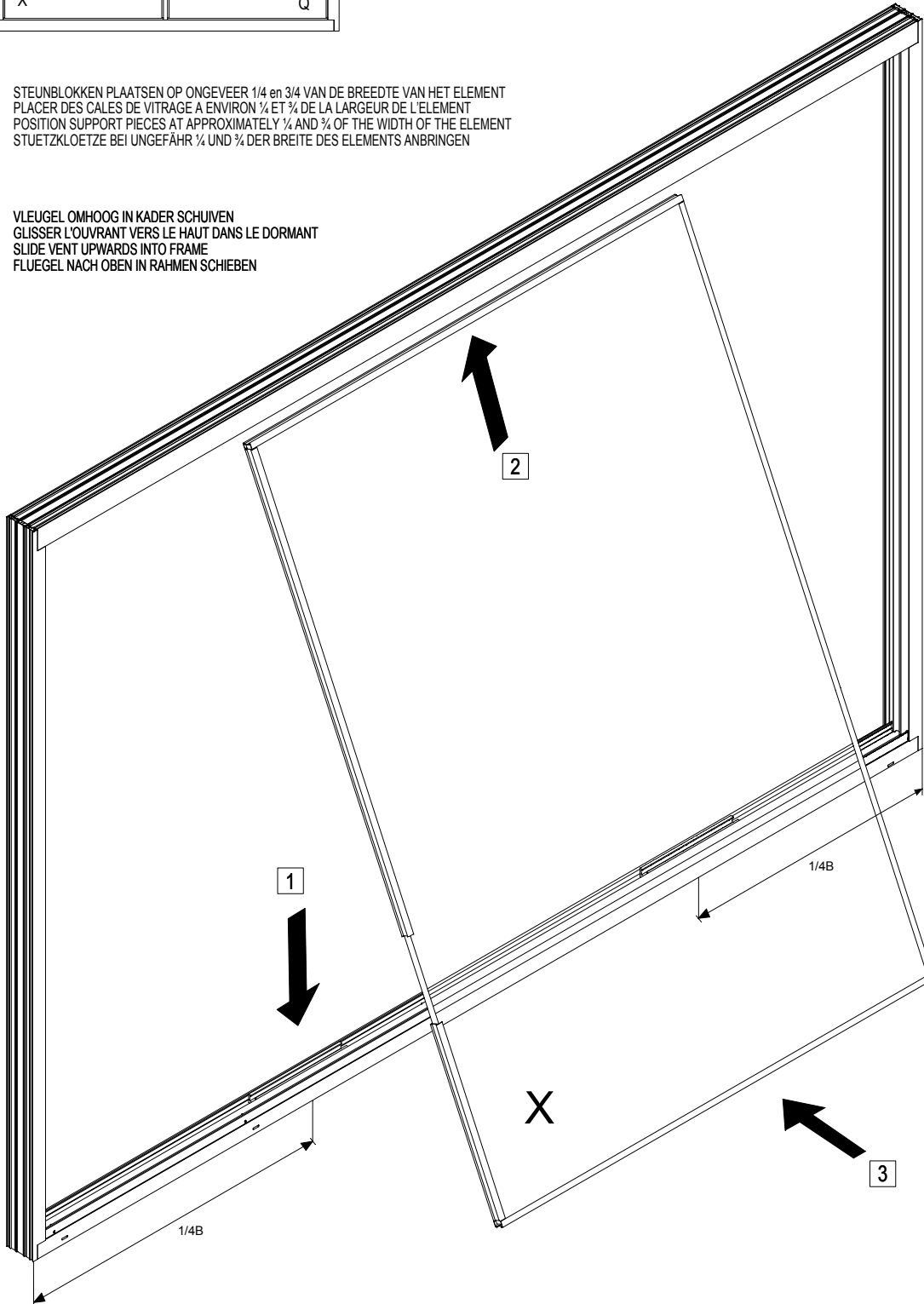

- 4 VLEUGEL LATEN ZAKKEN OP BLOKKEN  
 FAIRE DESCENDRE L'OUVRANT SUR LES CALES  
 LOWER VENT ONTO BLOCKS  
 FLUEGEL AUF KLOETZE SINKEN LASSEN

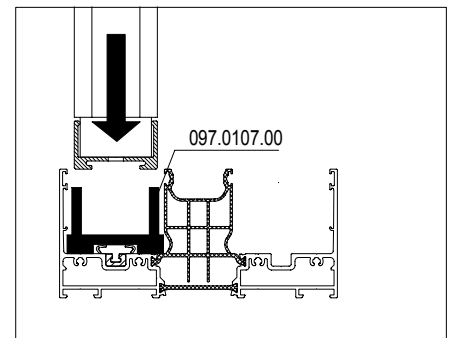
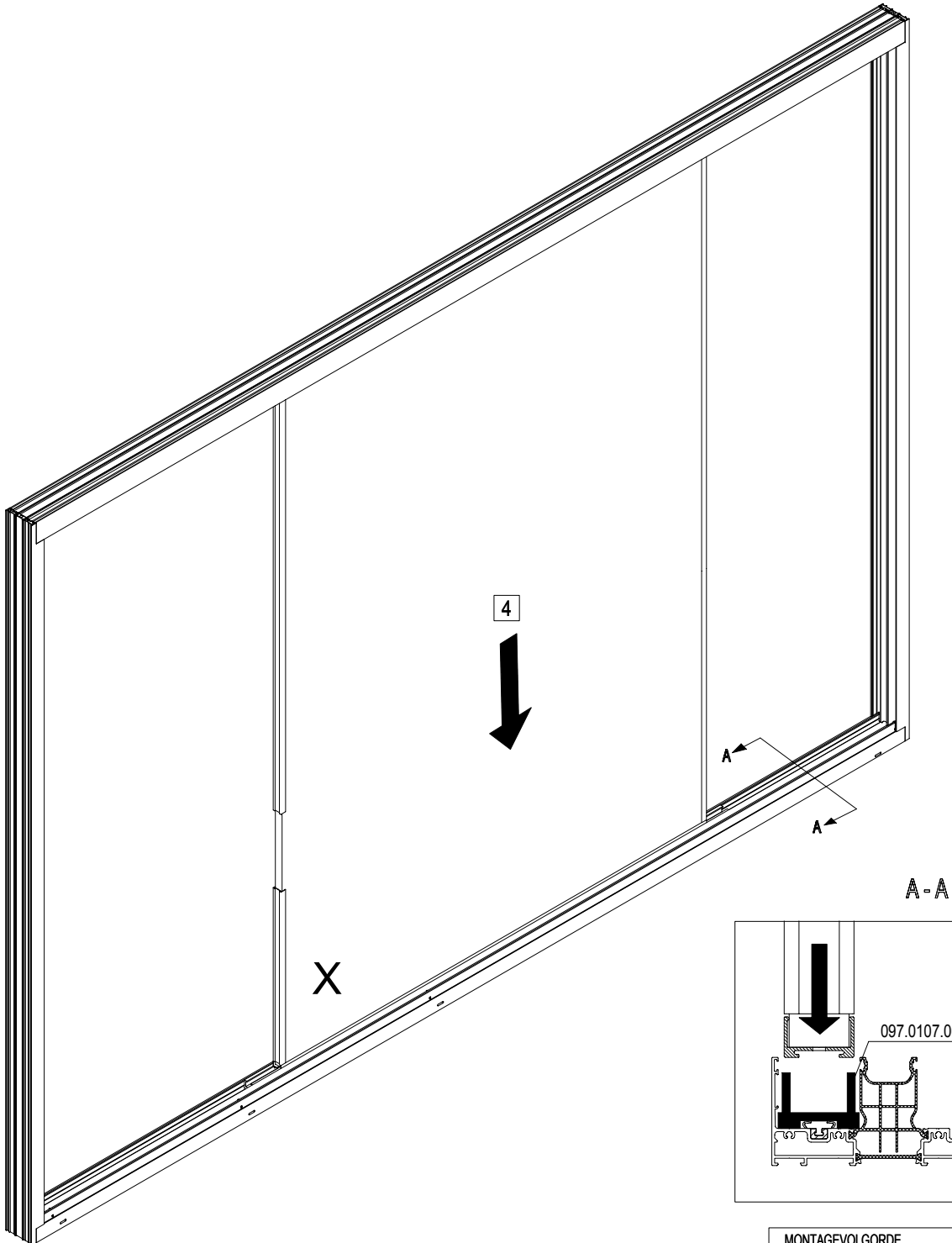

MONTAGEVOLGORDE L'ORDRE DE MONTAGE THE ORDER OF ASSEMBLY MONTAGEREIHENFOLGE	1	2	3	.
--	---	---	---	---

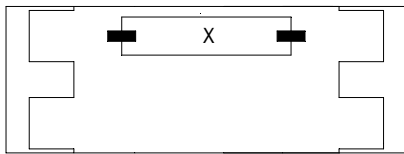
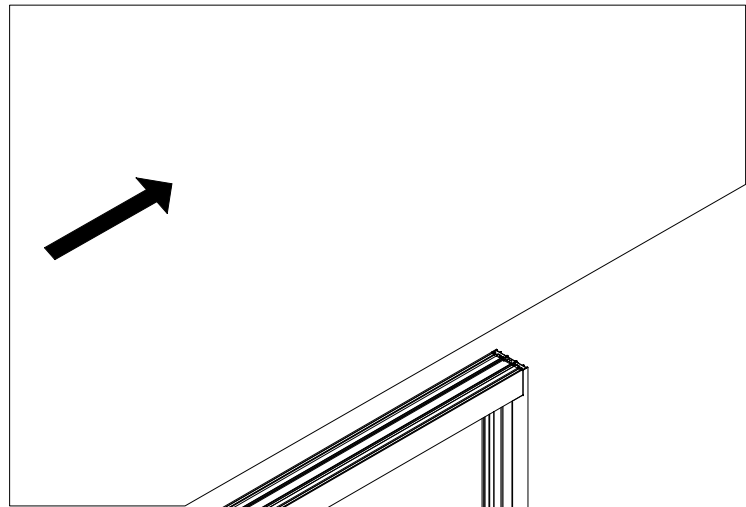
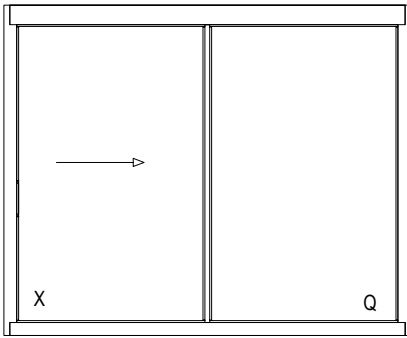

**1** WIELEN ONDER VLEUGEL SCHUIVEN  
 GLISSER DES ROULETTES SOUS L'OUVRANT  
 SLIDE WHEELS UNDER VENT  
 RAEDER UNTER FLUEGEL SCHIEBEN

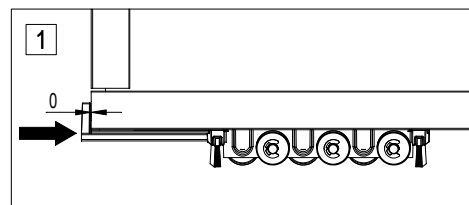
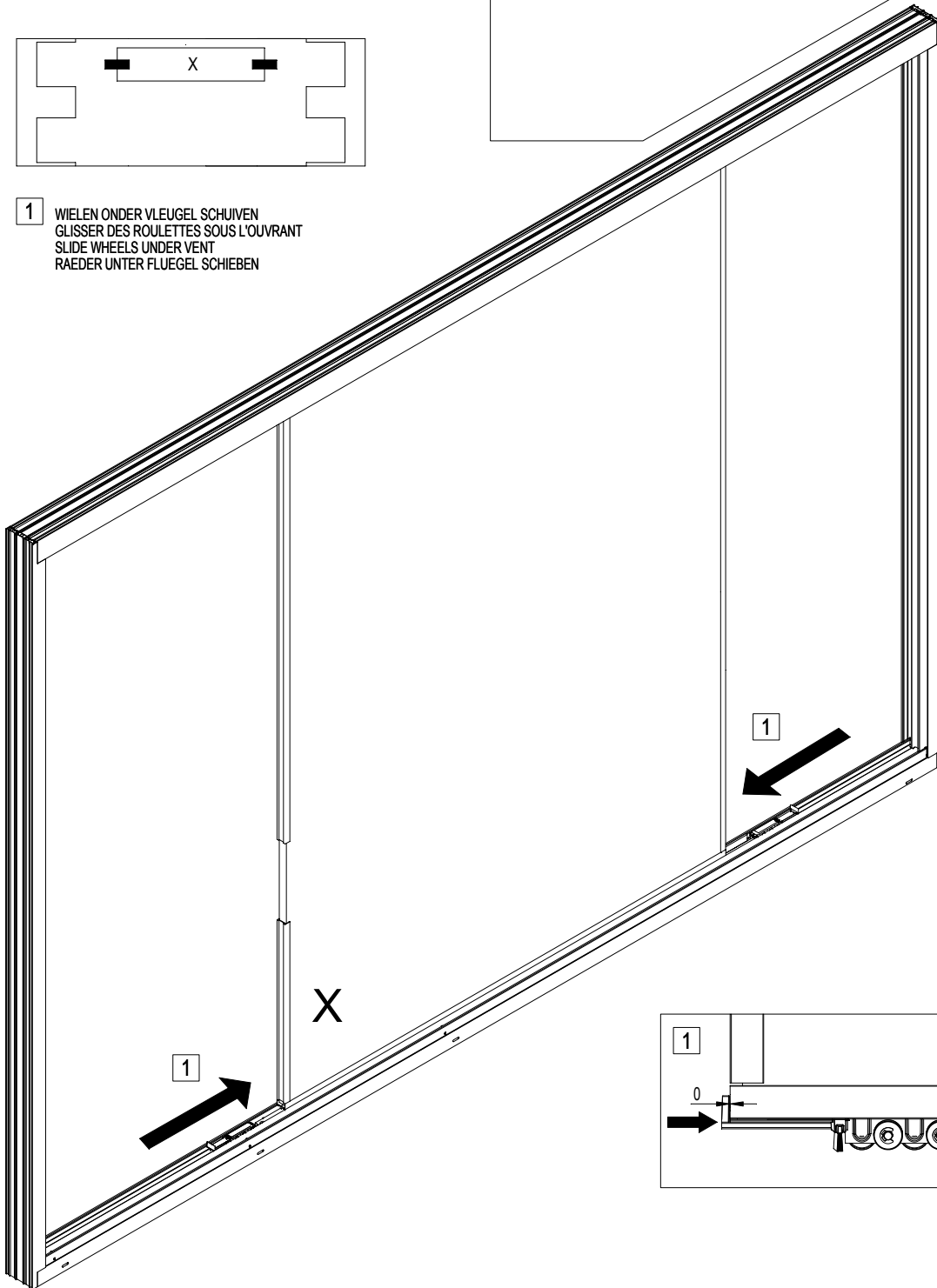



- 2 3** VLEUGEL OMHOOG HEFFEN EN BLOKKEN ONDERUIT SCHUIVEN  
 LEVER L'OUVRANT VERS LE HAUT ET GLISSER DES CALES EN DESSOUS  
 LIFT VENT UP AND SLIDE BLOCKS OUT  
 FLUEGEL ANHEBEN UND KLOETZE DARUNTER HERAUSSCHIEBEN

- 4** VLEUGEL OP WIELEN LATEN ZAKKEN  
 LAISSER DESCENDRE L'OUVRANT SUR LES ROULETTES  
 LOWER VENT ONTO WHEELS  
 FLUEGEL AUF RAEDER SINKEN LASSEN

- 5** VLEUGEL OP ZIJN UITERSTE POSITIE SCHUIVEN  
 FAIRE GLISSER L'OUVRANT DANS SA POSITION EXTREME  
 SLIDE VENT TO ITS LIMIT POSITION  
 FLUEGEL IN SEINE AUSSERSTE POSITION SCHIEBEN

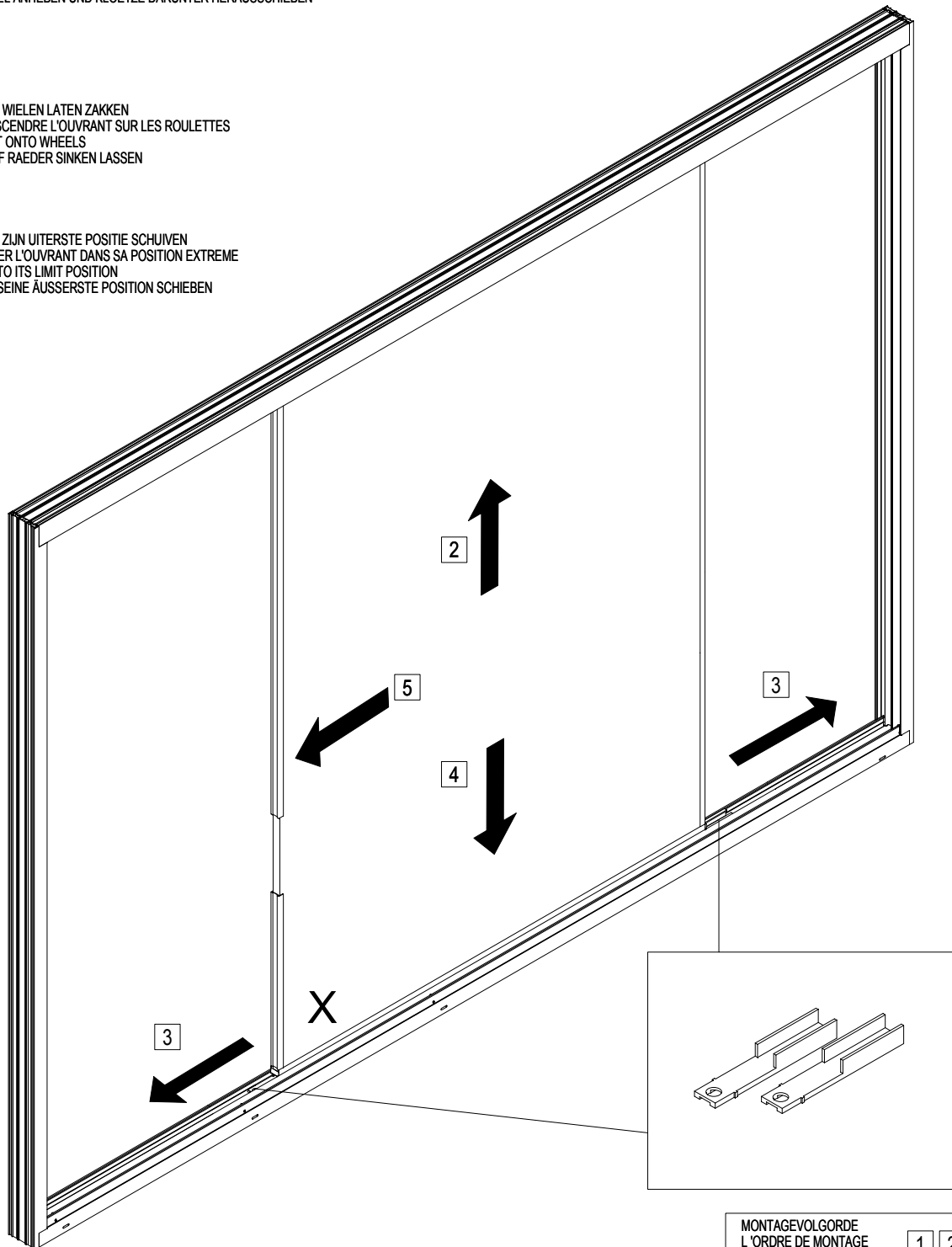

MONTAGEVOLGORDE  
 L'ORDRE DE MONTAGE  
 THE ORDER OF ASSEMBLY  
 MONTAGEREIHENFOLGE

1	2	3	.
---	---	---	---

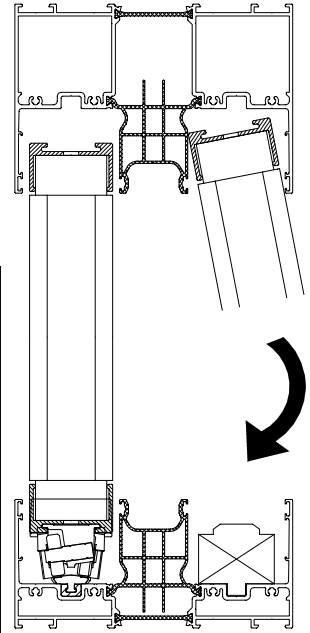
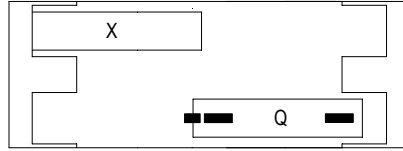
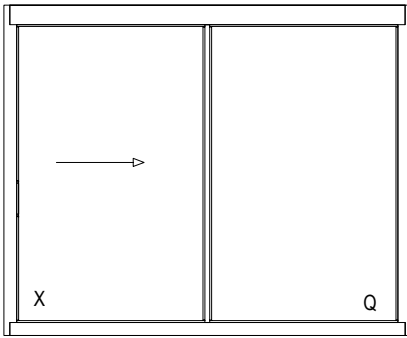

**1** VASTE VLEUGEL BOVENAAN IN KADER STEKEN  
 ENFONCER L'OUVRANT FIXE DANS LE DORMANT EN HAUT  
 PUSH FIXED VENT INTO FRAME AT TOP  
 FESTEN FLUEGEL OBEN IN RAHMEN STECKEN

**2** VLEUGEL NAAR BINNEN DUWEN EN LATEN ZAKKEN OP BLOKKEN  
 POUSSER L'OUVRANT VERS L'INTERIEUR ET LE LAISSER DESCENDRE SUR DES CALES  
 PUSH VENT INWARDS AND LOWER ONTO BLOCKS  
 FLUEGEL NACH INNEN DRUECKEN UND AUF KLOETZE SINKEN LASSEN

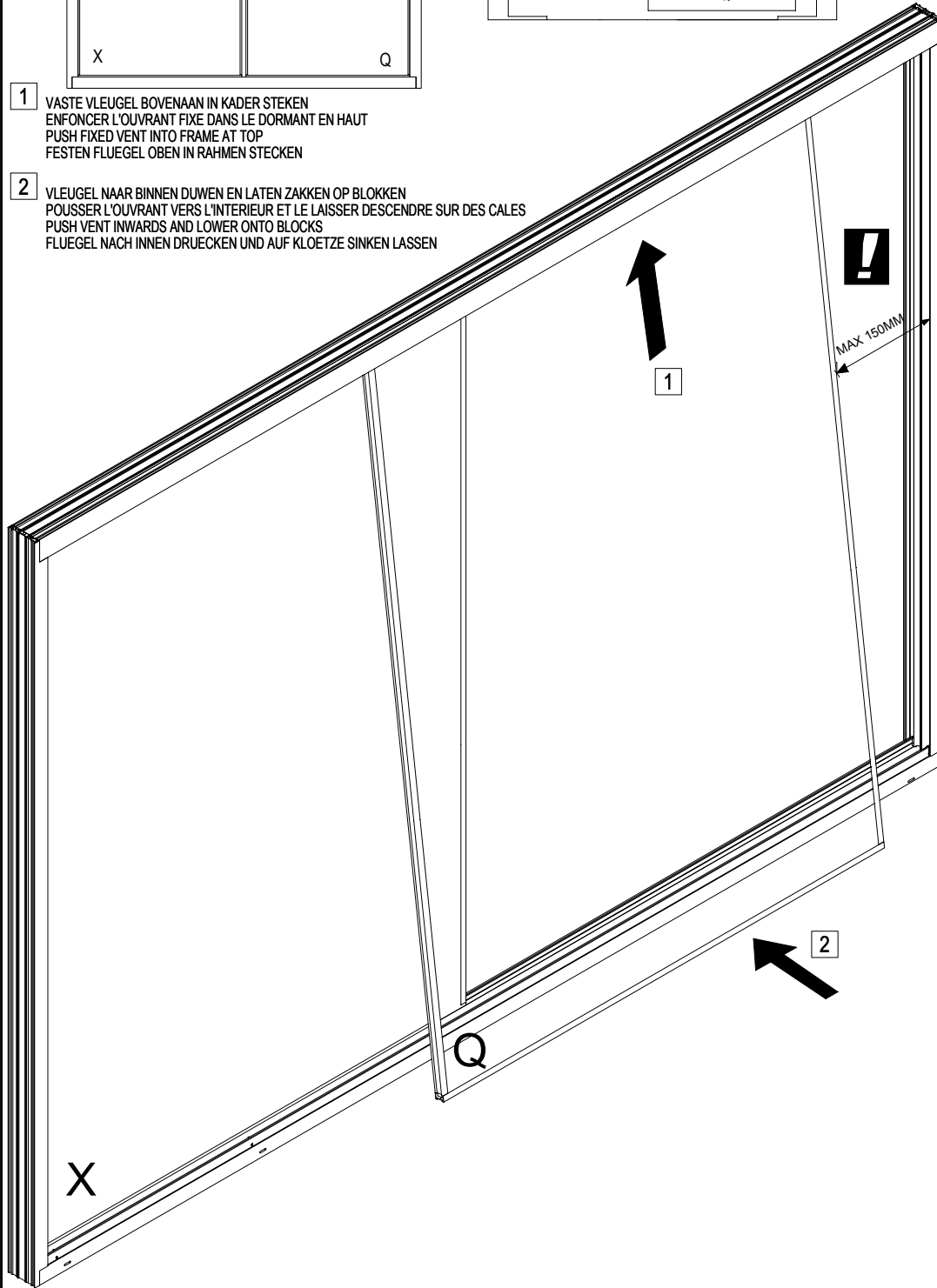

**3** VLEUGEL OP UITERSTE POSITIE SCHUIVEN  
 FAIRE GLISSER L'OUVRANT DANS SA POSITION EXTREME  
 SLIDE VENT TO ITS LIMIT POSITION  
 FLUEGEL IN SEINE AUSSERSTE POSITION SCHIEBEN

**4** FIXATIEBLOKKEN MONTEREN BOVEN EN BENEDEN : 062.8182.00  
 MONTER DES CALES DE FIXATION EN HAUT ET EN BAS : 062.8182.00  
 MOUNT FIXING BLOCKS TOP AND BOTTOM : 062.8182.00  
 FIXIERKLOETZE OBEN UND UNTEN MONTIEREN : 062.8182.00

**5** SCHROEFKOPPEN UITBOREN  
 FRAISER LES TETES DE VIS (OU ETAPE 6 AVEC DES VIS ANTI-EFFRACTION)  
 DRILL OUT SCREW HEADS (OR STEP 6 WITH BURGLAR PROTECTION SCREWS)  
 SCHRAUBENKÖPFE AUSBOHREN (ODER SCHRITT 6 MIT EINBRUCHHEMMENDEN SCHRAUBEN)

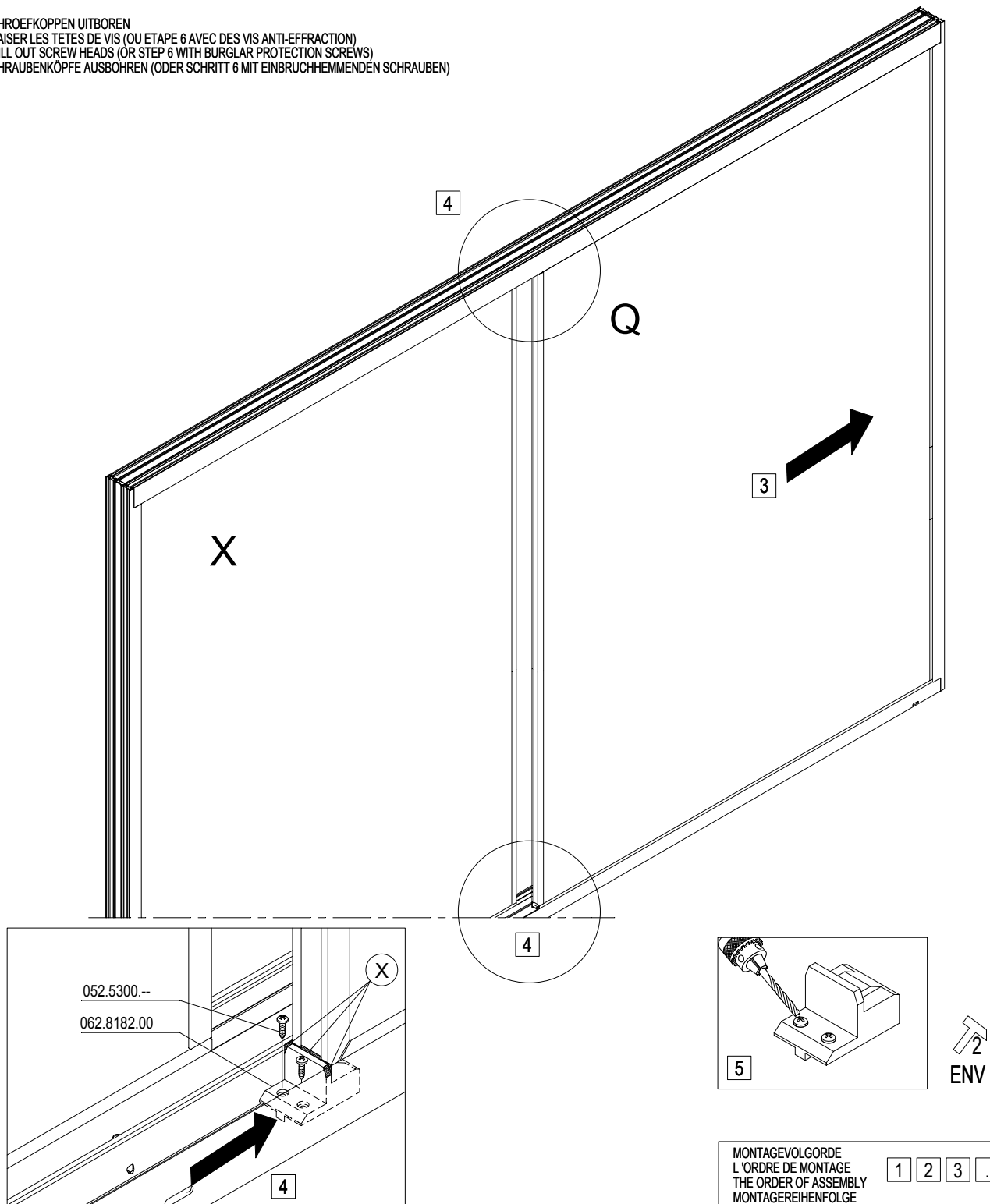

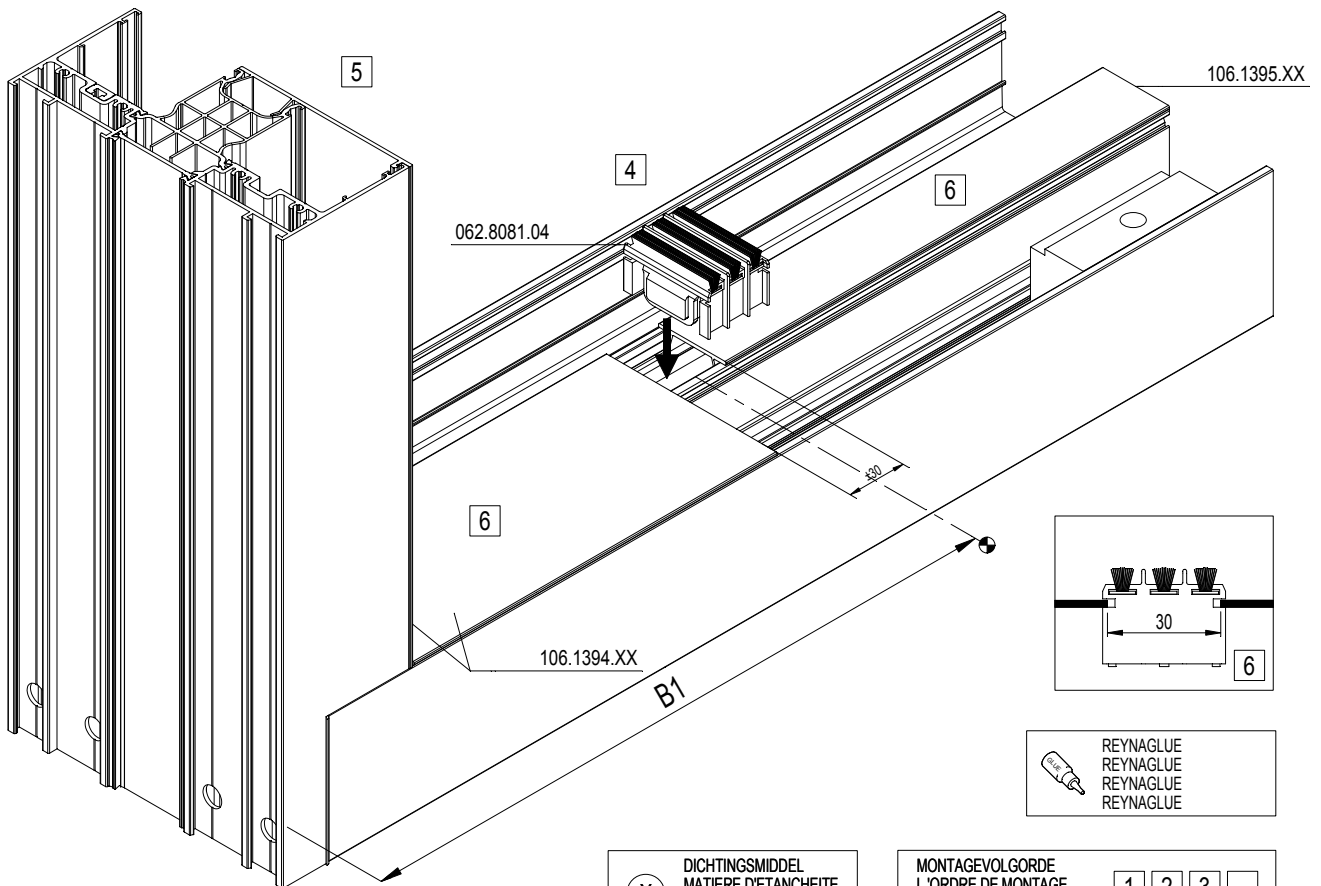
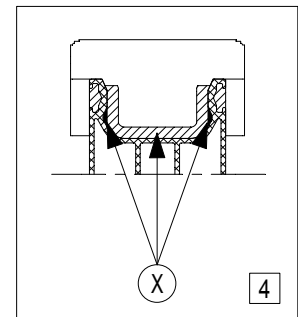
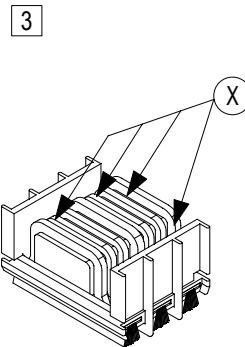
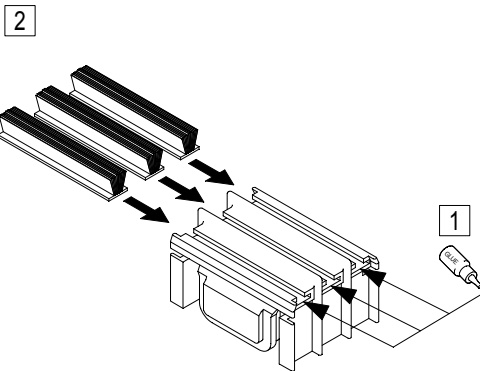
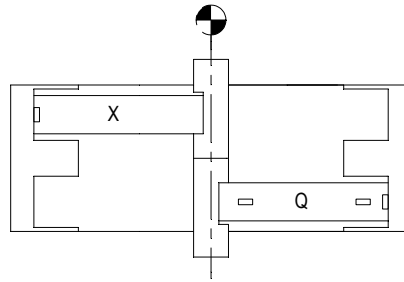
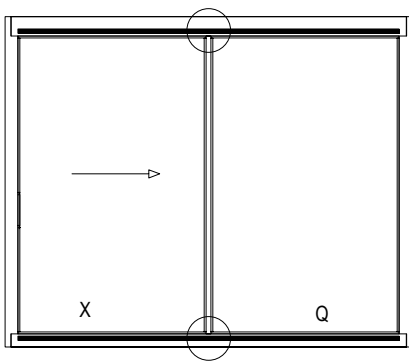

(X) DICHTINGSMIDDEL  
 MATIERE D'ETANCHEITE  
 SEALING AGENT  
 ABDICHTUNG

MONTAGEVOLGORDE  
 L'ORDRE DE MONTAGE  
 THE ORDER OF ASSEMBLY  
 MONTAGEREIHENFOLGE

REYNAGLUE  
 REYNAGLUE  
 REYNAGLUE  
 REYNAGLUE

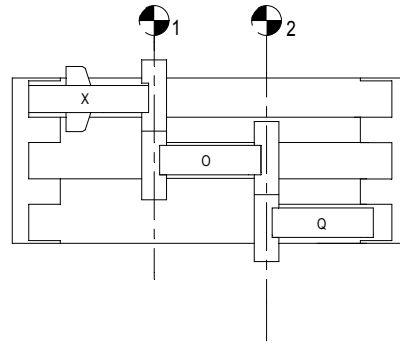
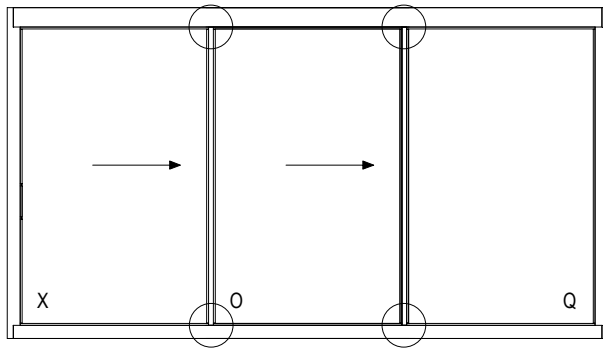

2

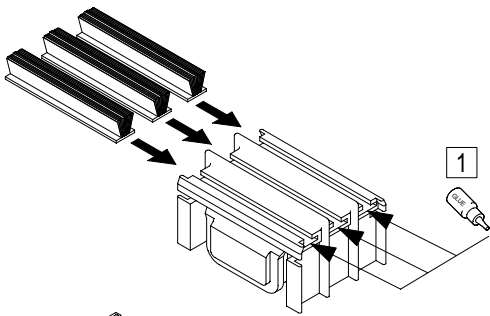

3

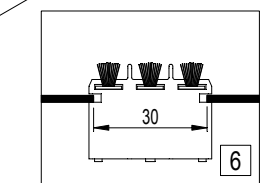
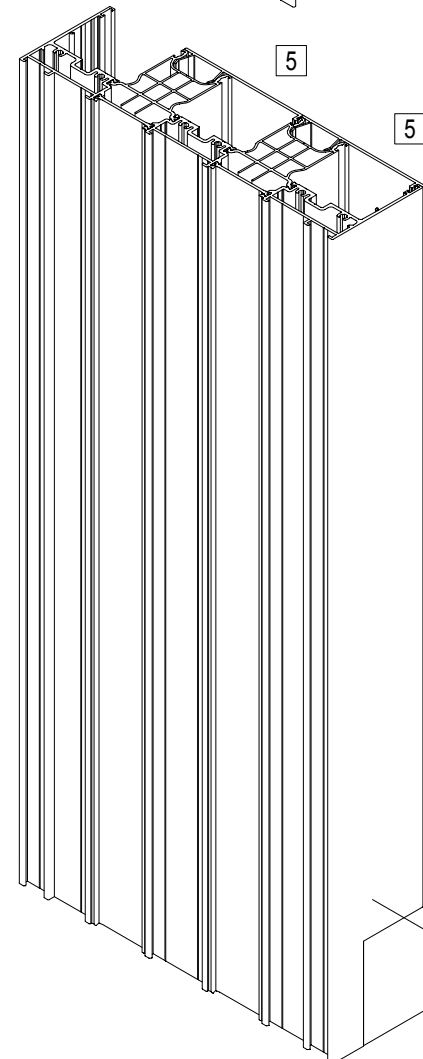
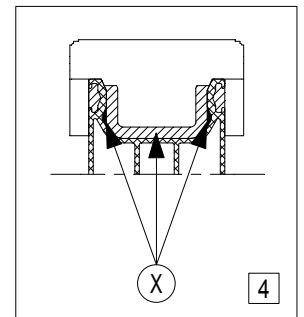
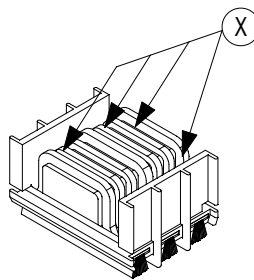

REYNAGLUE  
 REYNAGLUE  
 REYNAGLUE  
 REYNAGLUE

(X) DICHTINGSMIDDEL  
 MATIERE D'ETANCHEITE  
 SEALING AGENT  
 ABDICHTUNG

MONTAGEVOLGORDE  
 L'ORDRE DE MONTAGE  
 THE ORDER OF ASSEMBLY  
 MONTAGEREIHENFOLGE

1 2 3 .

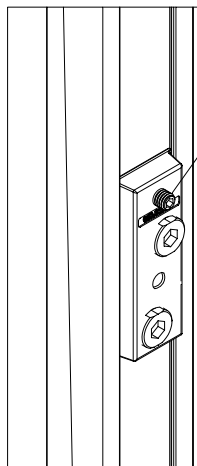

4 3  
 BLOK VASTESCHROEVEN OP VLEUGEL  
 VISSER A FOND LA CALE SUR L'OUVRANT  
 SCREW BLOCK ONTO VENT  
 KLOTZ AN FLUEGEL FESTSCHRAUBEN

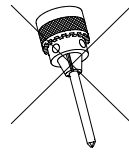

5  
 VEILIGHEIDSSCHROEF VOOR MONTAGE WISSELPROFIEL ( LOS BIJHOUDEN )  
 VIS DE SECURITE POUR LE MONTAGE DU PROFILE DE RECHANGE. (TENIR SEPRE)  
 SAFETY SCREW FOR MEETING SECTION ASSEMBLY. (KEEP LOOSE)  
 SICHERHEITSSCHRAUBE FÜR MONTAGE VON WECHSELPROFIL. (LOSE MITGEBEN)

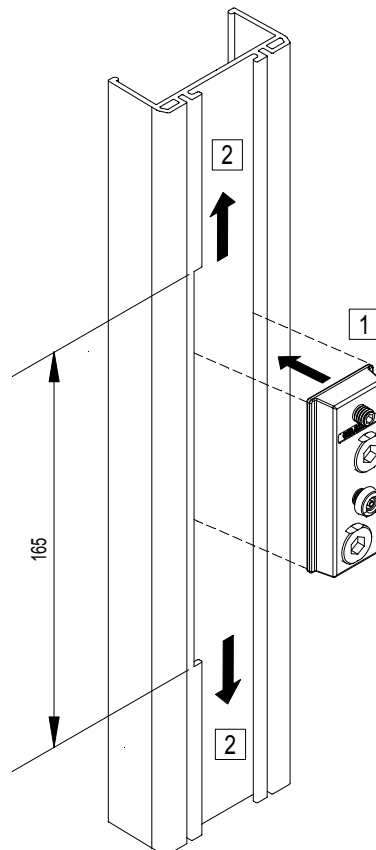

MONTAGEVOLGORDE L'ORDRE DE MONTAGE THE ORDER OF ASSEMBLY MONTAGEREIHENFOLGE	1	2	3	.
--	---	---	---	---

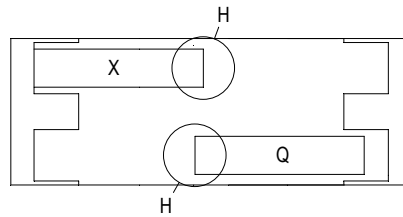
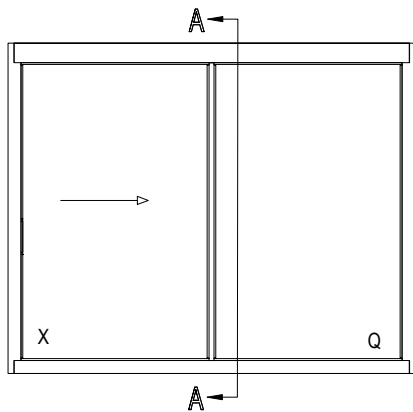

**3** REFERENTIEMAAT  
 DIMENSION DE REFERENCE  
 REFERENCE DIMENSION  
 REFERENZMASS

- 1** VERTICALE BRACKET INBRENGEN (DEELARTIKEL 062.8210 / 062.8226) (ENKEL VOOR SCHUIVENDE VLEUGEL)  
 INTRODUIRE LE SUPPORT VERTICAL (PARTIE DU REF. 062.8210/062.8226) (SEULEMENT POUR DES OUVRANTS COULISSANTS)  
 INSERT VERTICAL BRACKET (SUB-ARTICLE 062.8210/062.8226) (FOR SLIDING VENT ONLY)  
 VERTIKALEN VERBINDER EINSETZEN (TEILARTIKEL-NR. 062.8210/062.8226) (NUR FÜR SCHIEBEFLÜGEL)
- 2** AFSTELBLOKJES IN VLEUGEL SCHUIVEN (VOOR BEIDE VLEUGELS) (1/500mm x H)  
 FAIRE GLISSER LES CALES DE REGLAGE DANS L'OUVRANT. (POUR LES DEUX OUVRANTS) (1/500mm x H)  
 SLIDE ADJUSTING BLOCKS INTO VENT. (FOR BOTH VENTS) (1/500mm x H)  
 EINSTELLKLOETZE IN FLÜGEL SCHIEBEN. (FÜR BEIDE FLÜGEL) (1/500mm x H)

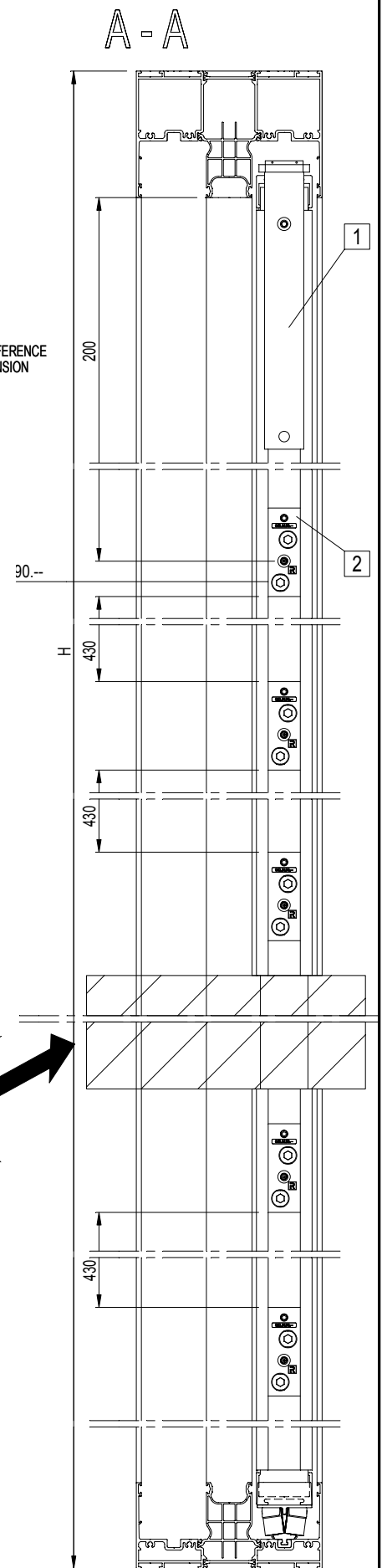

XQ / QX XX		2 x H
XQX		4 x H
QXXQ		5 x H
XOQ		4 x H

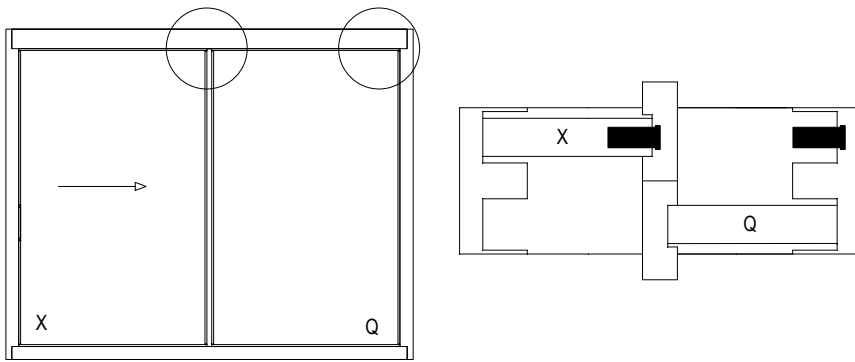

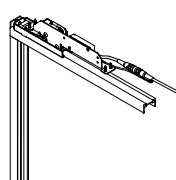
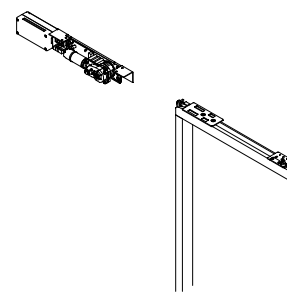
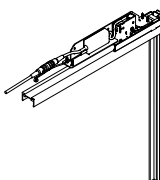
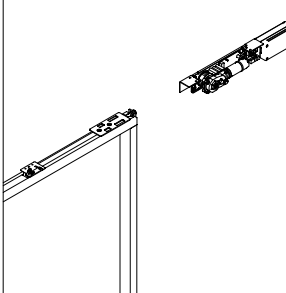
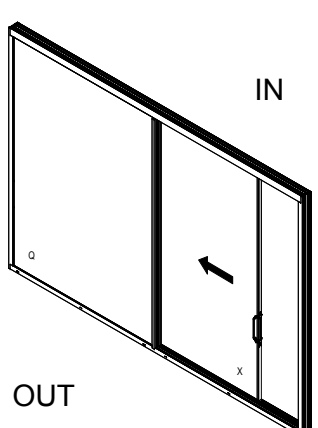
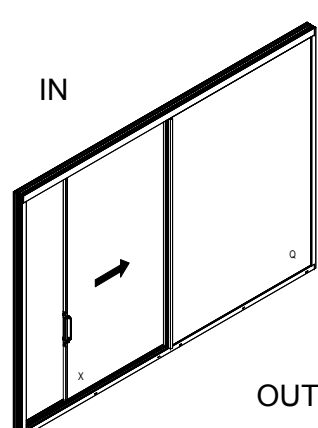
			
<p>062.8226.--</p>	<p>062.8201.-- 062.8210.--</p>	<p>062.8226.--</p>	<p>062.8200.-- 062.8210.--</p>
			
<p>DIN L</p>		<p>DIN R</p>	

For manuals on the electronic hardware for HFP147 Hi-Finity  
 (manual version or motorised version), please go to the article website.



- 1** **2** PVC PROFIEL EN DICHTINGEN OP WISSELPROFIEL MONTEREN  
 MONTER PROFILE PVC ET JOINTS SUR INTERMÉDIAIRE  
 FIT PVC PROFILE AND GASKETS ON MEETING SECTION  
 PVC PROFIL UND DICHTUNGEN AUF WECHSELPROFIL MONTIEREN

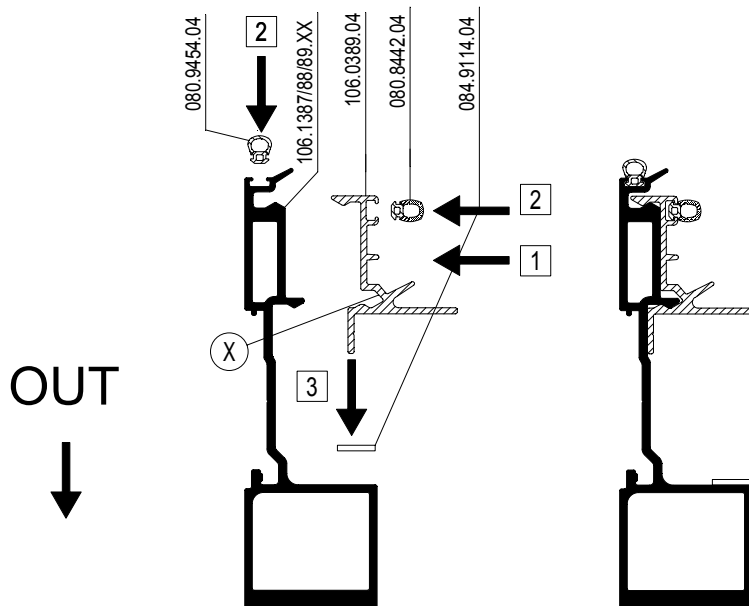
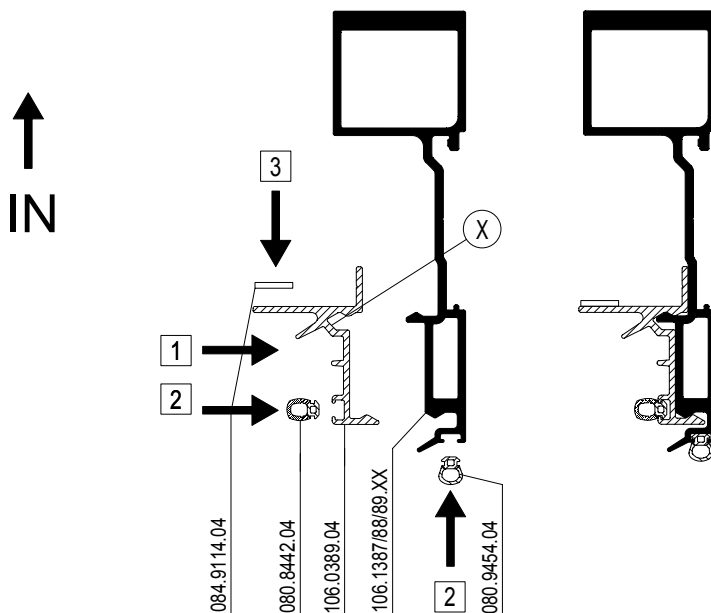

- 4** HERHAAL DIT VOOR ANDERE WISSELPROFIELEN  
 REPETER POUR LES AUTRES PROFILS INTERMÉDIAIRES  
 REPEAT FOR THE OTHER MEETING SECTIONS  
 AUF DER ANDERER WECHSELPROFILIEN WIEDERHOLEN

MONTAGEVOLGORDE L'ORDRE DE MONTAGE THE ORDER OF ASSEMBLY MONTAGEREIHENFOLGE	1	2	3	.
--	---	---	---	---

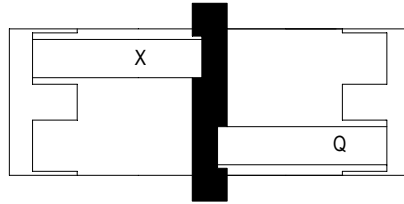
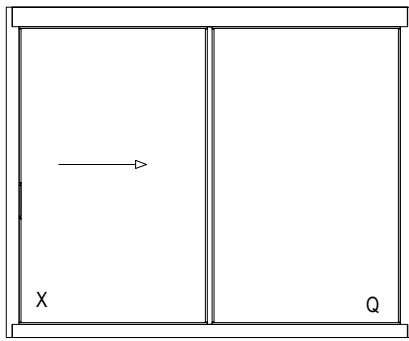

EERST VASTE CHICANE REGELEN TEN OPZICHTE VAN EPDM  
 NADIEN SCHUIVENDE CHICANE REGELEN TEN OPZICHTE VAN EPDM EN  
 VASTE CHICANE  
 AJUSTER D'ABORD LA CHICANE FIXE PAR RAPPORT A L'EPDM  
 AJUSTER ENSUITE LA CHICANE COULISSANT PAR RAPPORT A L'EPDM ET  
 LA CHICANE FIXE  
 FIRST ADJUST THE FIXED MEETING SECTION IN RELATION TO EPDM  
 AFTERWARDS ADJUST THE SLIDING MEETING SECTION IN RELATION TO  
 EPDM AND FIXED MEETING SECTION  
 ZUERST FESTEN WECHSELPROFIL EINSTELLEN BEZUEGLICH DER EPDM  
 NACHDEM SCHIEBENDEN WECHSELPROFIL EINSTELLEN BEZUEGLICH  
 DER EPDM UND DER FESTEN WECHSELPROFIL

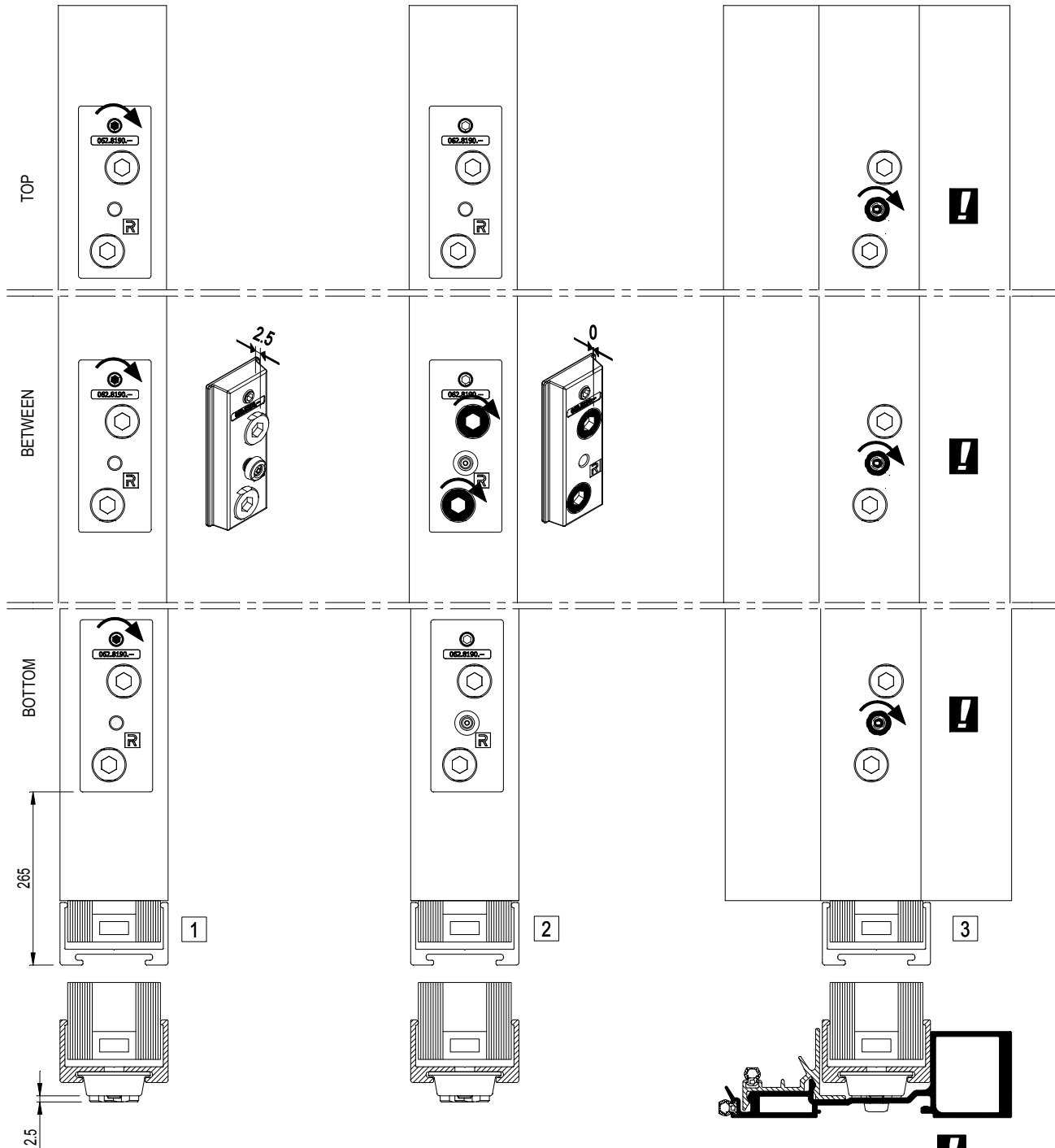

**1** BLOKKEN VASTSCHROEVEN OP ZIJN POSITIE M.B.V. STELSCHROEF  
 VISSER LES CALES EN POSITION A L'AIDE D'UNE VIS CALANTE.  
 SCREW BLOCKS INTO POSITION USING HEXAGON SOCKET.  
 KLOETZE MIT GEWINDESTIFT AN IHRER POSITION FESTSCHRAUBEN.

**2** AFSTELSCHROEVEN VASTDRAAIEN TOT AFSTAND 0  
 SERRER A FOND LA VIS REGLAGE JUSQU'A LA DISTANCE 0.  
 TIGHTEN ADJUSTING SCREWS TO DISTANCE 0.  
 STELSCHRAUBEN AUF ABSTAND 0 ANZIEHEN.

**3** WISSELPROFIEL HALFVAST MONTEREN M.B.V. 090.5615--  
 SERRER LE PROFIL INTERMEDIAIRE A MOITIE A L'AIDE DE 090.5615--  
 FIT MEETING SECTION LOOSELY USING 090.5615--  
 WECHSELPROFIL MIT 090.5615-- HALBFEST MONTEREN.

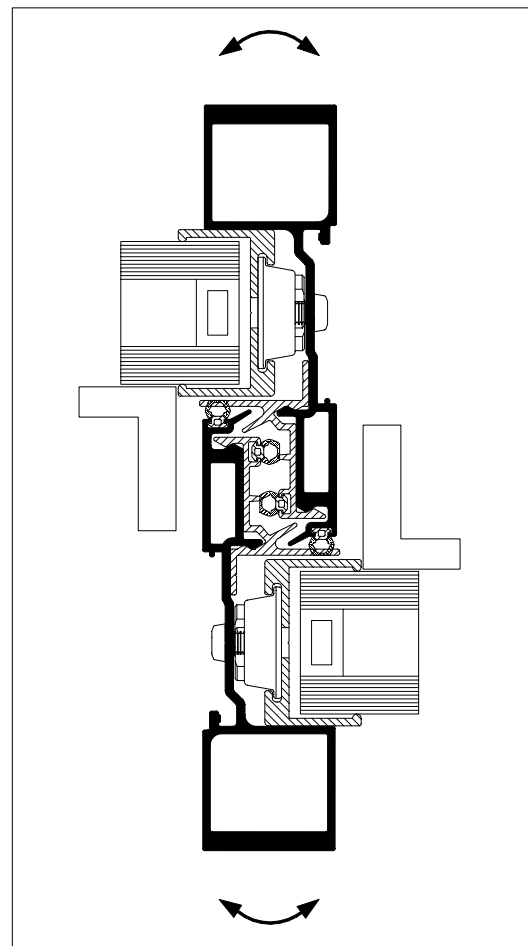
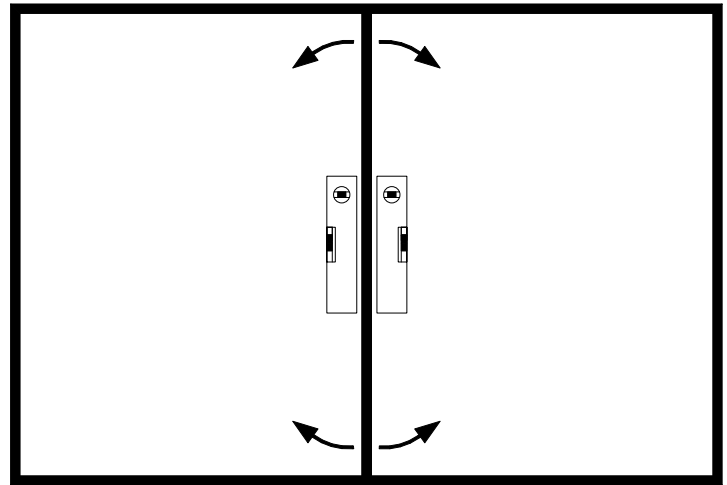
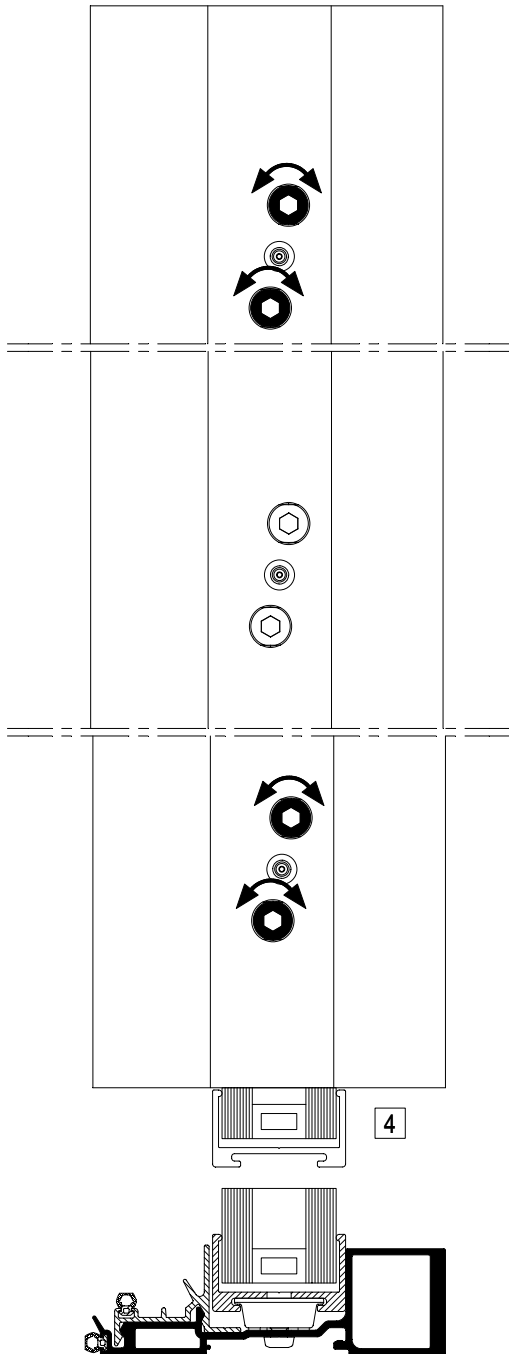

UITLIJNEN MET WATERPAS, LASER, WINKELHAAK, ...  
 ALIGNEMENT AU MOYEN DE NIVEAU, LASER, EQUERRE, ...  
 ALIGNMENT WITH LEVEL, LASER, CARPENTER'S SQUARE, ...  
 AUSRICHTUNG MIT NIVELLIERGERÄT, LASER, WINKELHAKEN, ...

- 4** WISSELPROFIEL VERTIKAAL EN HORIZONTAAL UITLIJNEN M.B.V. BOVENSTE EN ONDERSTE ASFTELSCHROEVEN  
 ALIGNER LE PROFIL INTERMEDIAIRE VERTICALEMENT ET HORIZONTALEMENT A L'AIDE DES VIS DE REGLAGE SUPERIEURES ET INFERIEURES  
 ALIGN MEETING SECTION VERTICALLY AND HORIZONTALLY USING TOP AND BOTTOM ADJUSTING SCREWS  
 WECHSELPROFIL MIT OBEREN UND UNTEREN STELLSCHRAUBEN VERTIKAL UND HORIZONTAL AUSRICHTEN

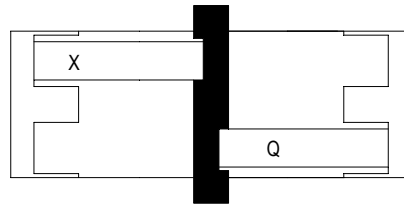
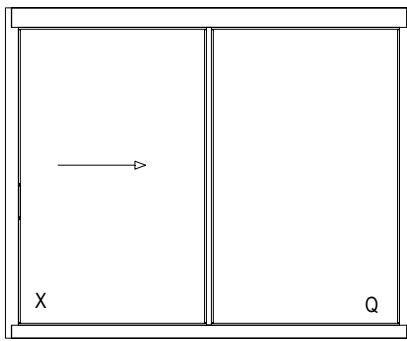

EERST VASTE CHICANE REGELEN TEN OPZICHTE VAN EPDM  
 NADIEN SCHUIVENDE CHICANE REGELEN TEN OPZICHTE VAN EPDM EN  
 VASTE CHICANE  
 AJUSTER D'ABORD LA CHICANE FIXE PAR RAPPORT A L'EPDM  
 AJUSTER ENSUITE LA CHICANE COULISSANT PAR RAPPORT A L'EPDM ET  
 LA CHICANE FIXE  
 FIRST ADJUST THE FIXED MEETING SECTION IN RELATION TO EPDM  
 AFTERWARDS ADJUST THE SLIDING MEETING SECTION IN RELATION TO  
 EPDM AND FIXED MEETING SECTION  
 ZUERST FESTEN WECHSELPROFIL EINSTELLEN BEZUEGLICH DER EPDM  
 NACHDEM SCHIEBENDEN WECHSELPROFIL EINSTELLEN BEZUEGLICH  
 DER EPDM UND DER FESTEN WECHSELPROFIL

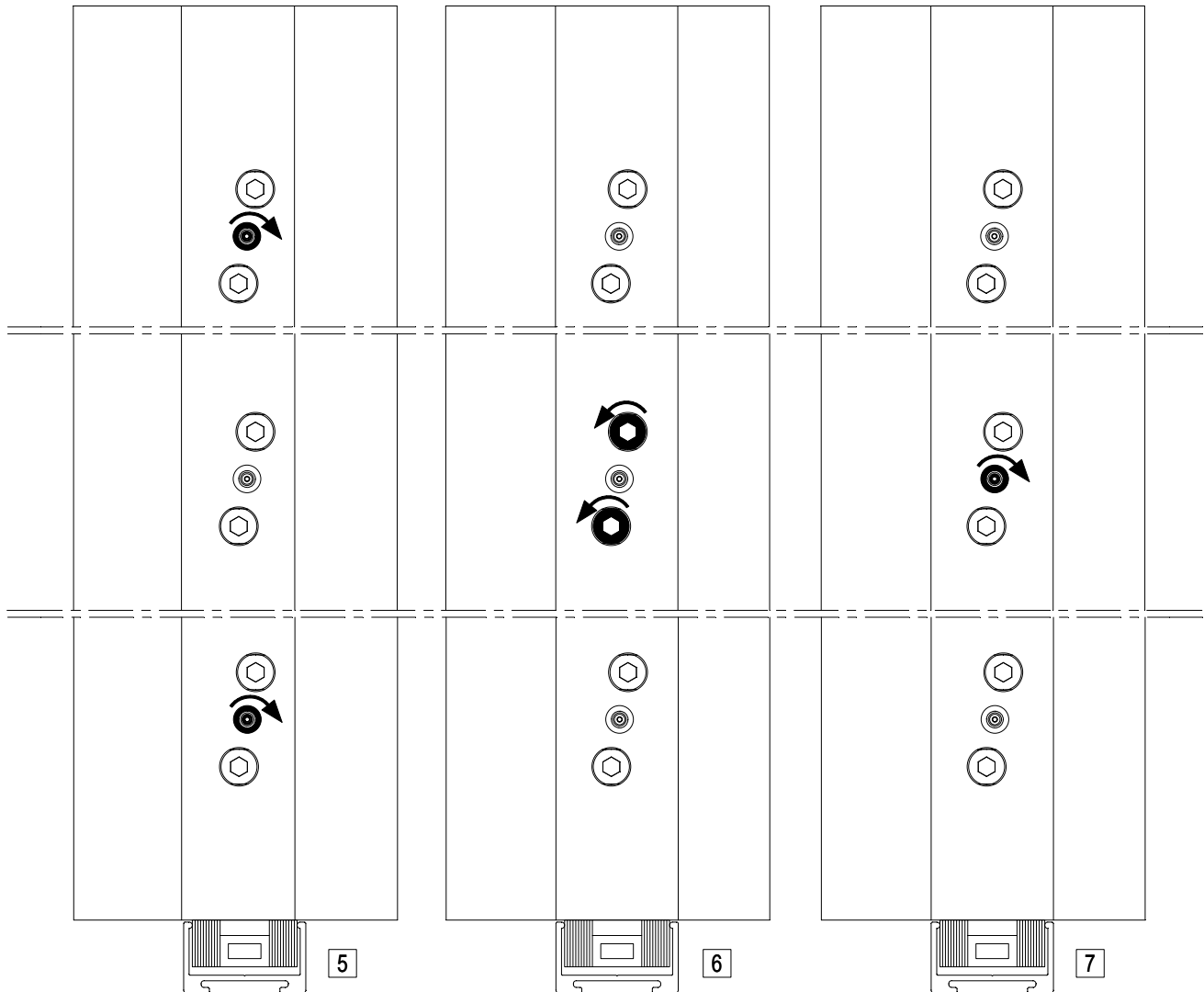

**5** VEILIGHEIDSSCHROEVEN VASTDRAAIEN MET 090.5615.-  
 SERRER A FOND LES VIS DE SECURITE AVEC 090.5615.-  
 TIGHTEN SAFETY SCREWS WITH 090.5615.-  
 SICHERHEITSSCHRAUBEN MIT 090.5615.- ANZIEHEN

**6** REST VAN AFSTELSCHEEVEN LOSDRAAIEN TOT TEGENDRUK  
 DESSERRER LE RESTE DES VIS DE REGLAGE JUSQU'A LA CONTRE-PRESSION  
 LOOSEN REMAINING ADJUSTING SCREWS UNTIL COUNTERPRESSURE  
 RESTLICHE STELLSCHRAUBEN AUF GEGENDRUCK LOSDREHEN

**7** DE REST VAN VEILIGHEIDSSCHROEVEN VASTDRAAIEN  
 SERRER A FOND LE RESTE DES VIS DE SECURITE  
 TIGHTEN THE REMAINING SAFETY SCREWS  
 RESTLICHE SICHERHEITSSCHRAUBEN ANZIEHEN

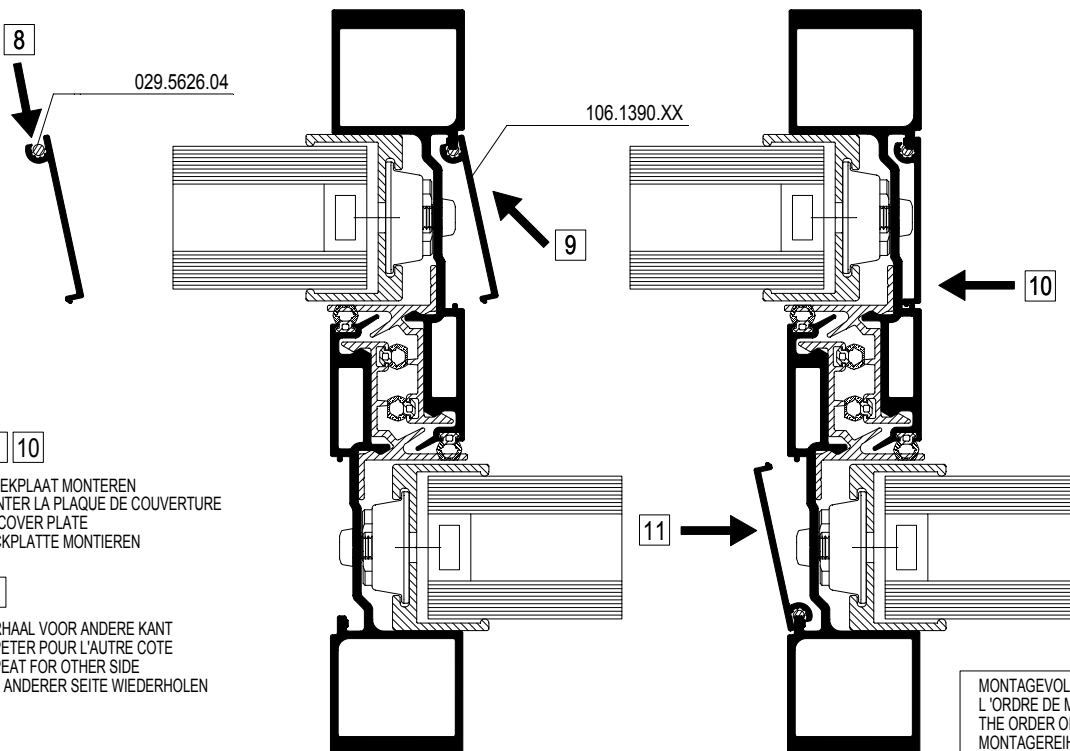
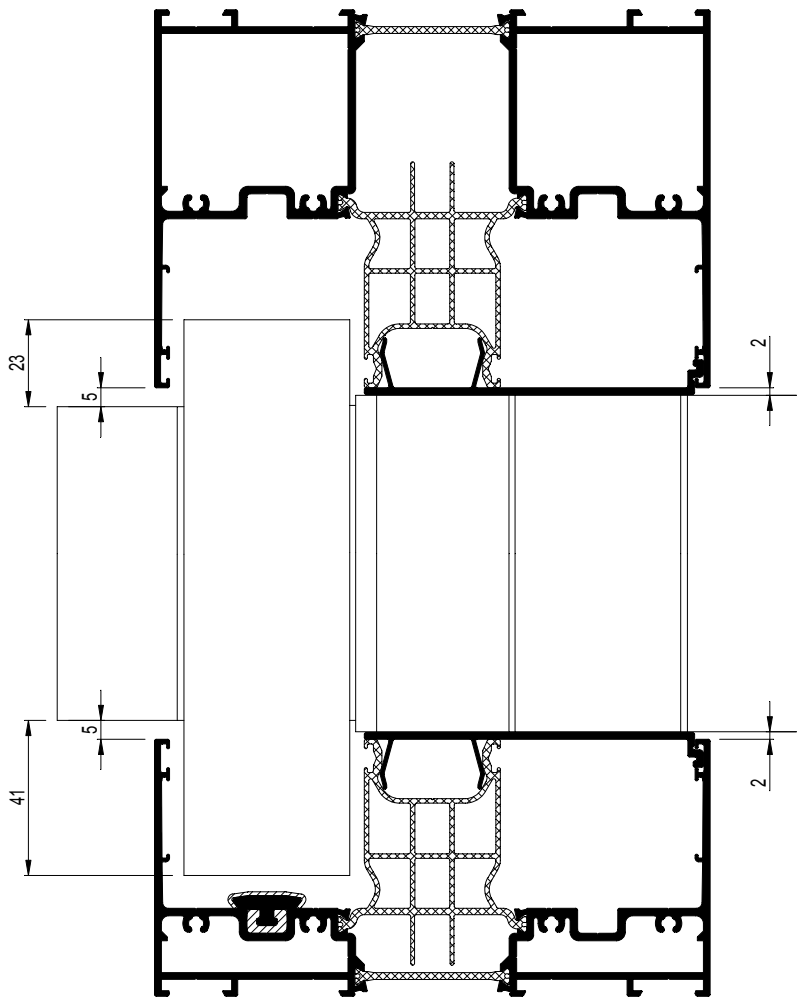

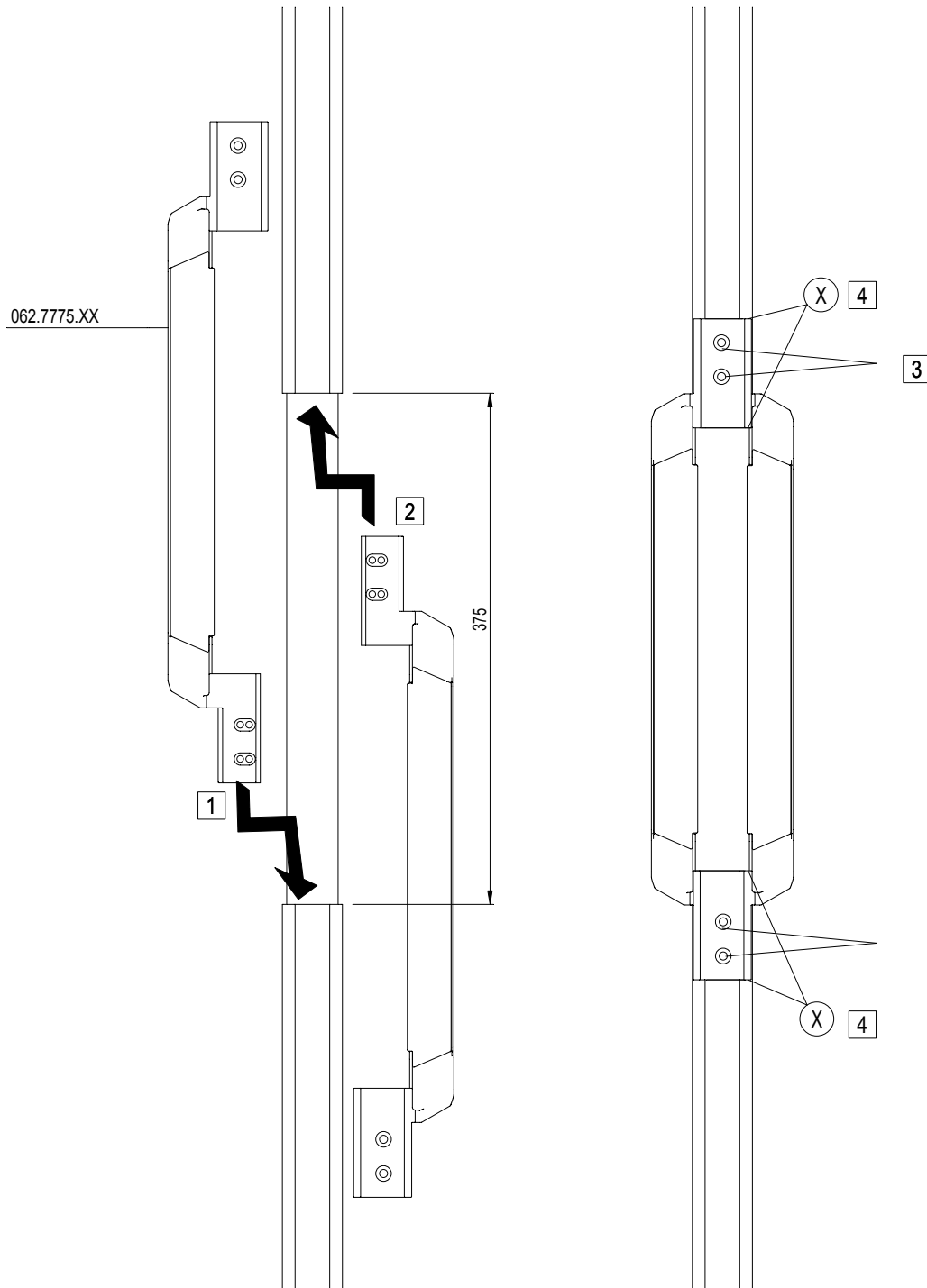
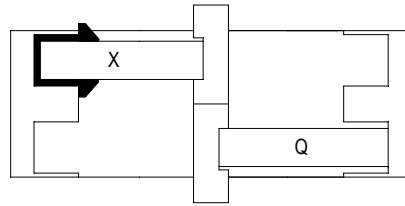
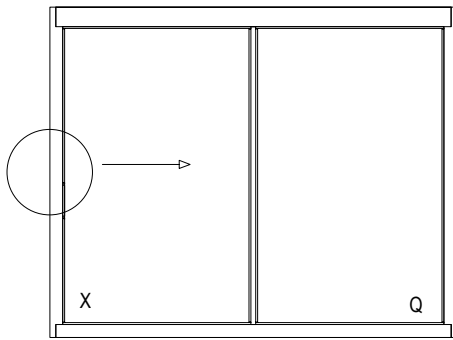

- 5 AFWERKINGPROFIEL PLAATSEN MET LIJM EN GLASSTEUN  
 POSER LE PROFIL DE FINITION AVEC DE LA COLLE ET LE SUPPORT DE VITRAGE  
 FIT FINISHING PROFILE WITH GLUE AND GLASS SUPPORT  
 AUSFUEHRUNGSPROFIL MIT KLEBER UND GLASAUFLAGEPROFIL ANBRINGEN

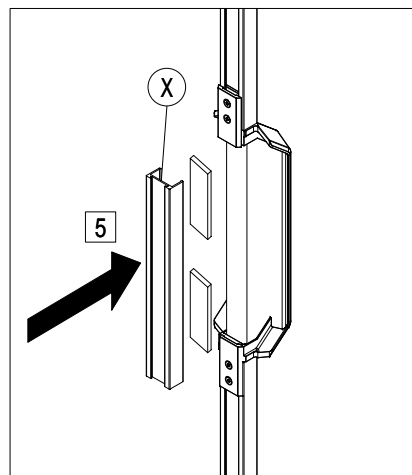
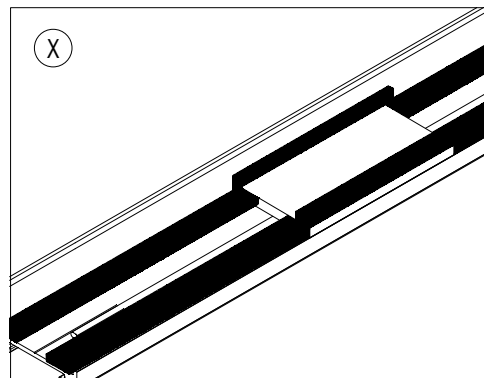
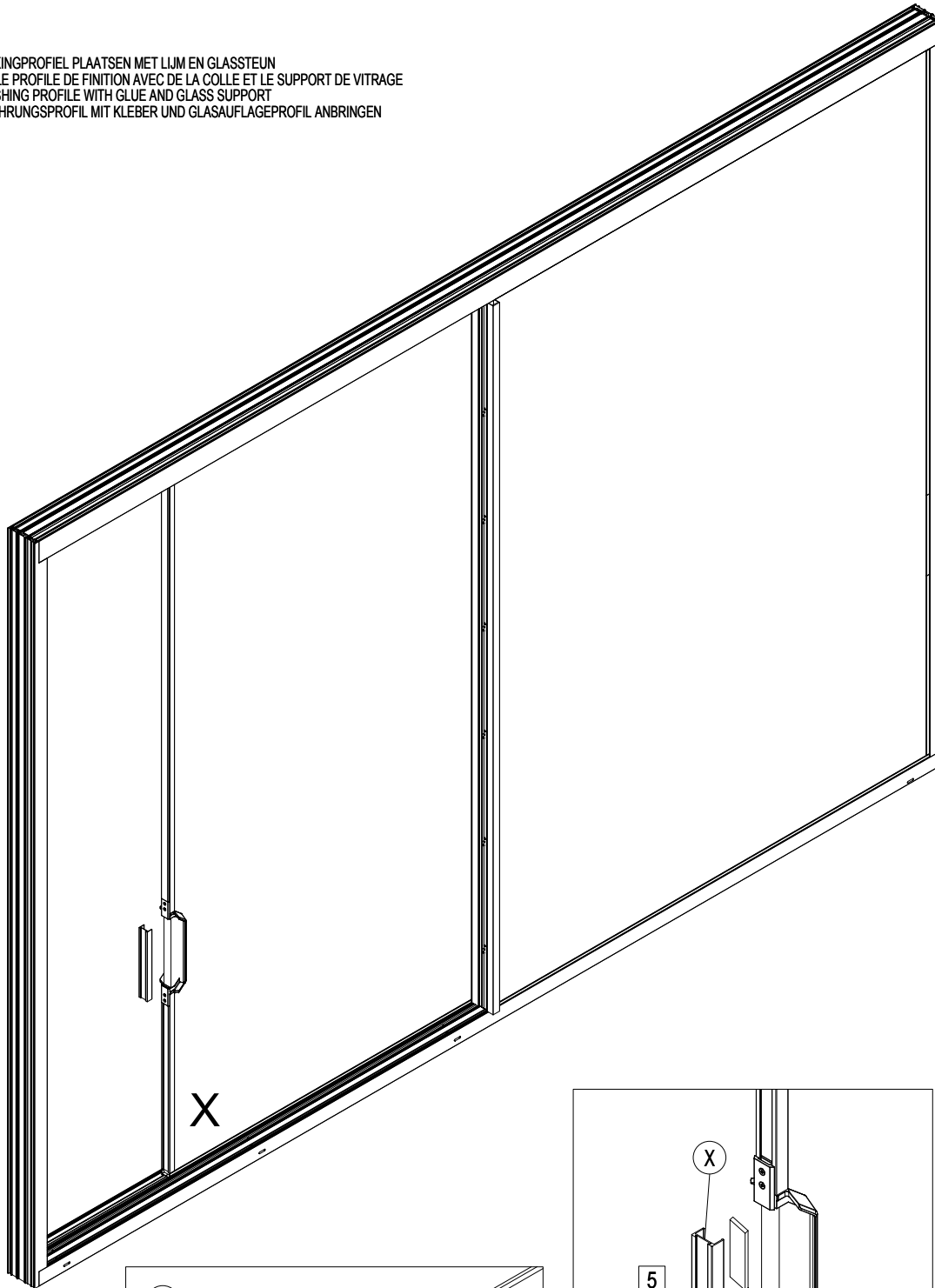

MONTAGEVOLGORDE	1	2	3	.
L'ORDRE DE MONTAGE				
THE ORDER OF ASSEMBLY				
MONTAGEREIHENFOLGE				

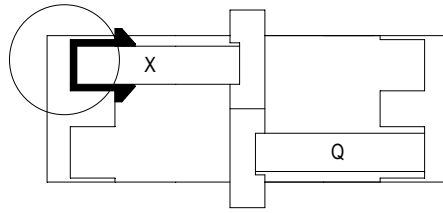
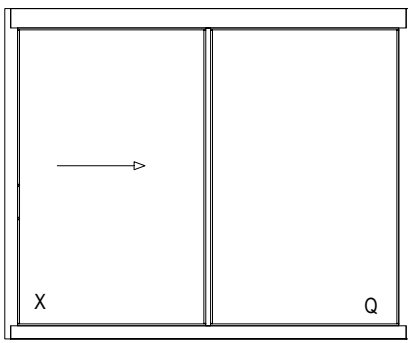

- 1 AFWERKINGSRUBBER INBRENGEN  
INSERER LE CAOUTCHOUC DE FINITION  
INSERT RUBBER SEALING STRIP  
AUSFÜHRUNGSGUMMI EINSETZEN

080.9150.04

1

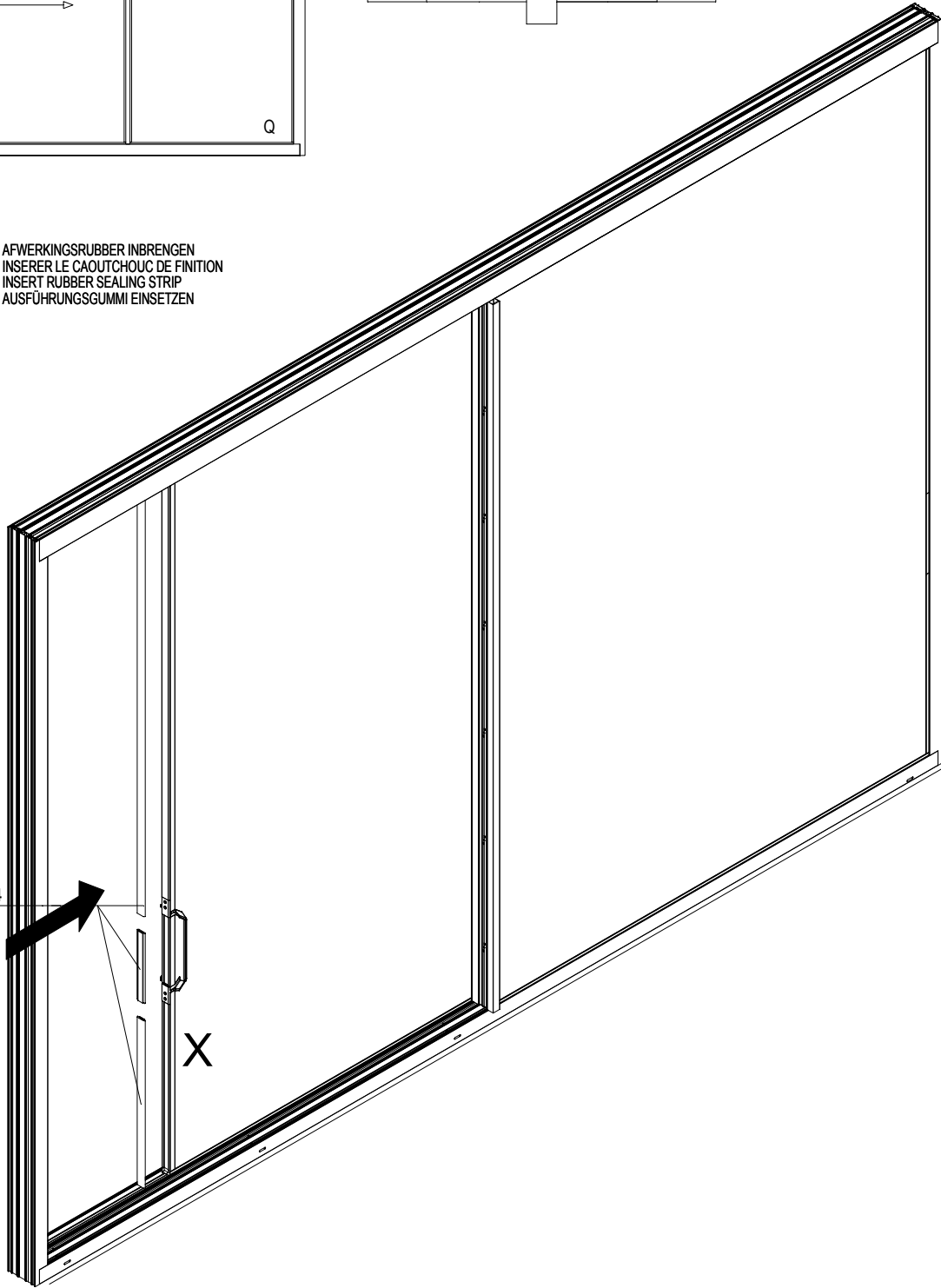



XQ / XX / QXXQ (2 - RAIL)  
 XXQ (3 - RAIL)

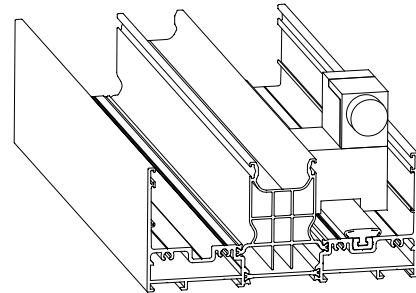
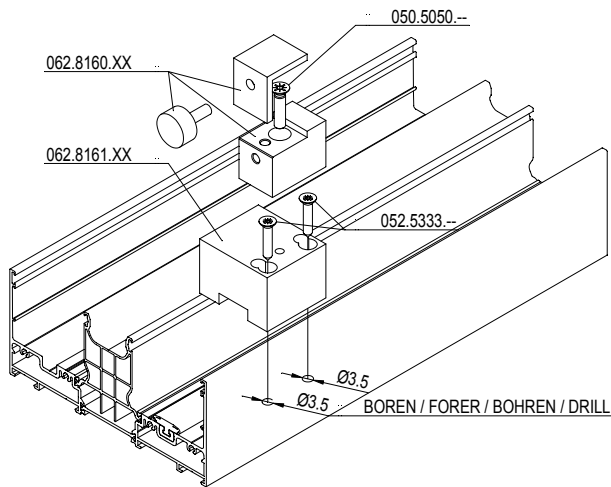

XQX (2 - RAIL)  
 XXQ (3 - RAIL)

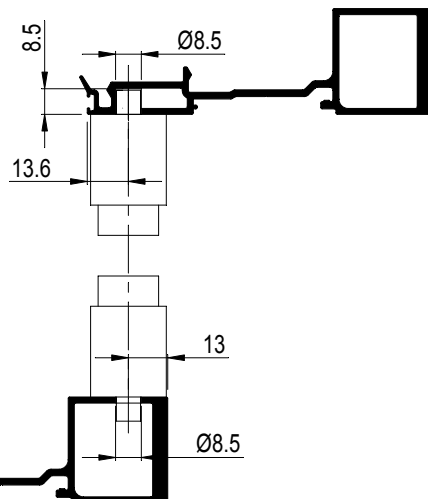
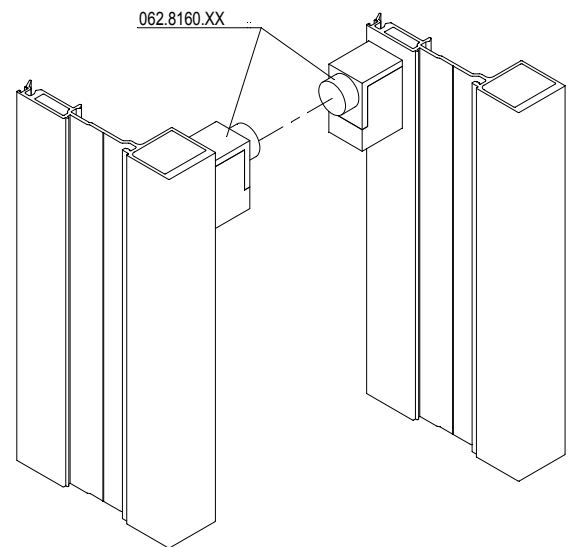
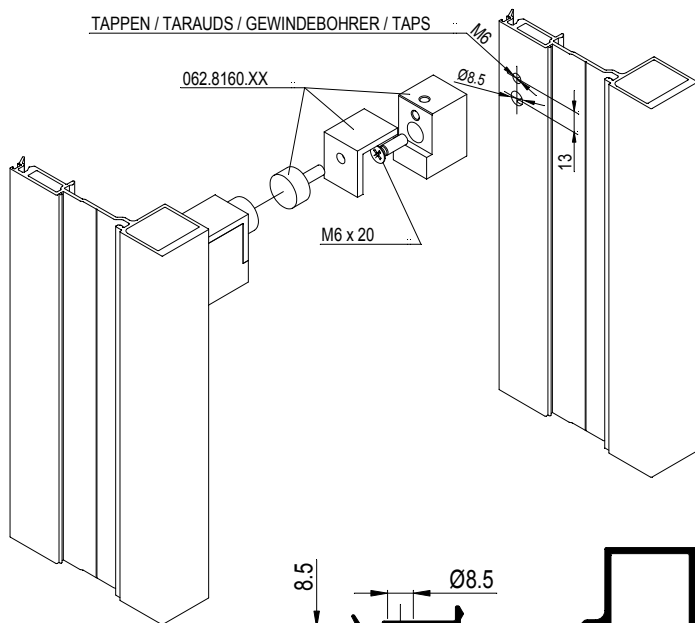

MONTAGEVOLGORDE				
L'ORDRE DE MONTAGE				
THE ORDER OF ASSEMBLY	1	2	3	.
MONTAGEREIHENFOLGE				

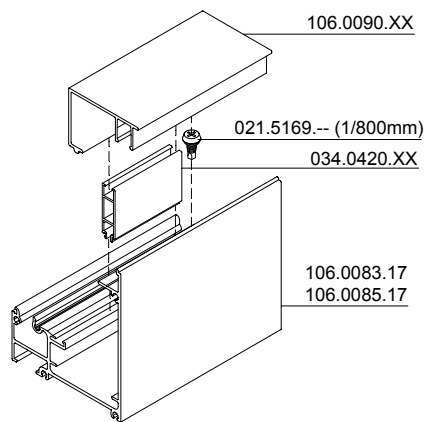
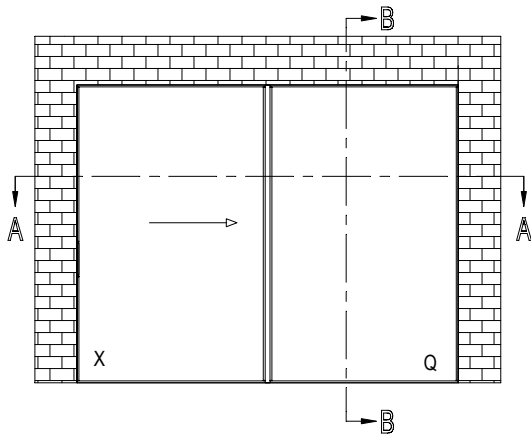

### A-A

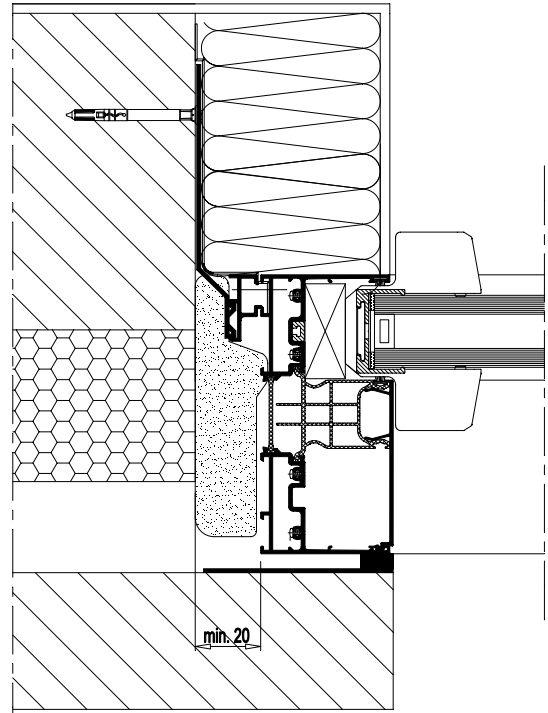

### B-B

106.1383.XX

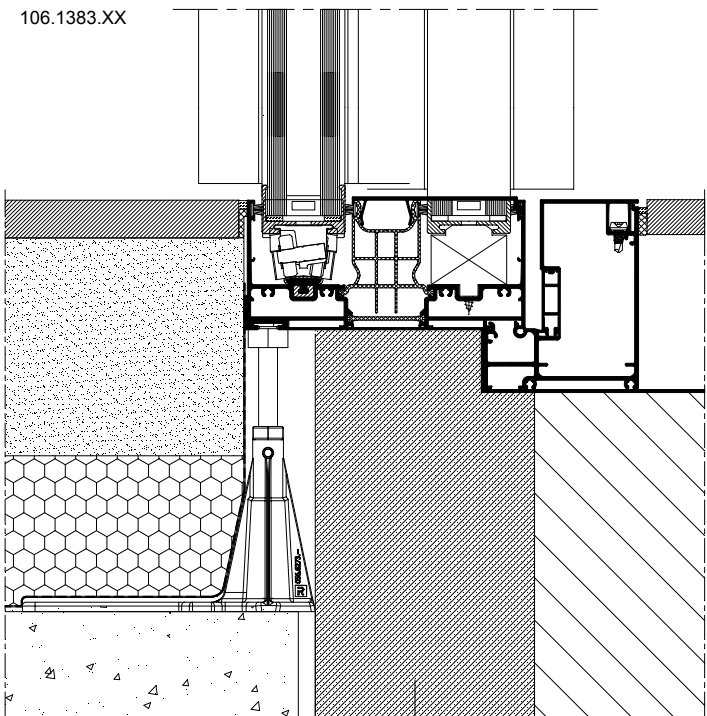

			#	$L_m$	
106.0083.17			1	B - 140	25D.C. ...
106.0090.XX			1	B - 140	25D.C. ...
034.0420.XX			1/500mm	50	25D.C. ...

		#	
080.9381.04		B	25D.G. ...
062.9290.17		2	25D.G. ...
052.5300.--		8	25D.G. ...
021.5169.--		1/800mm	25D.G. ...



**!** DRUKVASTE ISOLERENDE STEENLAAG  
ASSISE ISOLANTE ET RÉSISTANTE À LA COMPRESSION  
COMPRESSION-RESISTANT INSULATING LAYER OF STONES  
DRUCKFESTE ISOLIERENDE BACKSTEINSCHICHT

A-A

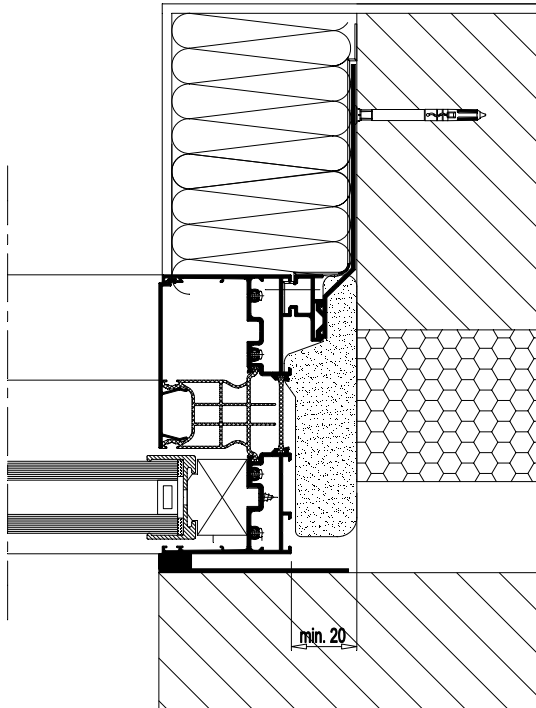

B-B

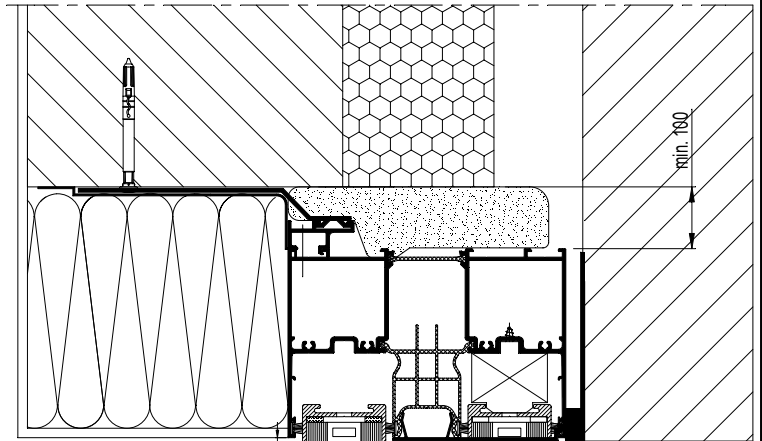

B-B

106.1385.XX

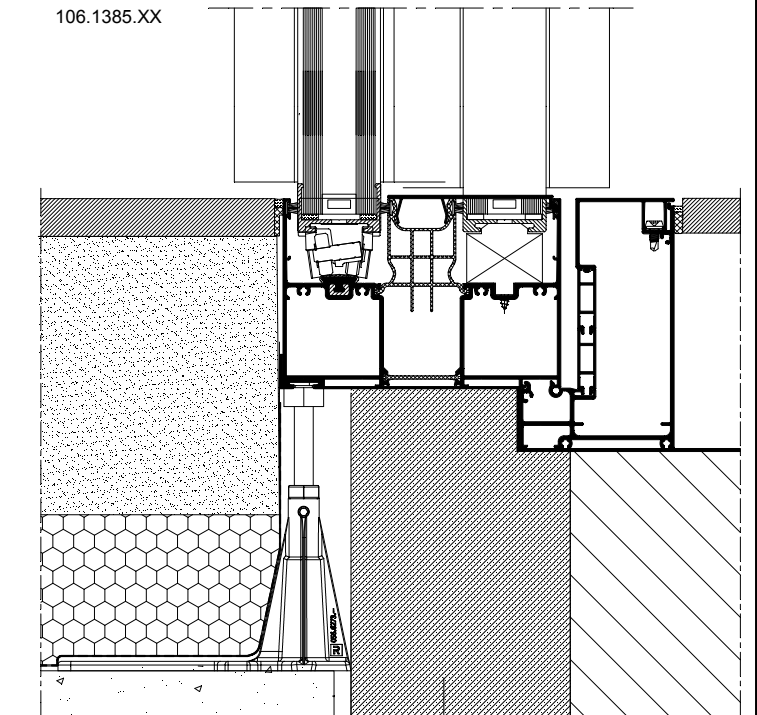

			#	$\leftarrow L_m$	
106.0085.17			1	B - 140	25D.C. ...
106.0090.XX			1	B - 140	25D.C. ...
034.0420.XX			2/500mm	50	25D.C. ...

		#	
080.9381.04		B	25D.G. ...
062.9291.17		2	25D.G. ...
052.5300.--		8	25D.G. ...
25D.G. ...		1/800mm	25D.G. ...



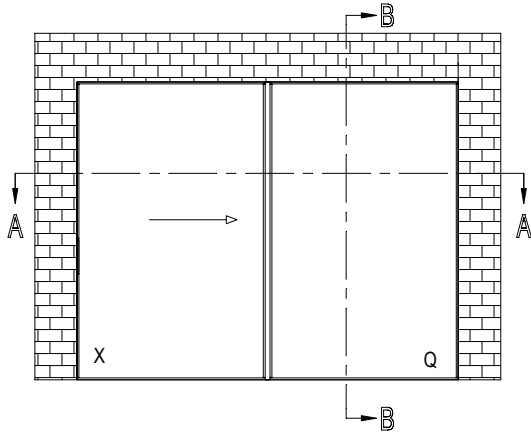

B - B

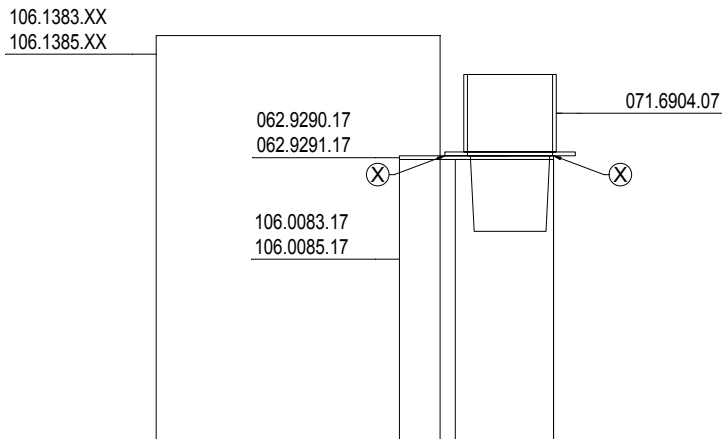
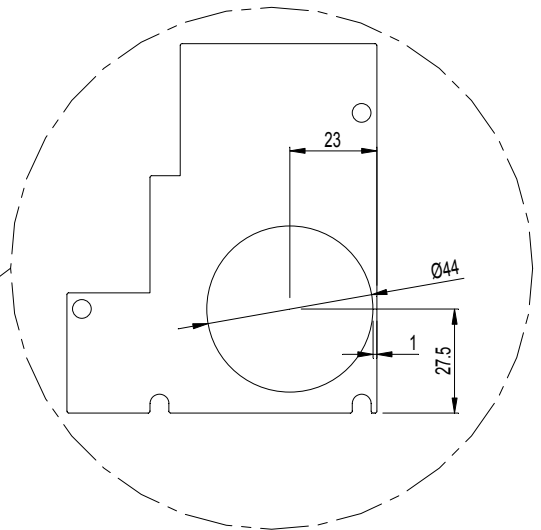
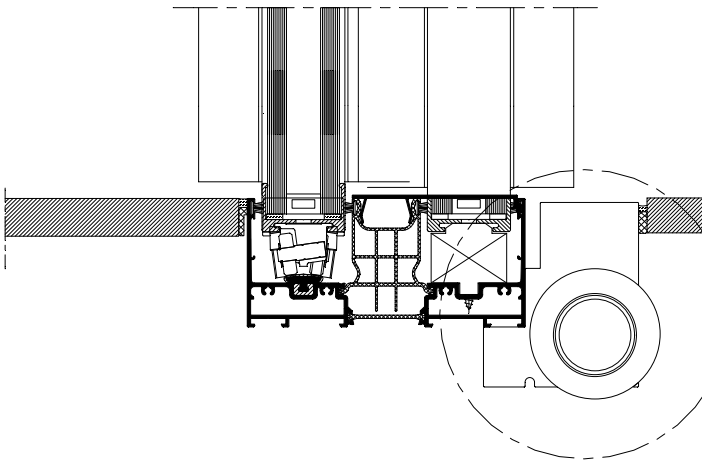

(X)	DICHTINGSMIDDEL MATIERE D'ETANCHEITE SEALING AGENT ABDICHTUNG
-----	--

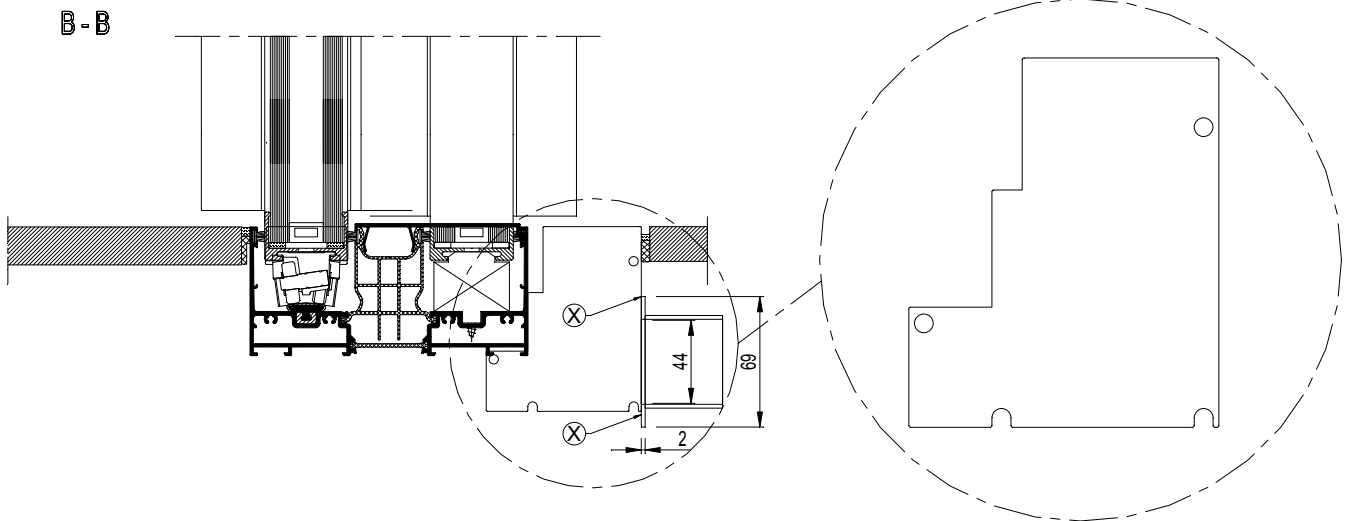

106.1383.XX  
106.1385.XX

062.9290.17  
062.9291.17

106.0083.17  
106.0085.17

071.6904.07

(X) DICHTINGSMIDDEL  
Matiere d'Etancheite  
SEALING AGENT  
ABDICHTUNG

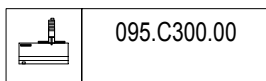
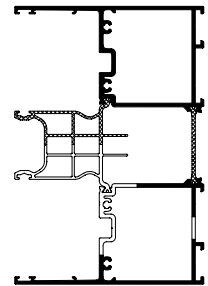
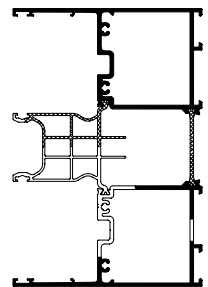
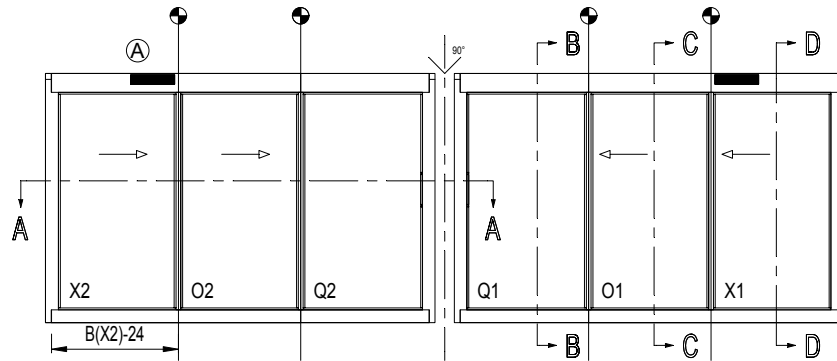
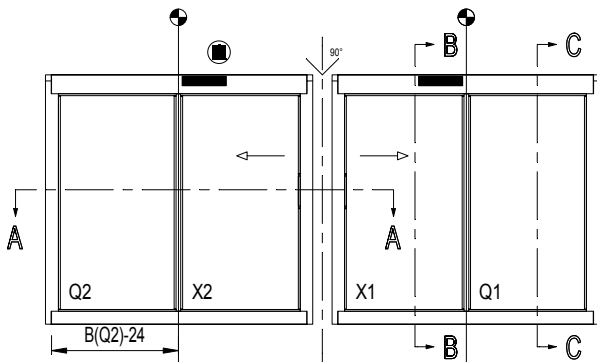
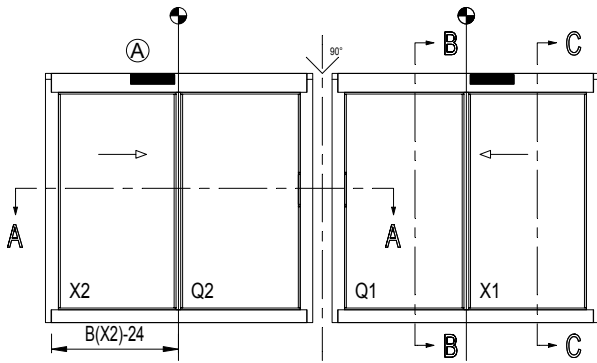

of / ou / or / oder

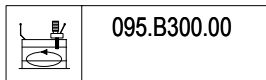

of / ou / or / oder

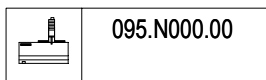

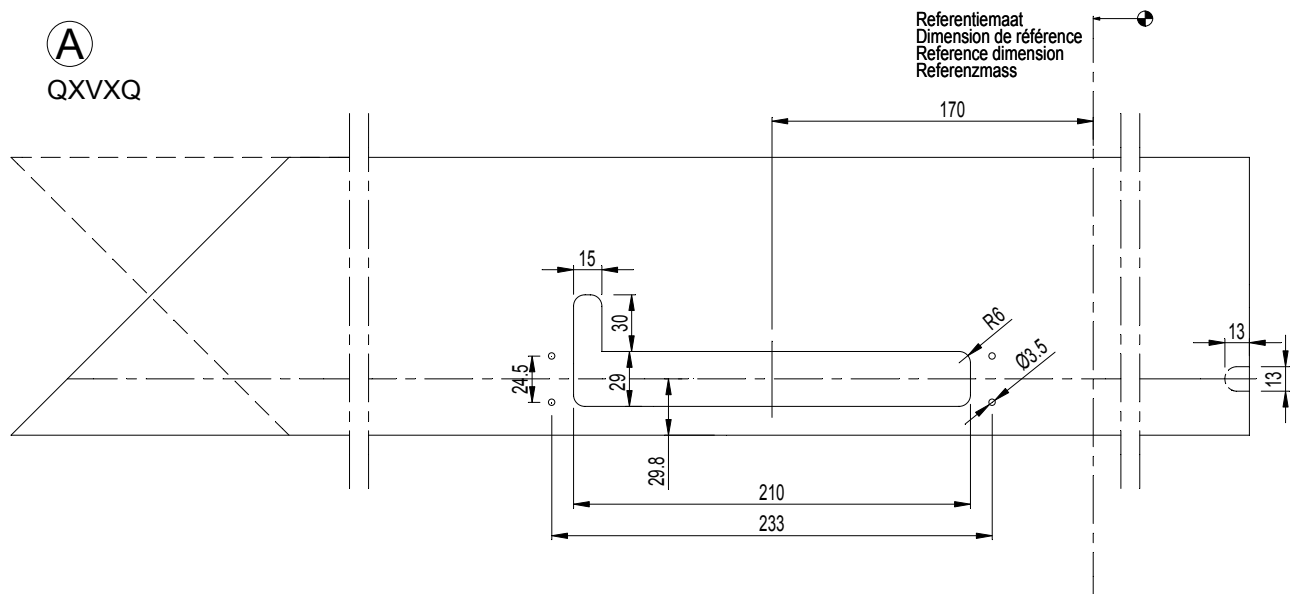
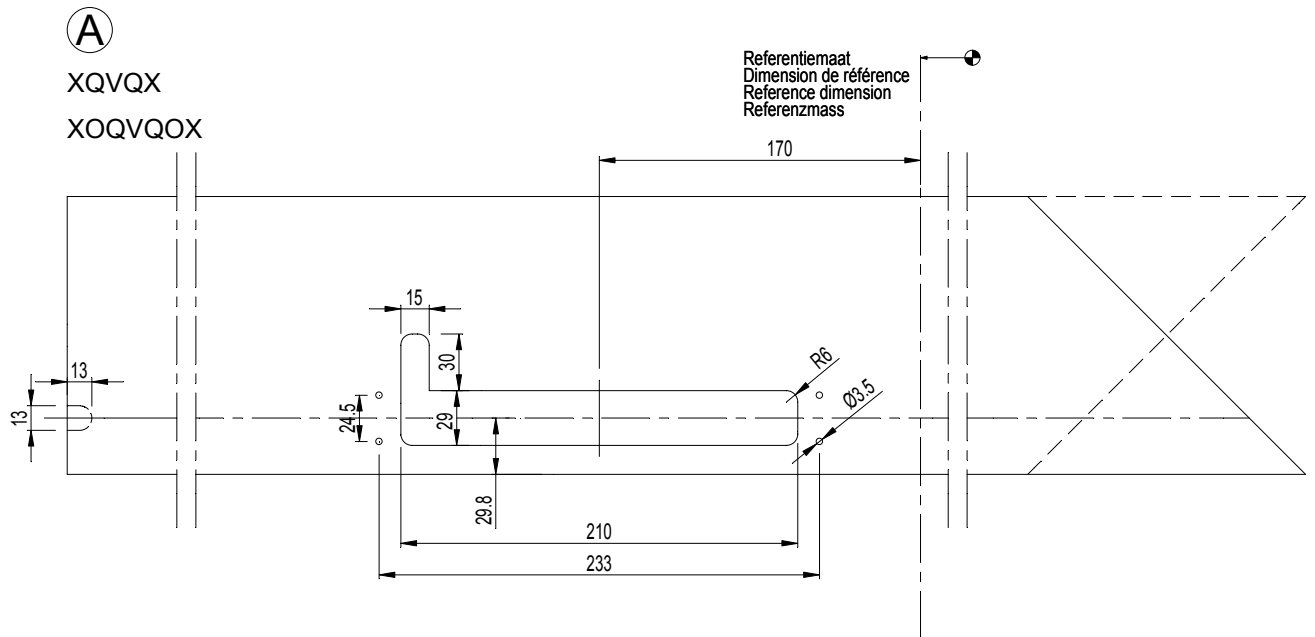

--- Inside  
 ——— Outside

POSITION OF THE REFERENCE  
 MEASURED FROM THE STRAIGHT CUT  
 ON THE HORIZONTAL FRAME PROFILE

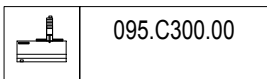
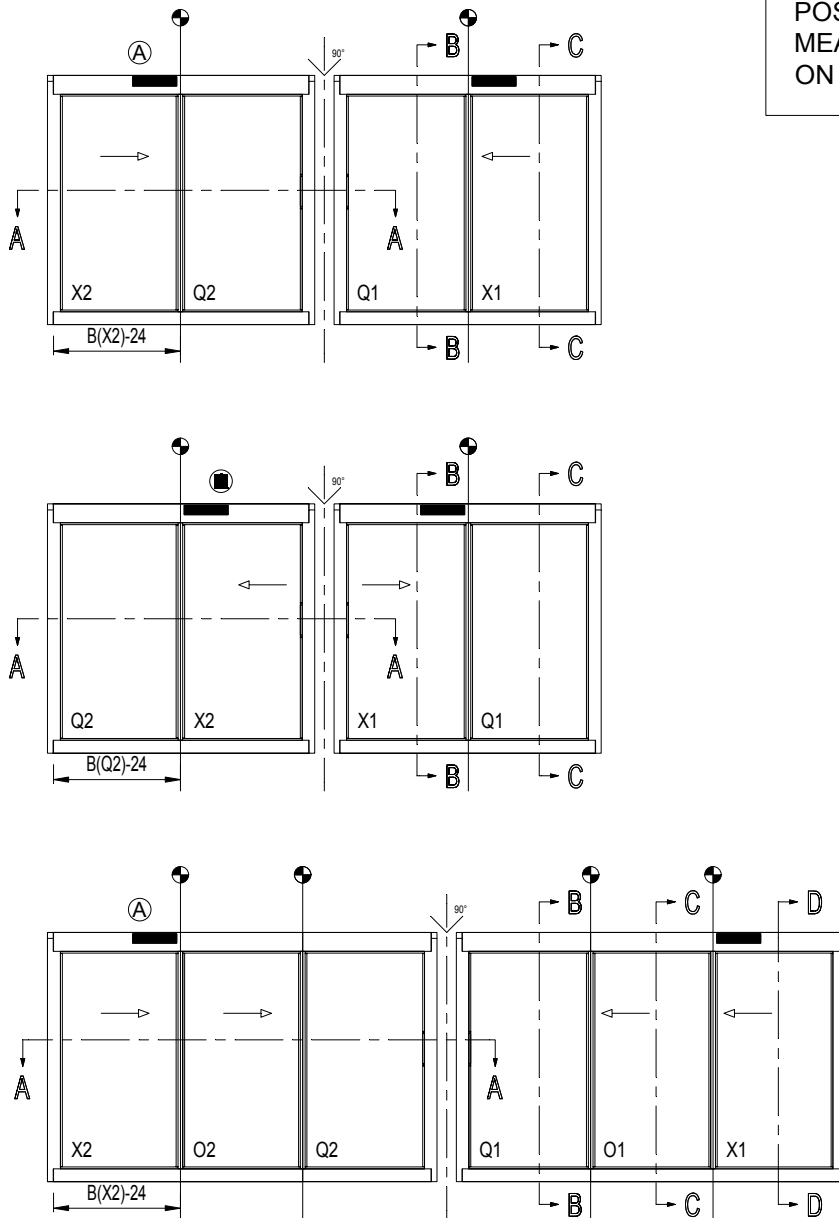

of / ou / or / oder

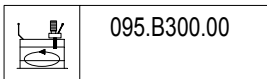

of / ou / or / oder

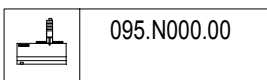

**!** STEP GLAS  
 ETAPE DE VERRE  
 STEP GLASS  
 STEP GLASS

ZIE 25D.E....  
 VOIRE 25D.E....  
 SEE 25D.E....  
 SIEHE 25D.E....



**A B C D**

MILLING PATTERNS

## Outside Corner

XQVQX

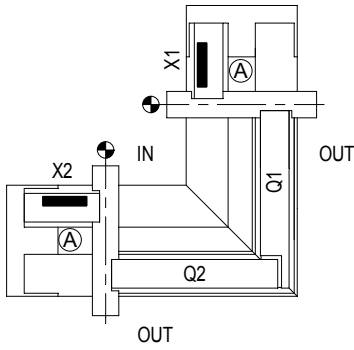

## Inside Corner

XQVQX

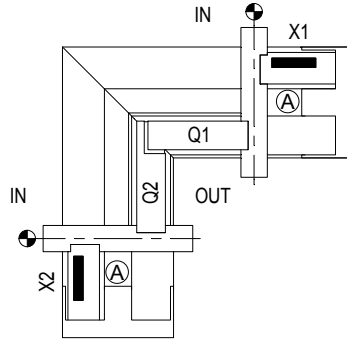

## Outside Corner

QXVXQ

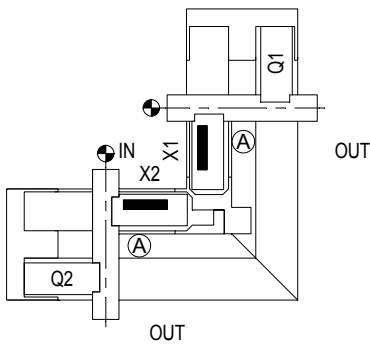

## Inside Corner

QXVXQ

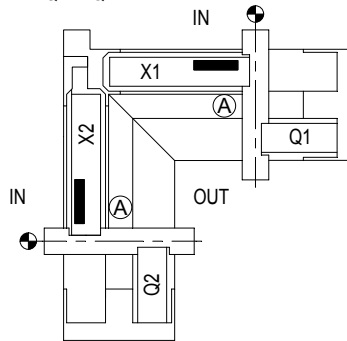

## Outside Corner

XOQVQOX

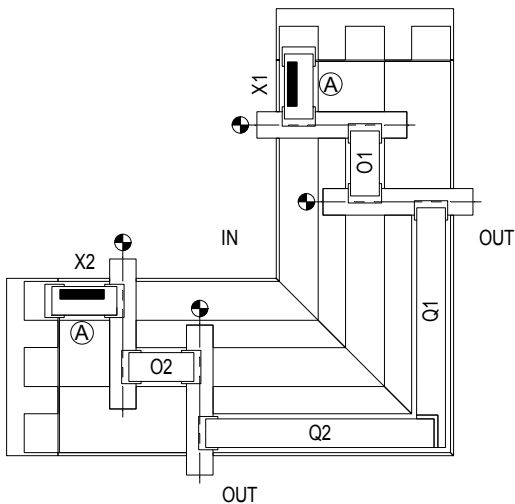

## Inside Corner

XOQVQOX

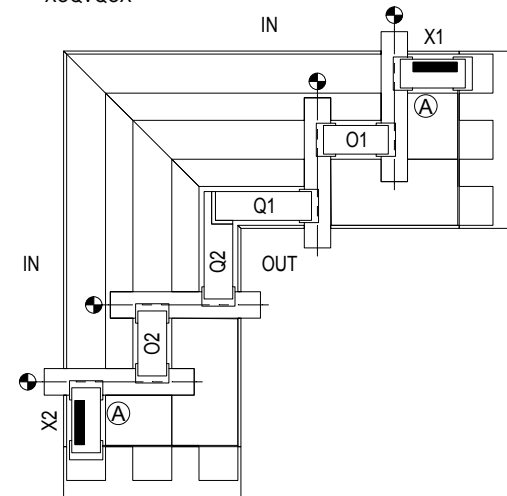

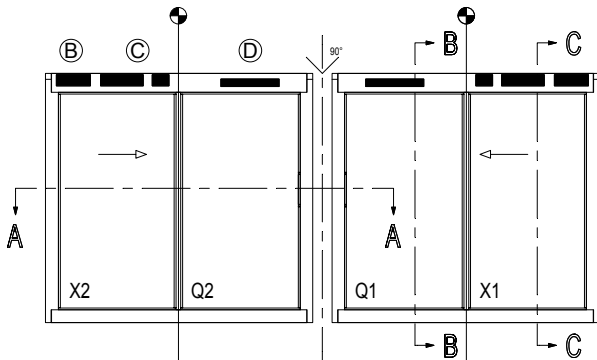

$B(X)+B(Q) = \text{min. } 2000$   
 $b(Q) \geq b(X)$

Outside	Inside
$B(Q) \geq B(X) - 50$	$B(Q) \geq B(X) + 39$

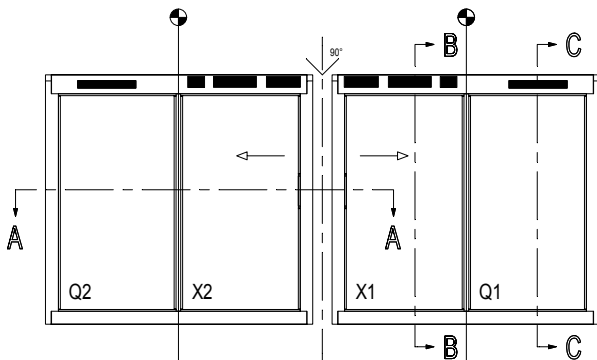

$B(X)+B(Q) = \text{min. } 2000$   
 $b(Q) \geq b(X)$

Outside	Inside
$B(Q) \geq B(X) - 94$	$B(Q) \geq B(X) - 7$

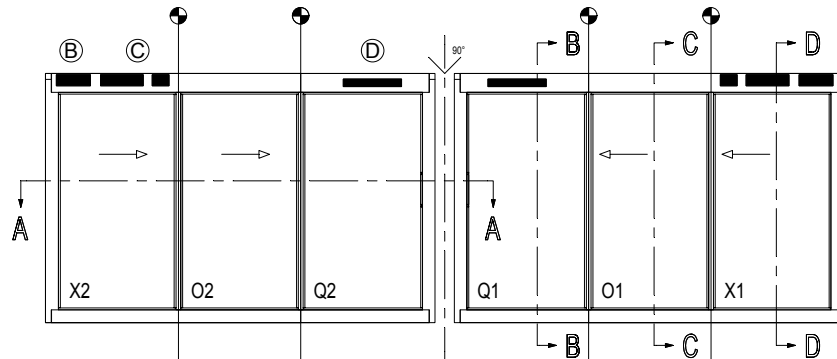

$B(X)+B(O)+B(Q) = \text{min. } 3000$   
 $b(Q) \geq b(O) \geq b(X)$

Outside	Inside
$B(Q) \geq B(O) + 2$	$B(Q) \geq B(O) + 178.5$
$B(Q) \geq B(X) - 50$	$B(Q) \geq B(X) + 126$

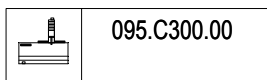

of / ou / or / oder

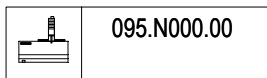

+

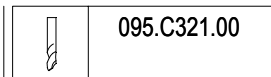

MONTAGEVOLGORDE  
 L'ORDRE DE MONTAGE  
 THE ORDER OF ASSEMBLY  
 MONTAGEREIHENFOLGE

1 2 3 .

STEP GLAS  
 ETAPE DE VERRE  
 STEP GLASS  
 STEP GLASS

ZIE 25D.E....  
 VOIRE 25D.E....  
 SEE 25D.E....  
 SIEHE 25D.E....

**A B C D** MILLING PATTERNS

### Outside Corner

XQVQX

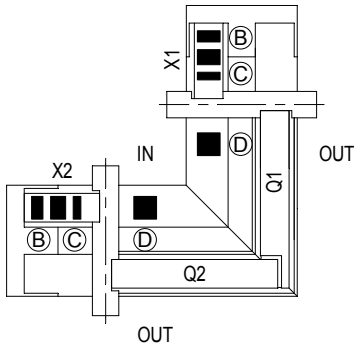

### Inside Corner

XQVQX

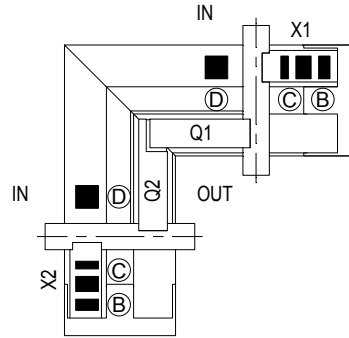

### Outside Corner

QXVXQ

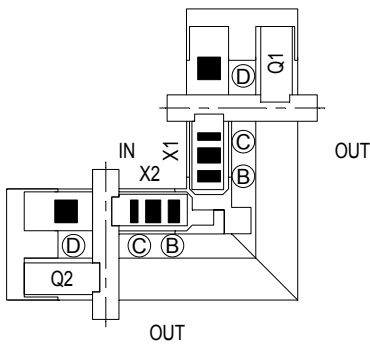

### Inside Corner

QXVXQ

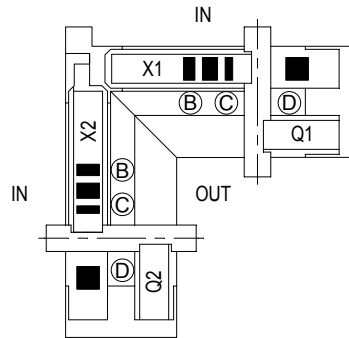

### Outside Corner

XOQVQOX

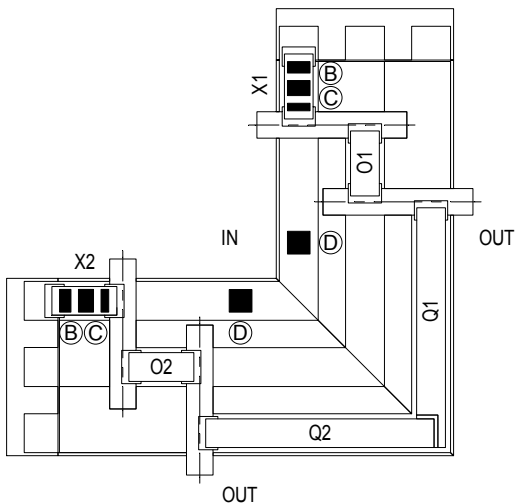

### Inside Corner

XOQVQOX

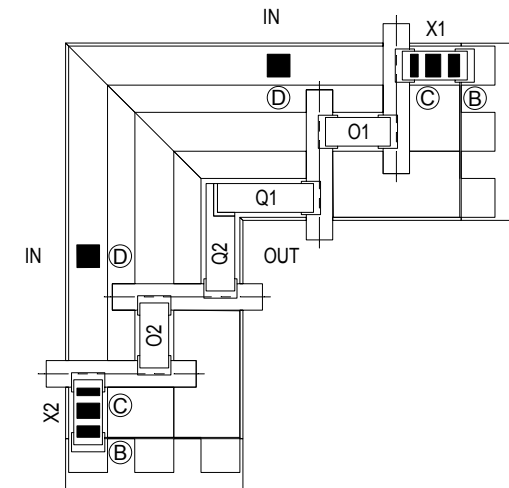

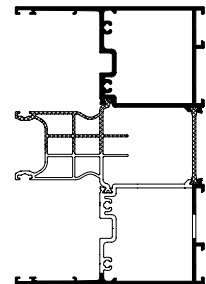
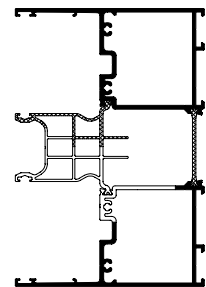
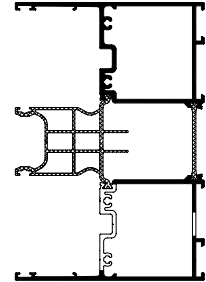
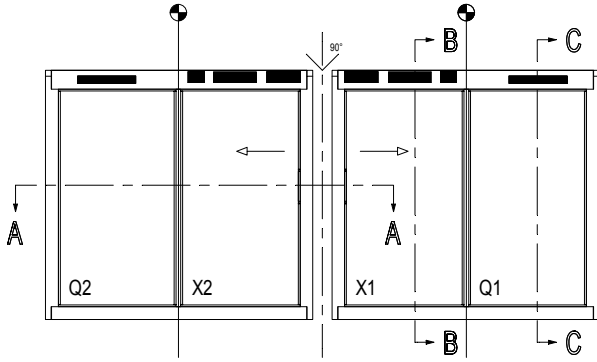

## Outside Corner QXVXQ

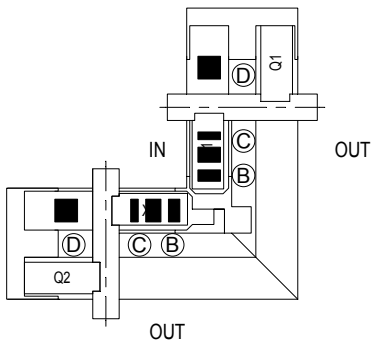

	095.C300.00
of / ou / or / oder	
	095.N000.00

+

	095.C321.00
--	-------------

MONTAGEVOLGORDE L'ORDRE DE MONTAGE THE ORDER OF ASSEMBLY MONTAGEREIHENFOLGE	1	2	3	.
--	---	---	---	---

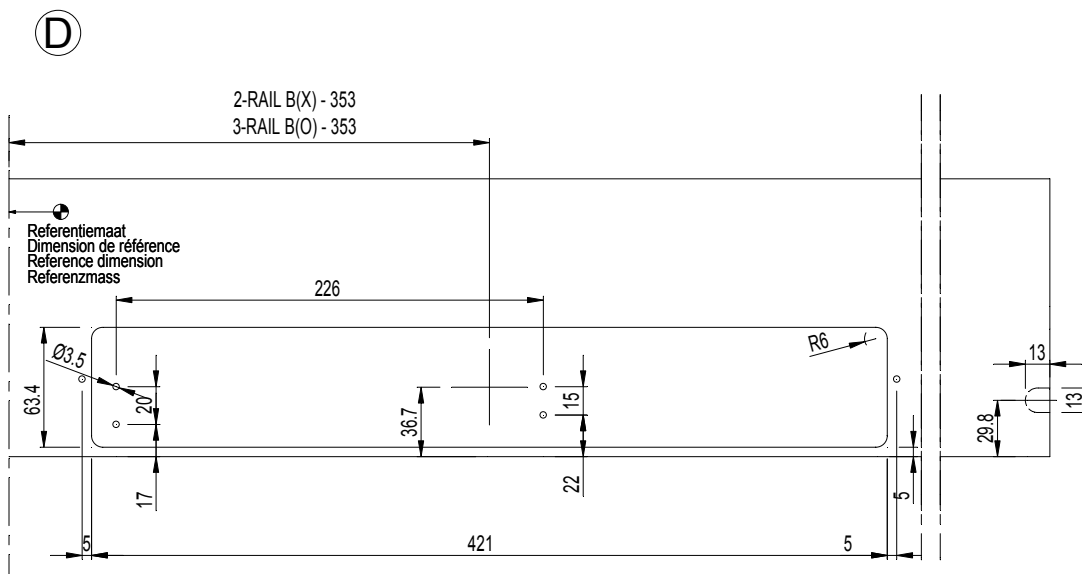
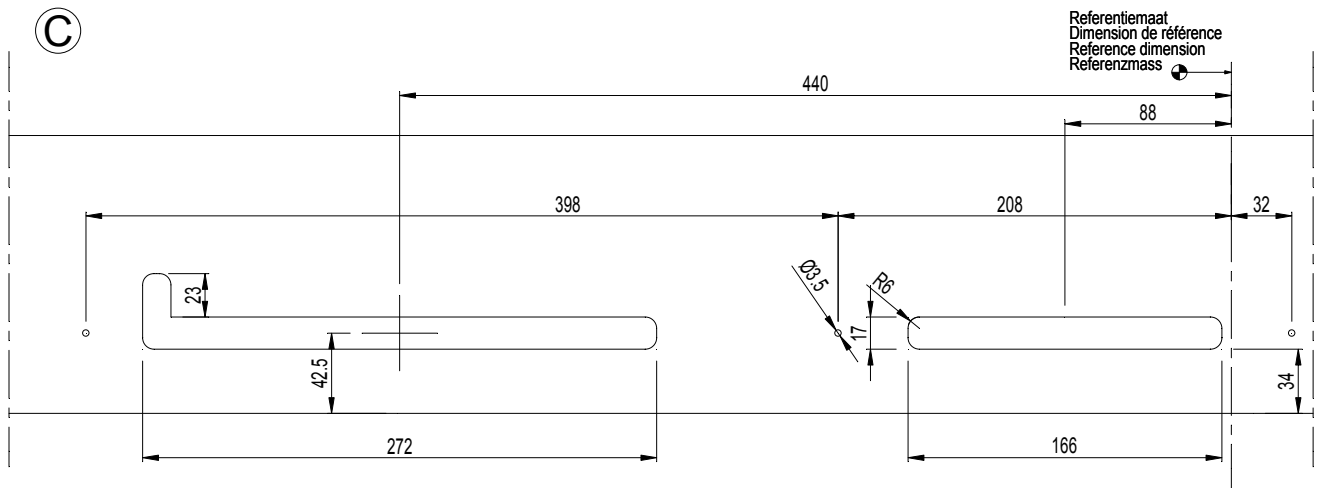
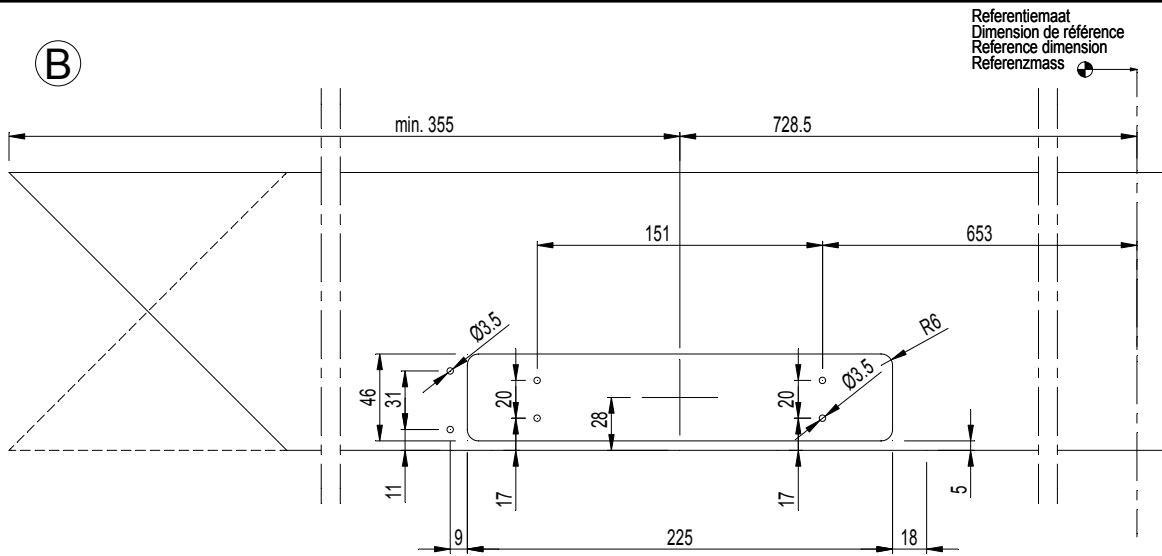

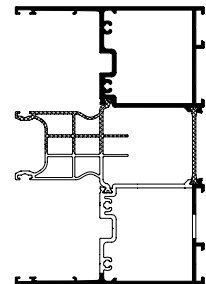
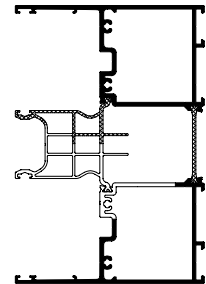
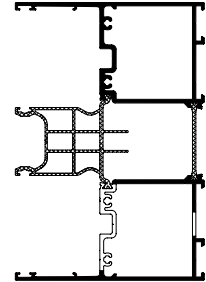
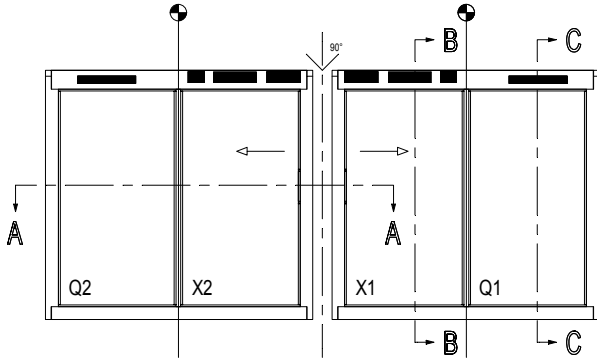

## Inside Corner

QXVXQ

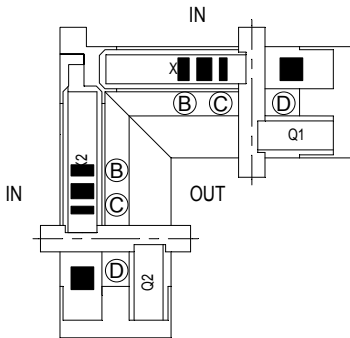

	095.C300.00
of / ou / or / oder	
	095.N000.00

+

	095.C321.00
--	-------------

MONTAGEVOLGORDE L'ORDRE DE MONTAGE THE ORDER OF ASSEMBLY MONTAGEREIHENFOLGE	1	2	3	.
--	---	---	---	---

**B**

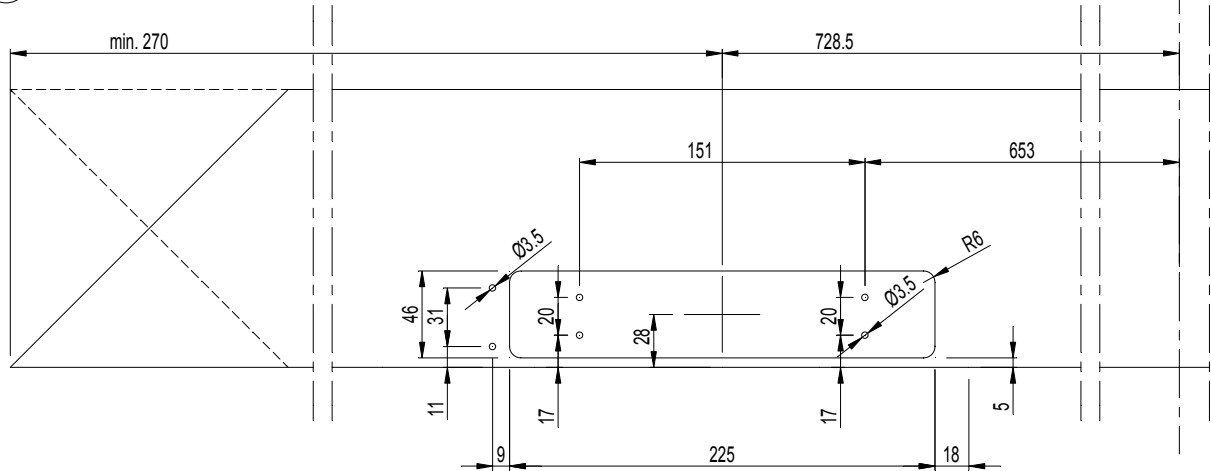

Referentiemaat  
 Dimension de référence  
 Reference dimension  
 Referenzmass

**C**

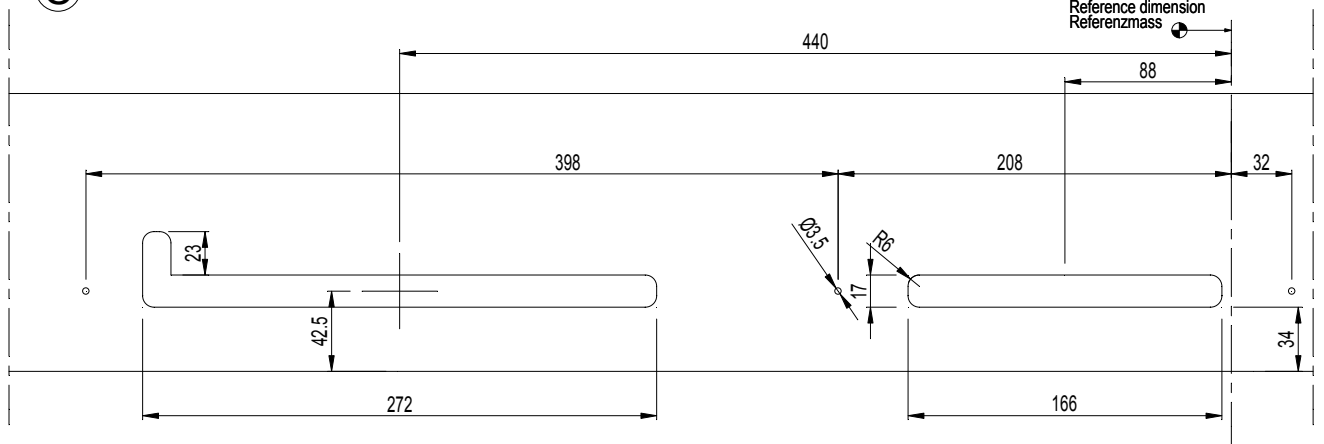

Referentiemaat  
 Dimension de référence  
 Reference dimension  
 Referenzmass

**D**

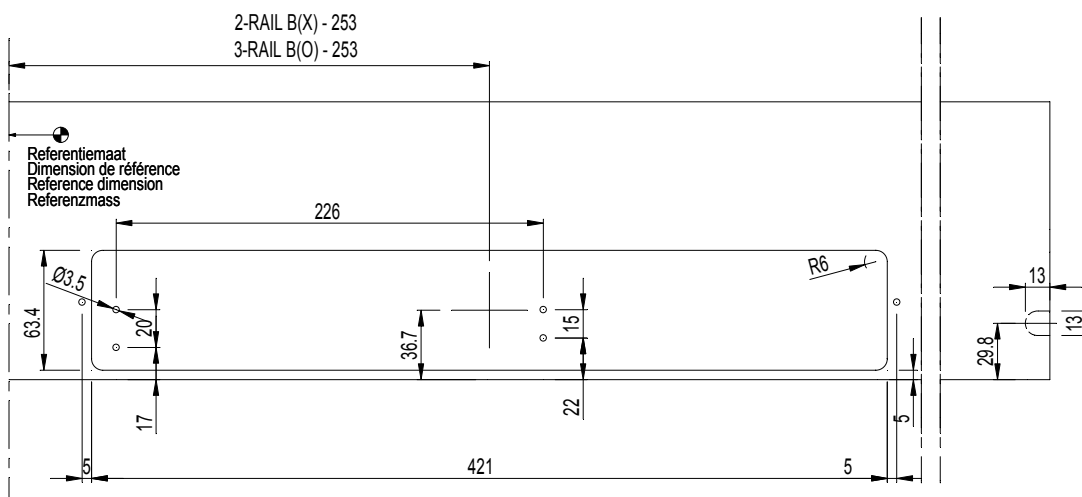

Referentiemaat  
 Dimension de référence  
 Reference dimension  
 Referenzmass

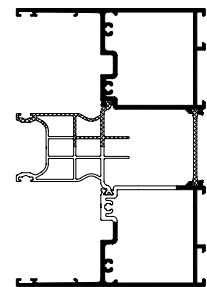
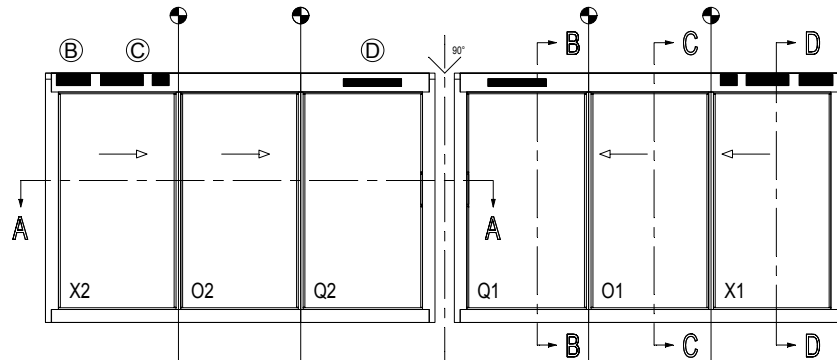
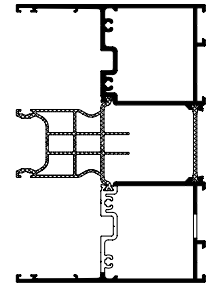
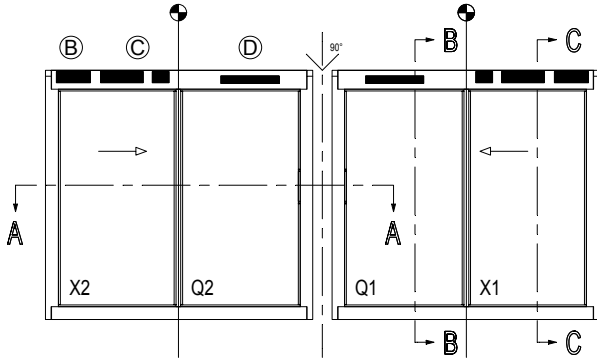

### Outside Corner XQVQX

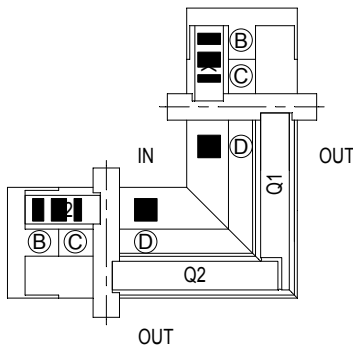

### Outside Corner XQVQOX

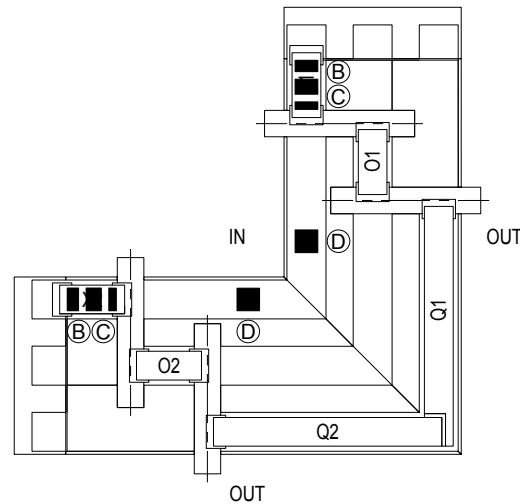

	095.C300.00
of / ou / or / oder	
	095.N000.00

	095.C321.00
--	-------------

MONTAGEVOLGORDE L'ORDRE DE MONTAGE THE ORDER OF ASSEMBLY MONTAGEREIHENFOLGE	1	2	3	.
--	---	---	---	---



**(B)**

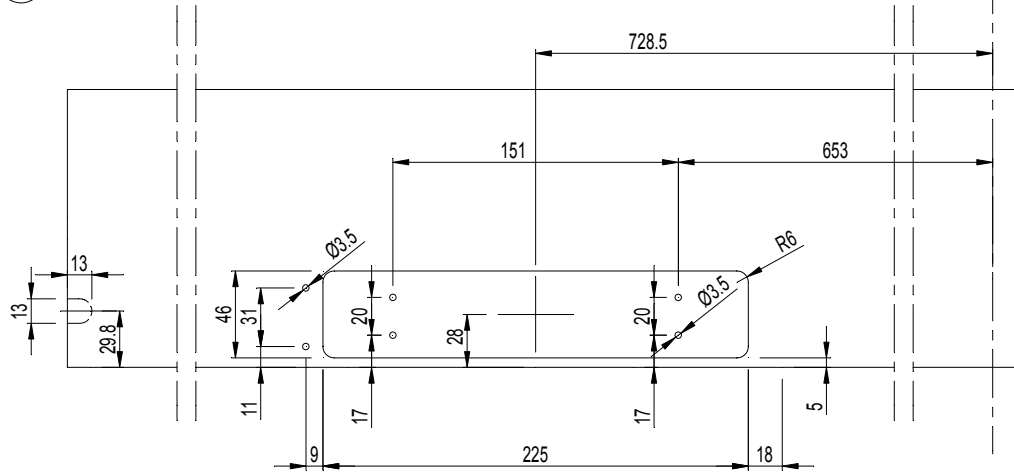

Referentiemaat  
 Dimension de référence  
 Reference dimension  
 Referenzmass

**(C)**

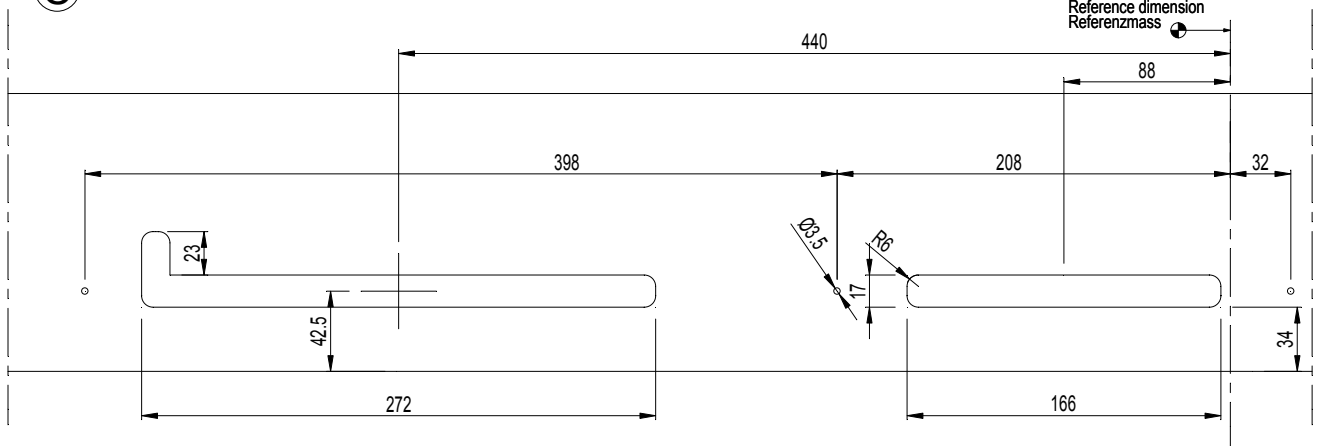

Referentiemaat  
 Dimension de référence  
 Reference dimension  
 Referenzmass

**(D)**

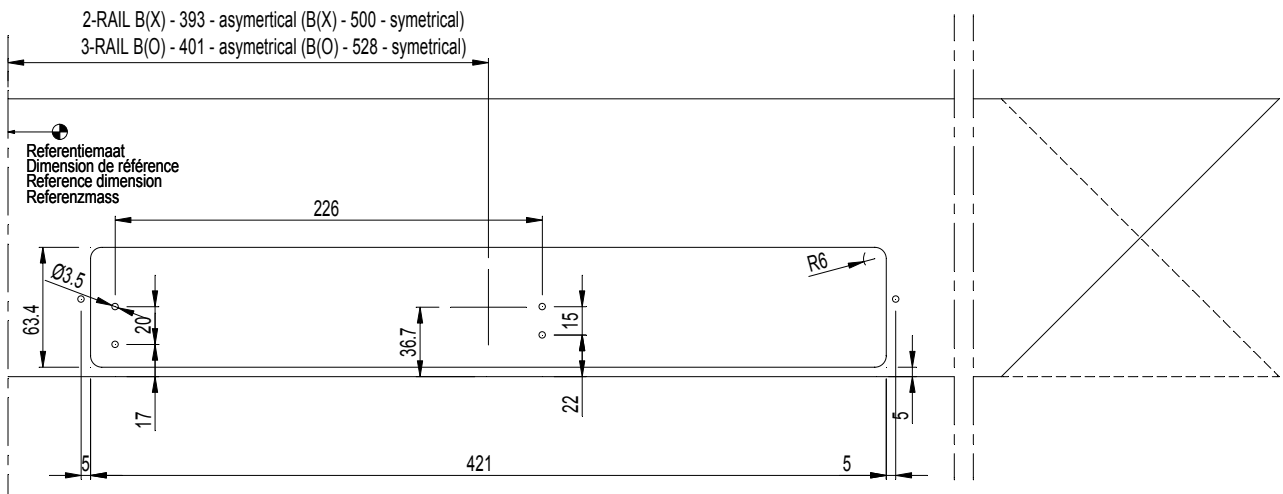

Referentiemaat  
 Dimension de référence  
 Reference dimension  
 Referenzmass

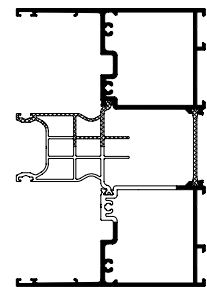
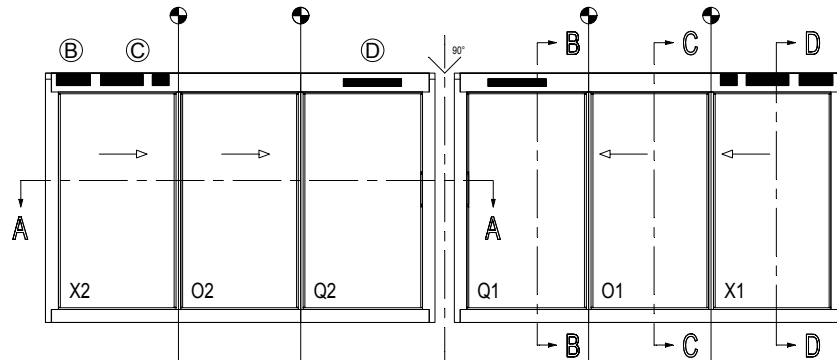
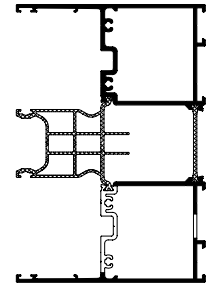
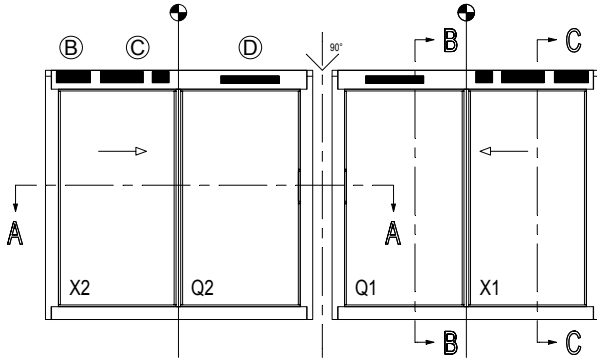

### Inside Corner XQVQX

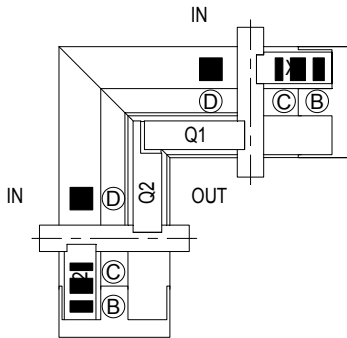

### Inside Corner XOQVQOX

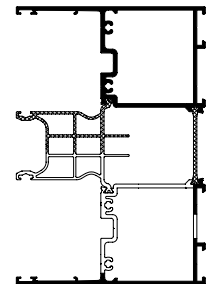
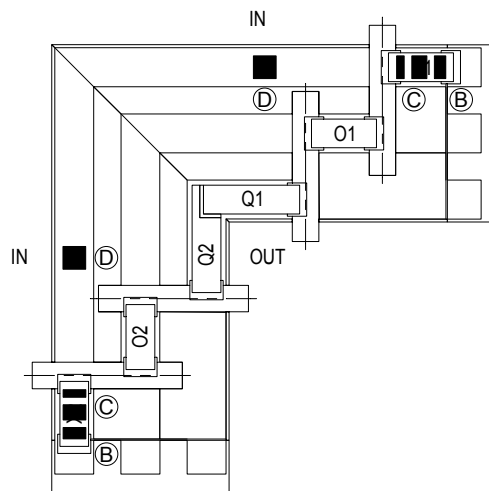

	095.C300.00
of / ou / or / oder	
	095.N000.00

+

	095.C321.00
--	-------------

MONTAGEVOLGORDE L'ORDRE DE MONTAGE THE ORDER OF ASSEMBLY MONTAGEREIHENFOLGE	1	2	3	.
--	---	---	---	---

(B)

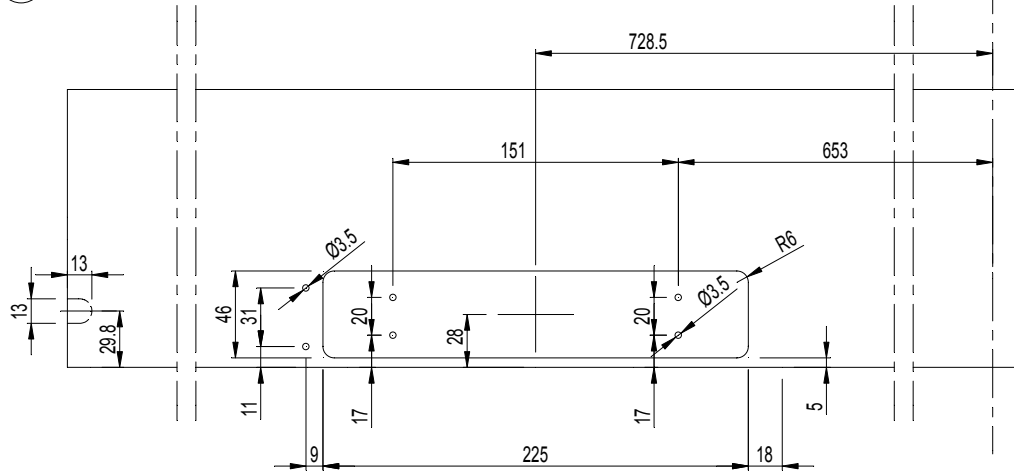

(C)

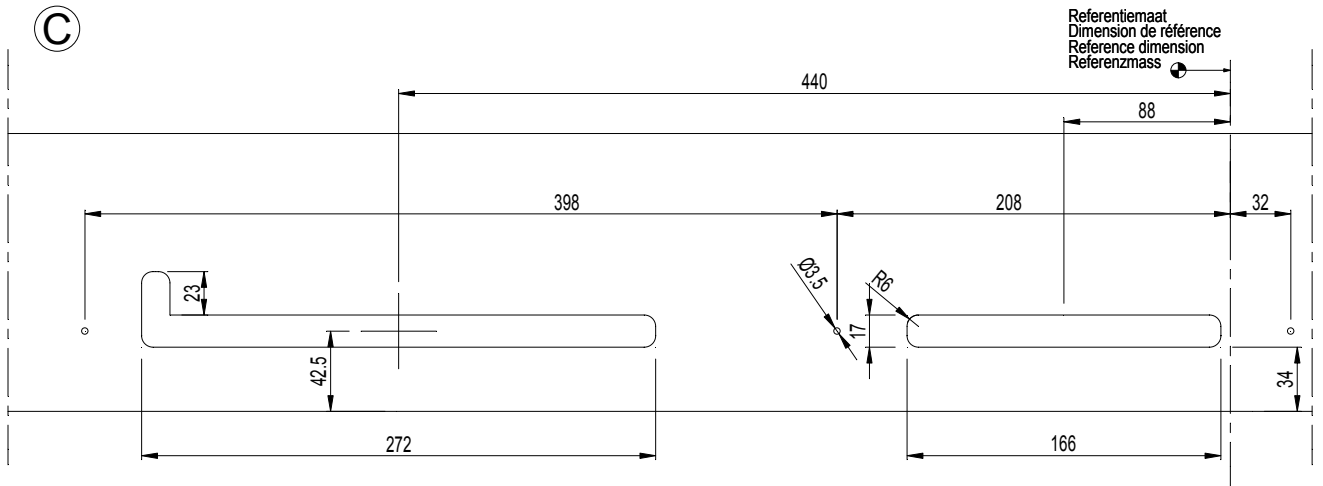

(D)

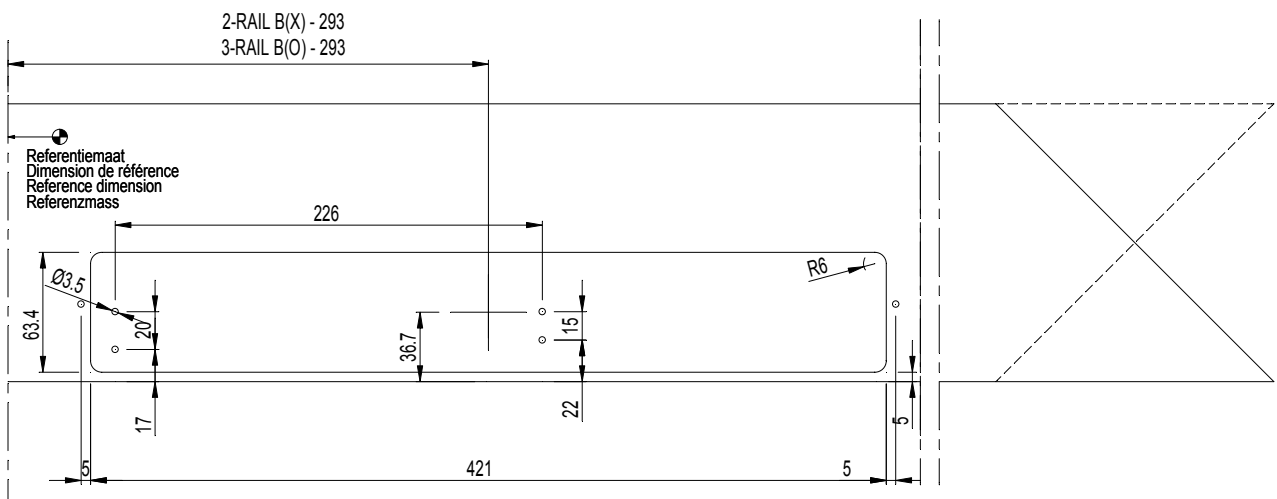

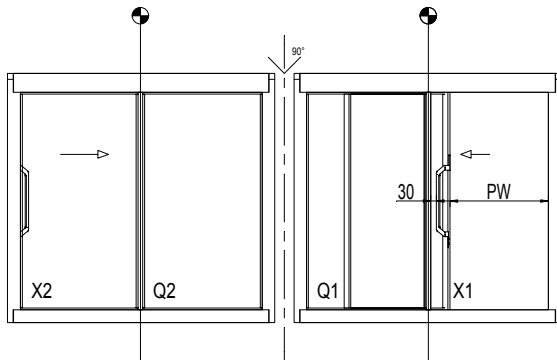

HFP 147:  $B(X)+B(Q)= \text{min. } 2000$   
 $b(Q) \geq b(X)$

Outside	Inside
$PW = B(X2) - 287$	$PW = B(X) - 187$

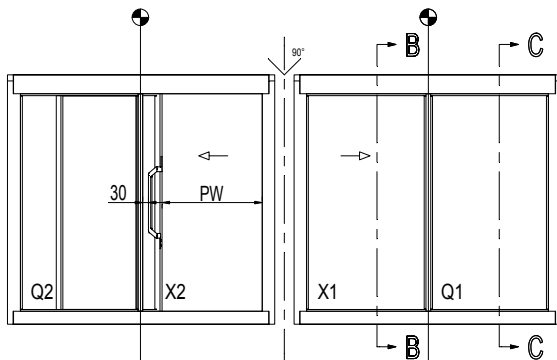

HFP 147:  $B(X)+B(Q)= \text{min. } 2000$   
 $b(Q) \geq b(X)$

Outside	Inside
$PW = B(X) - 281.5$	$PW = B(X) - 194$

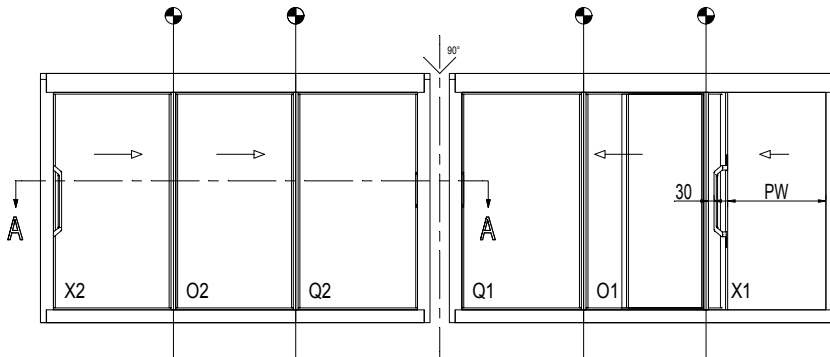

$B(X)+B(O)+B(Q)= \text{min. } 3000$   
 $b(Q) \geq b(O) \geq b(X)$

Outside	Inside
$PW = B(X) - 187$	$PW = B(X) - 187$

PW = PASSAGE WIDTH

MIN. SLIDING VENT [mm]

	FIXED CORNER		OPENING CORNER	
	Outside	Inside	Outside	Inside
2-RAIL	957	913	935	929
3-RAIL	966	908	---	---

**Outside Corner**  
 XQVQX

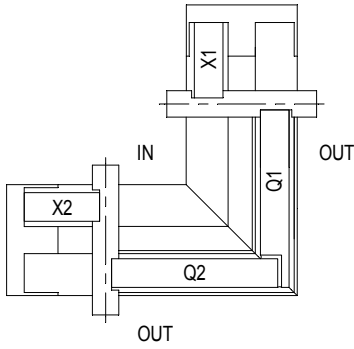

**Inside Corner**  
 XQVQX

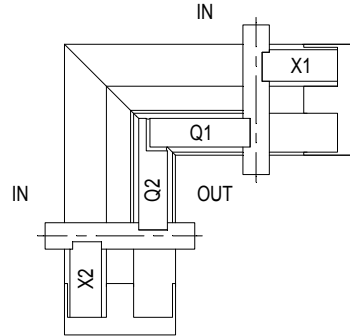

**Outside Corner**  
 QXVXQ

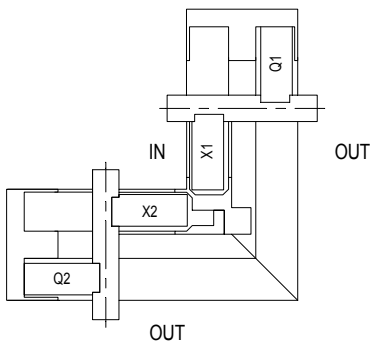

**Inside Corner**  
 QXVXQ

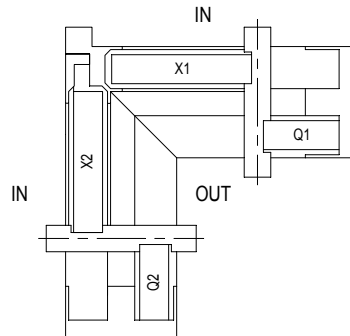

**Outside Corner**  
 XOQVQOX

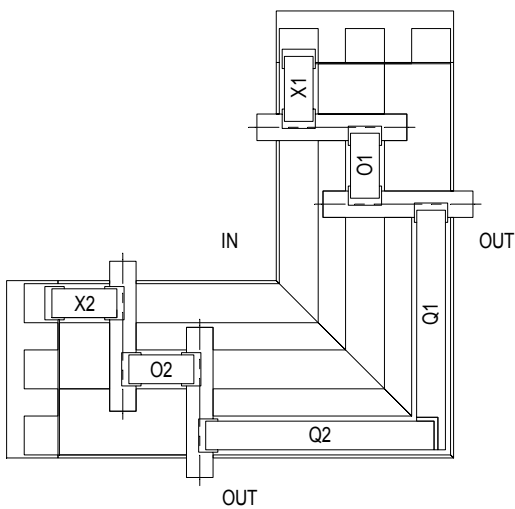

**Inside Corner**  
 XOQVQOX

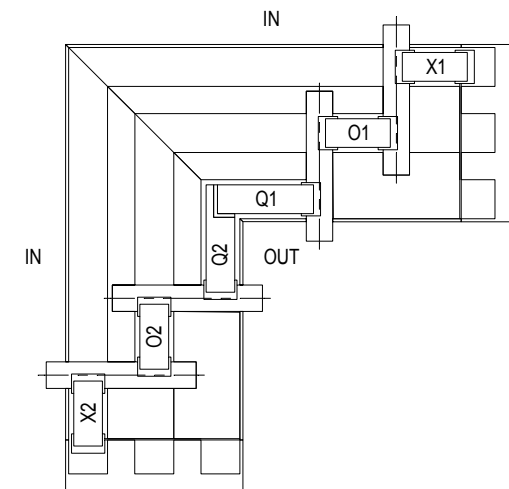

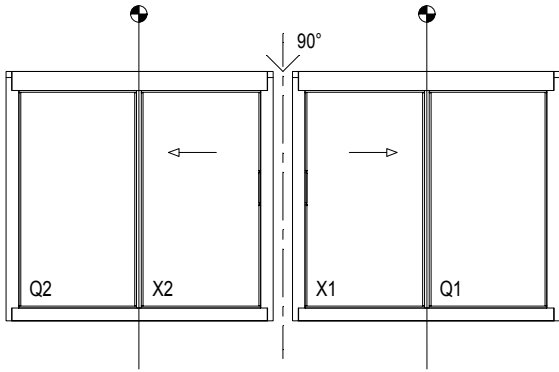

## Outside Corner

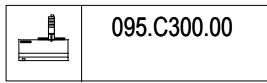
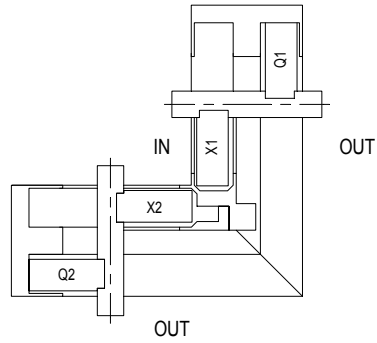

of / ou / or / oder

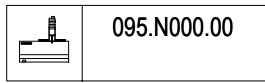

of / ou / or / oder

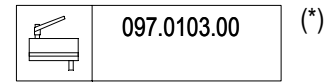

## View X

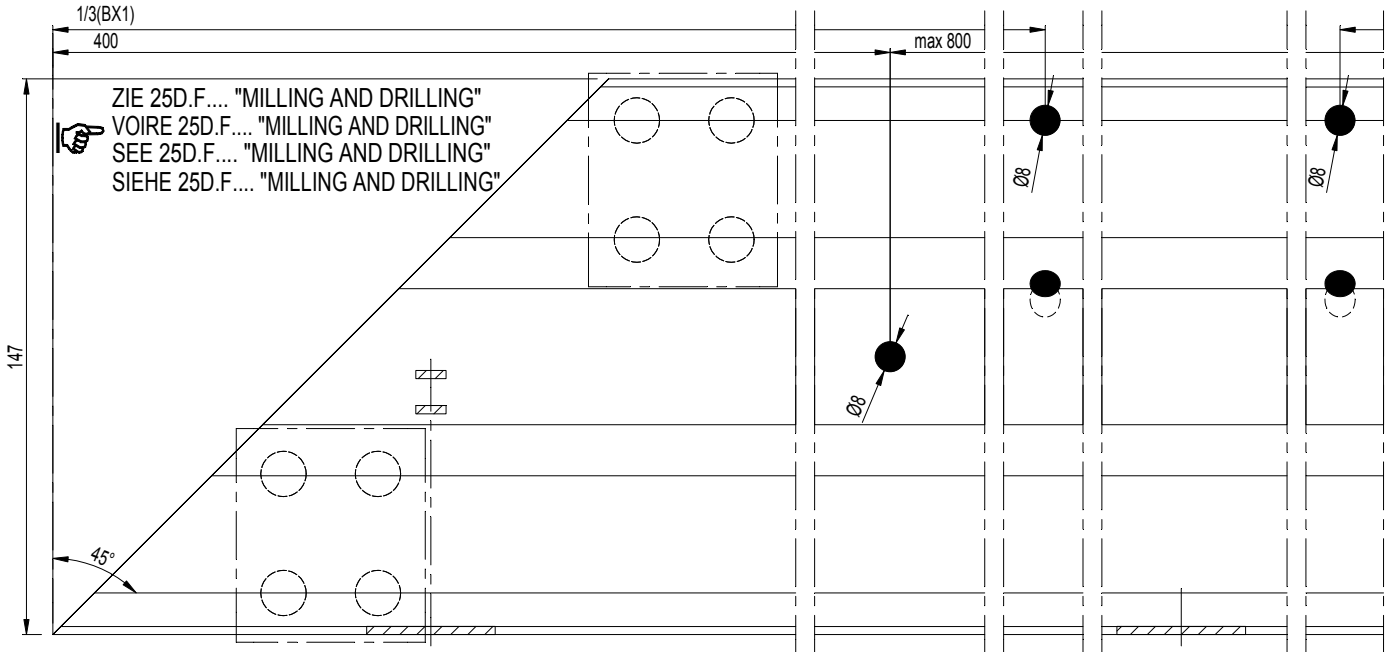

## View Y

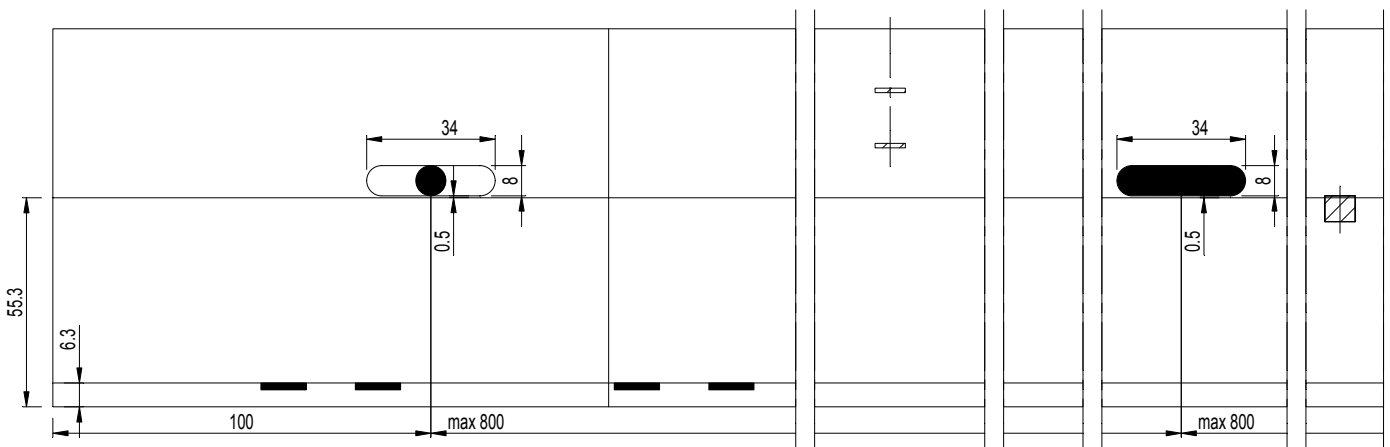

D2000457

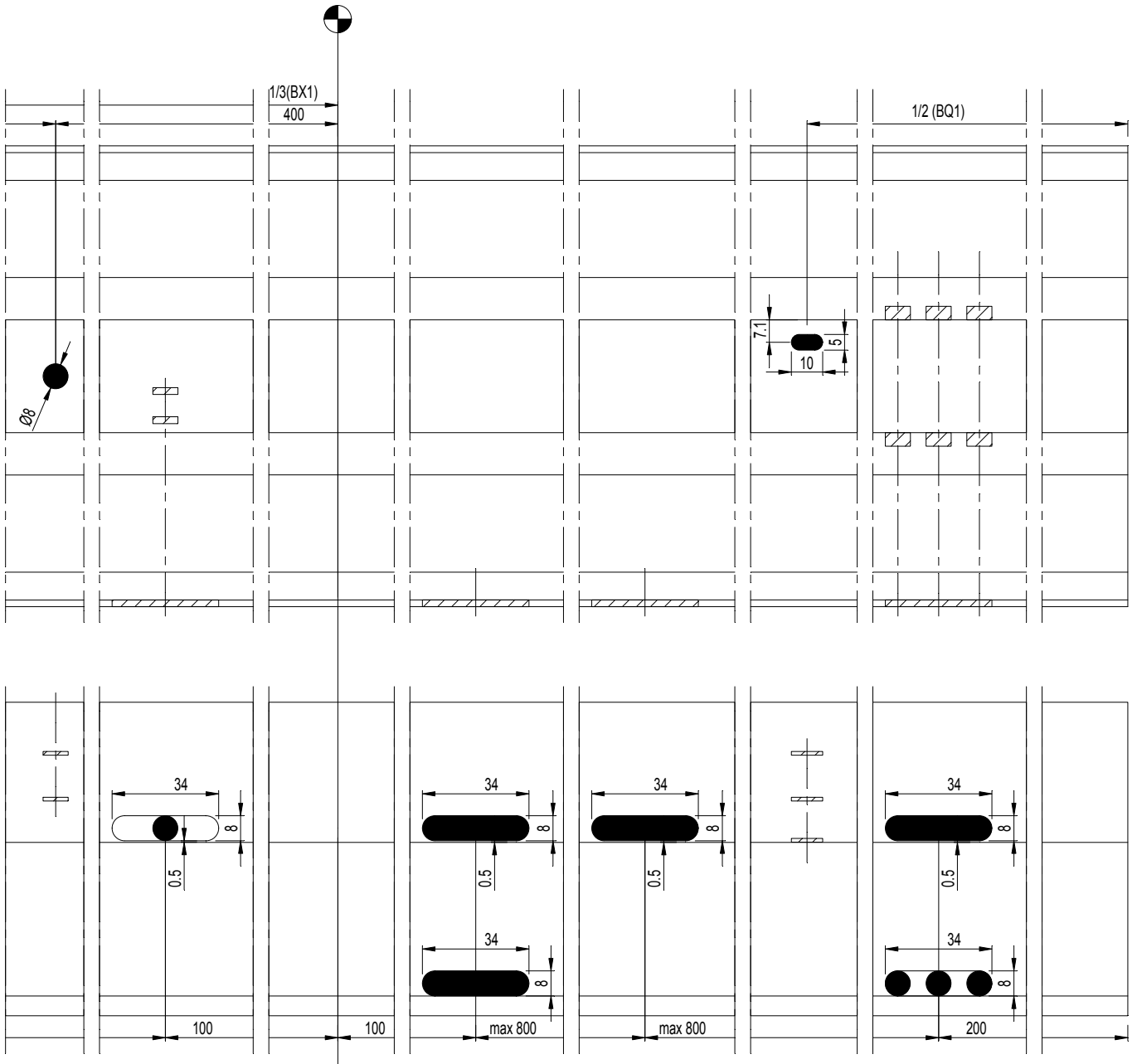
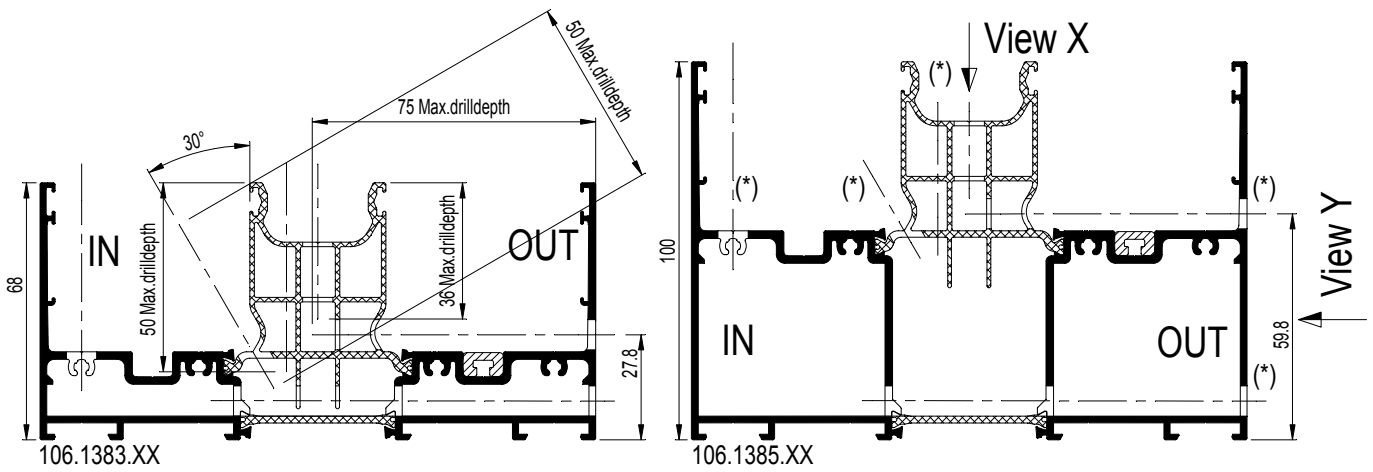

(\*) Ø 8

D2000457

## Outside Corner

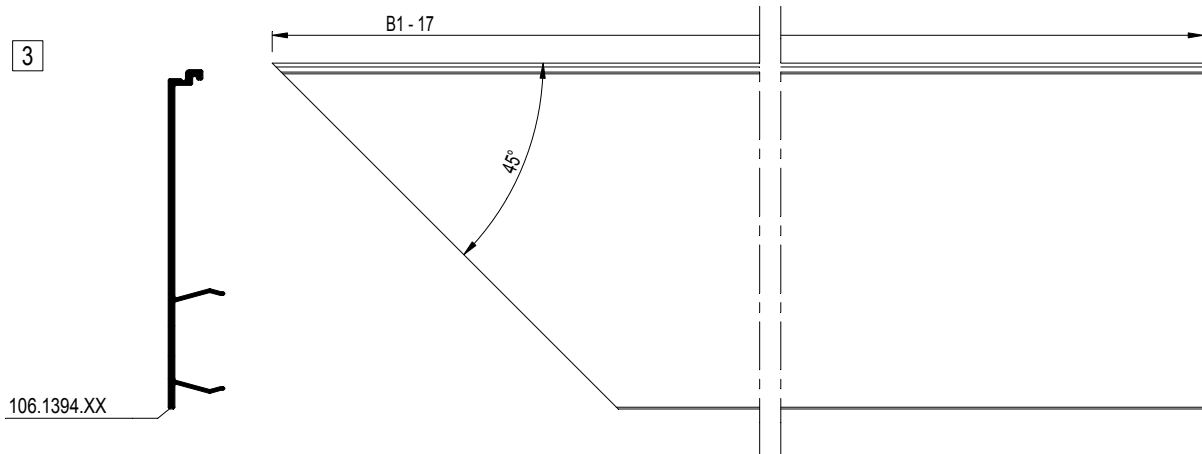
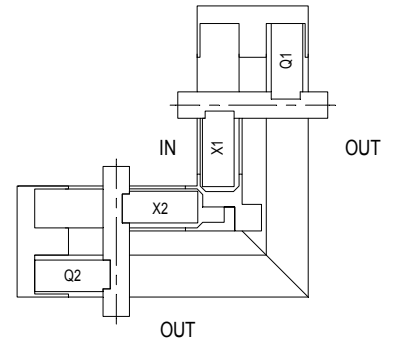
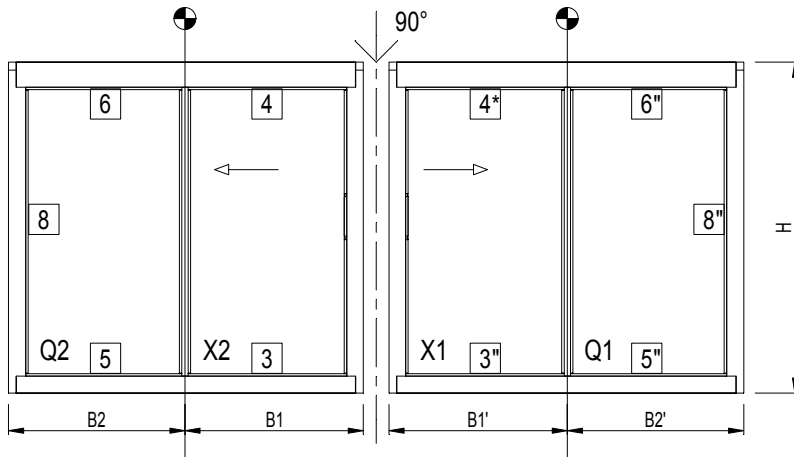

106.1394.XX

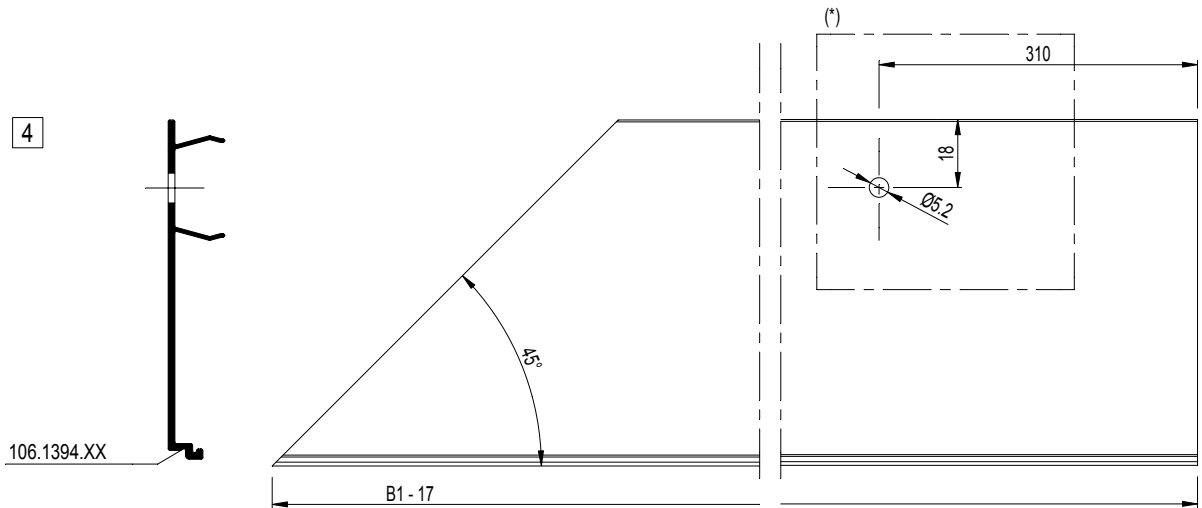

106.1394.XX

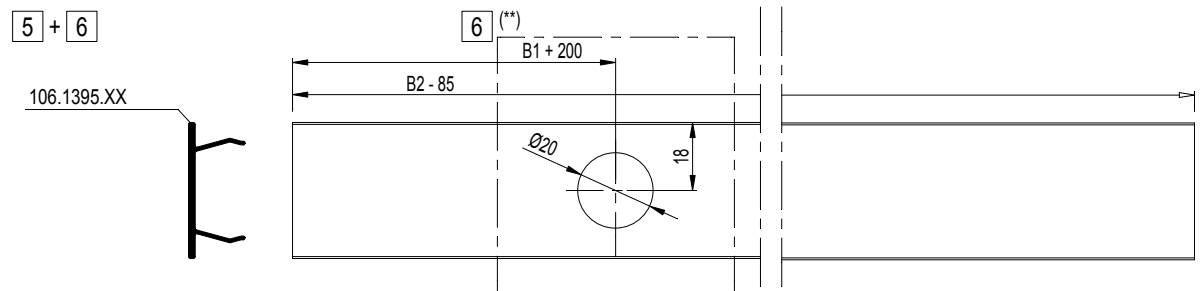

106.1395.XX

3" 4" 5" 6" 8" ARE MIRROR VERSION OF PROFILES IN PROPER LENGTH 3 4 5 6 8



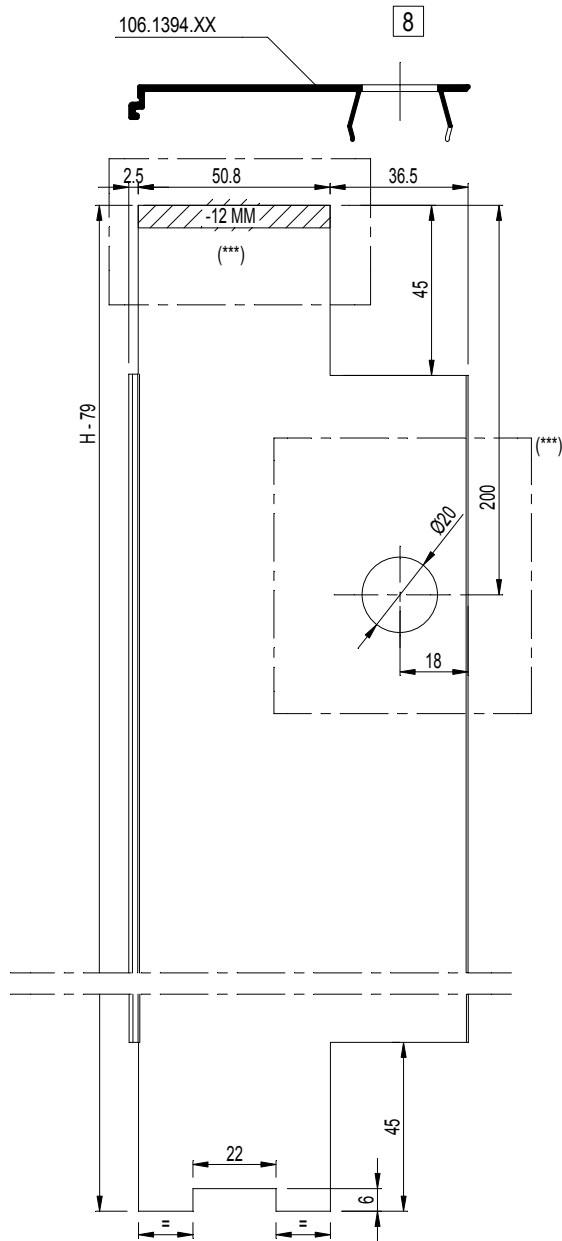

(\*) ENKEL VOOR MANUELE CONFIGURATIE  
 UNIQUEMENT POUR CONFIGURATION MANUELE  
 ONLY FOR MANUAL CONFIGURATION  
 NUR FUER MANUELE KONFIGURATIE

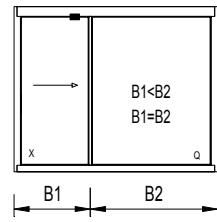

(\*\*) ENKEL VOOR MOTORISCHE CONFIGURATIE  
 UNIQUEMENT POUR CONFIGURATION MOTEUR  
 ONLY FOR MOTOR CONFIGURATION  
 NUR FUER MOTOR KONFIGURATIE

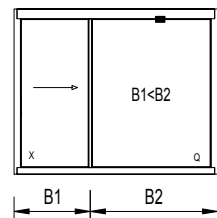

(\*\*\*) ENKEL VOOR MOTORISCHE CONFIGURATIE  
 UNIQUEMENT POUR CONFIGURATION MOTEUR  
 ONLY FOR MOTOR CONFIGURATION  
 NUR FUER MOTOR KONFIGURATIE

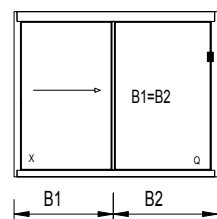

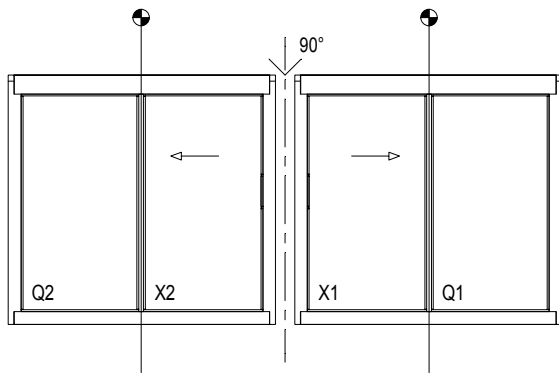

Inside Corner

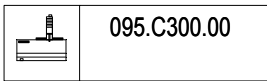
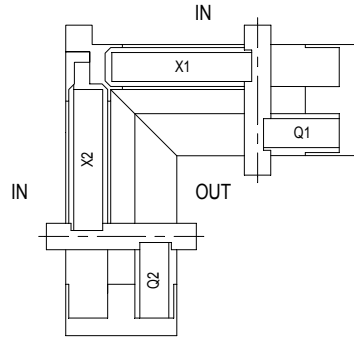

095.C300.00

of / ou / or / oder

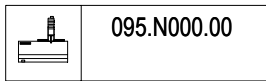

095.N000.00

of / ou / or / oder

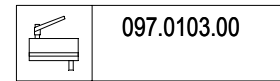

097.0103.00

(\*)

View X

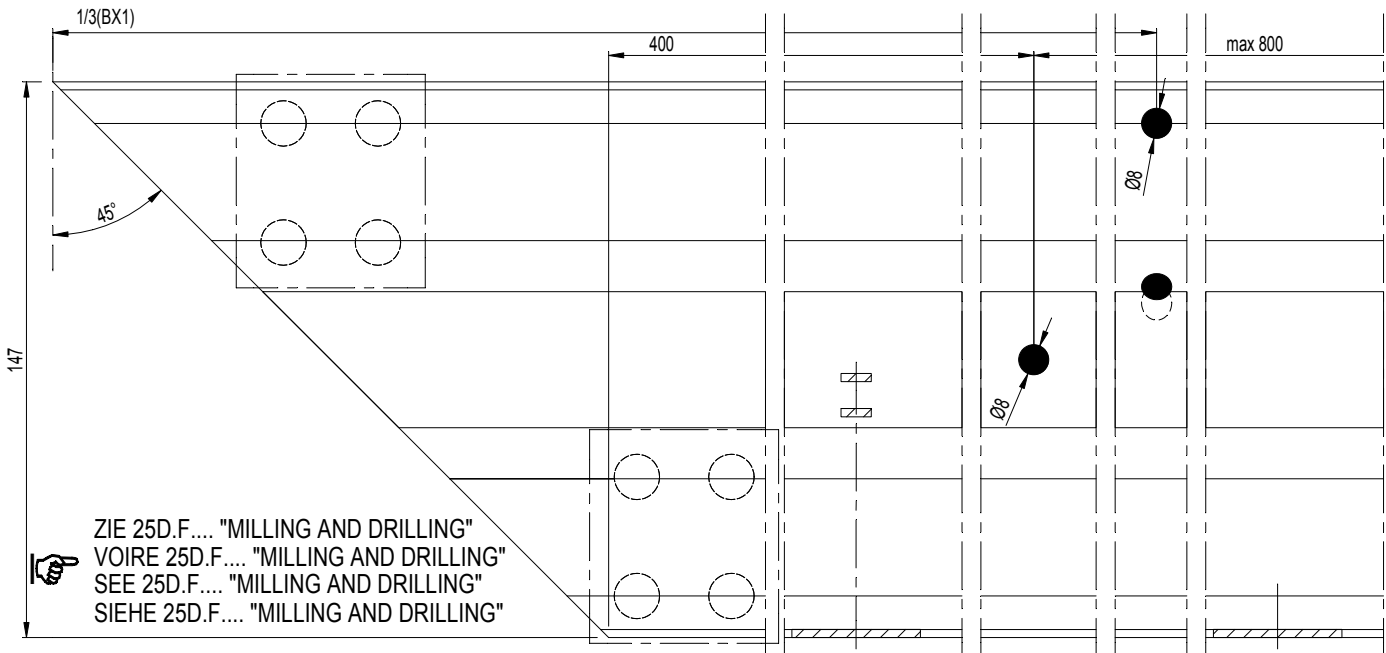

View Y

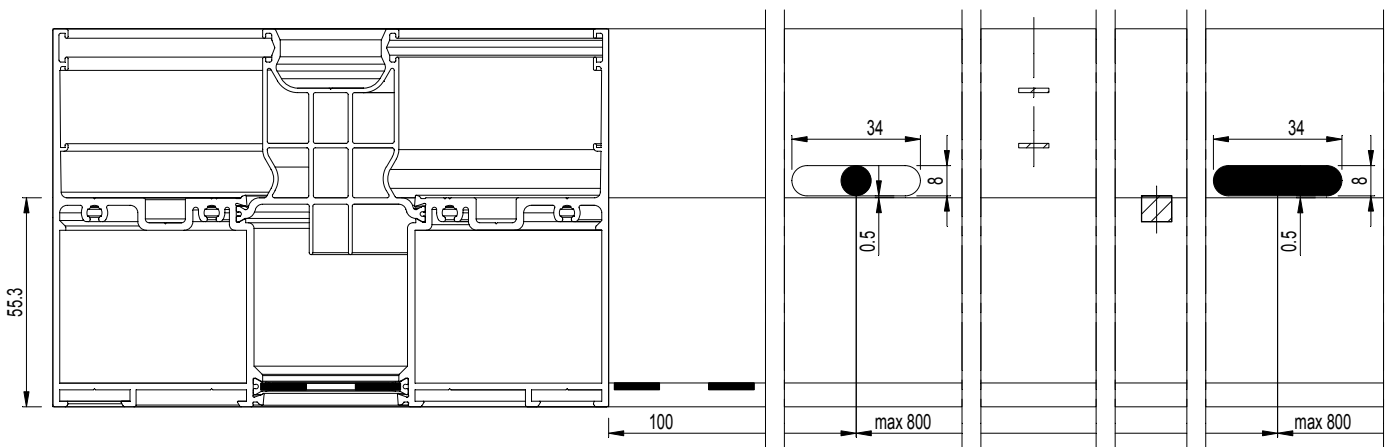

D2000458

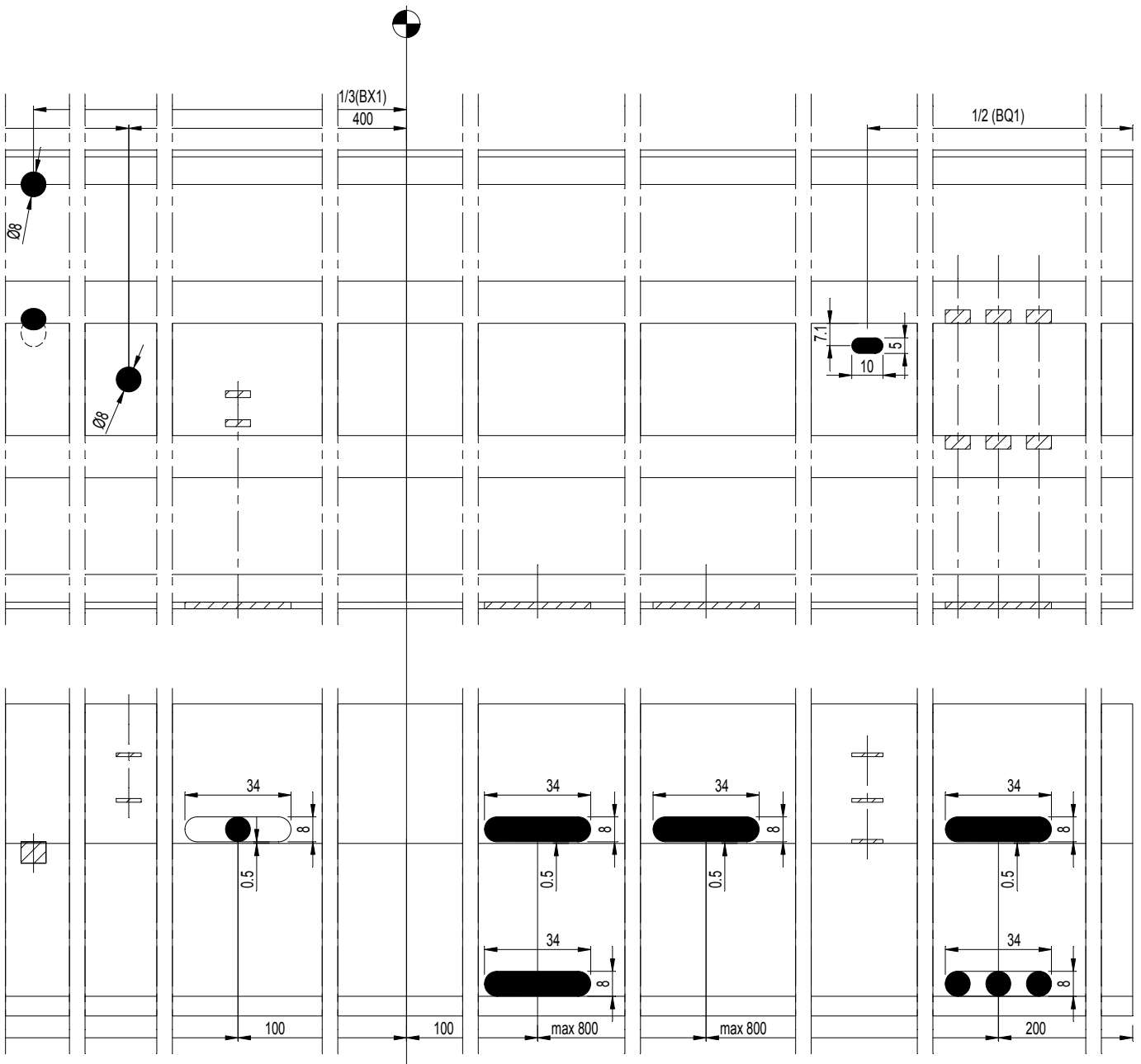
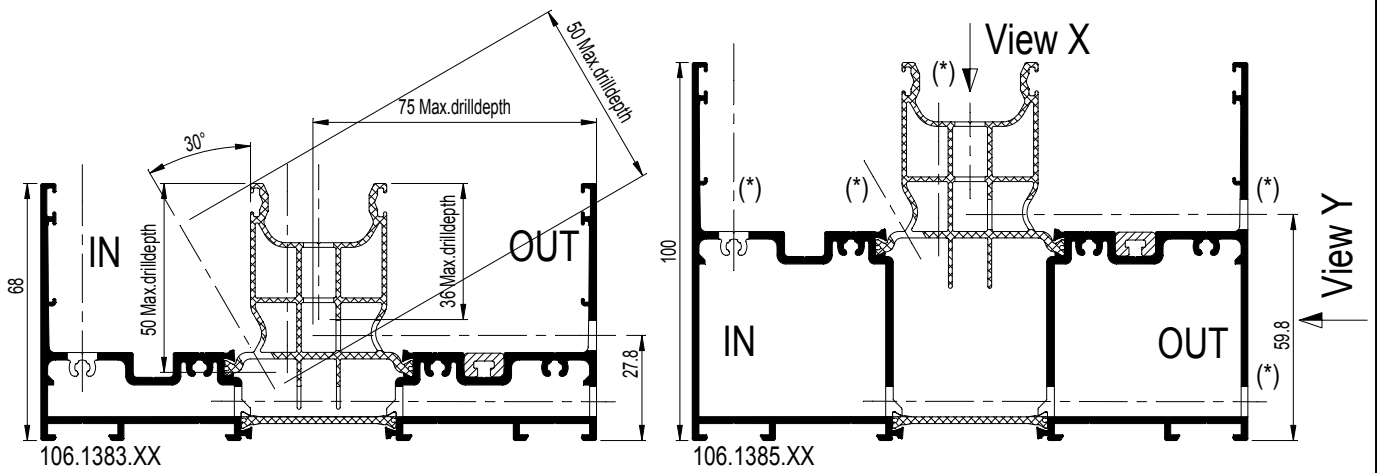

(\*) Ø 8

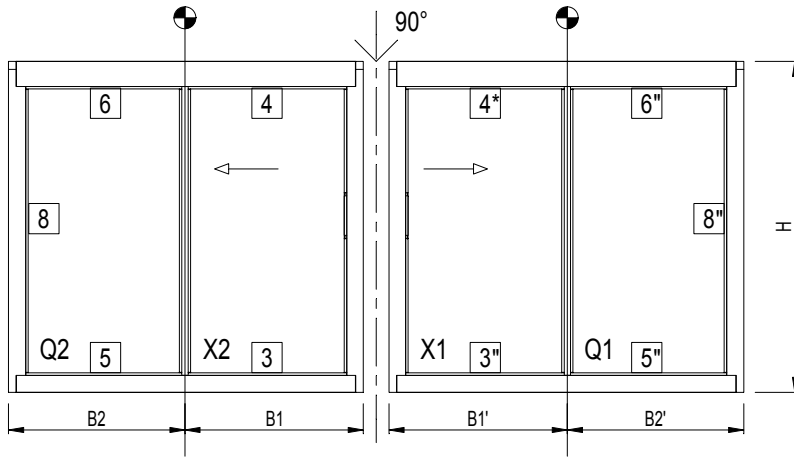

### Inside Corner

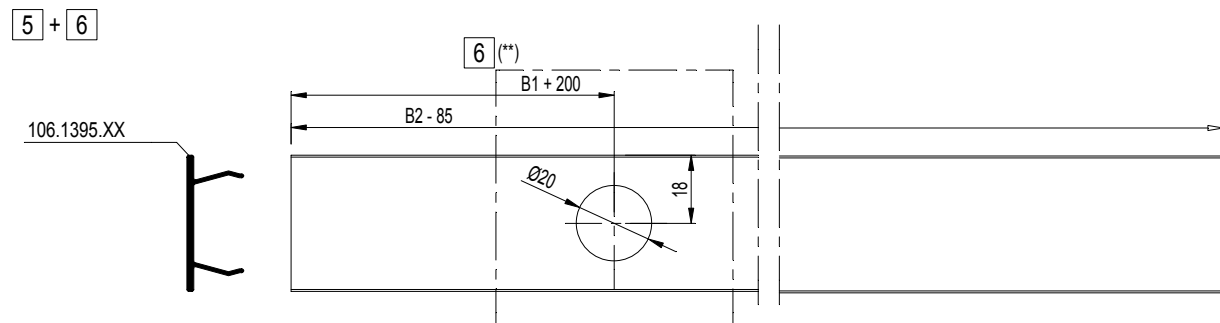
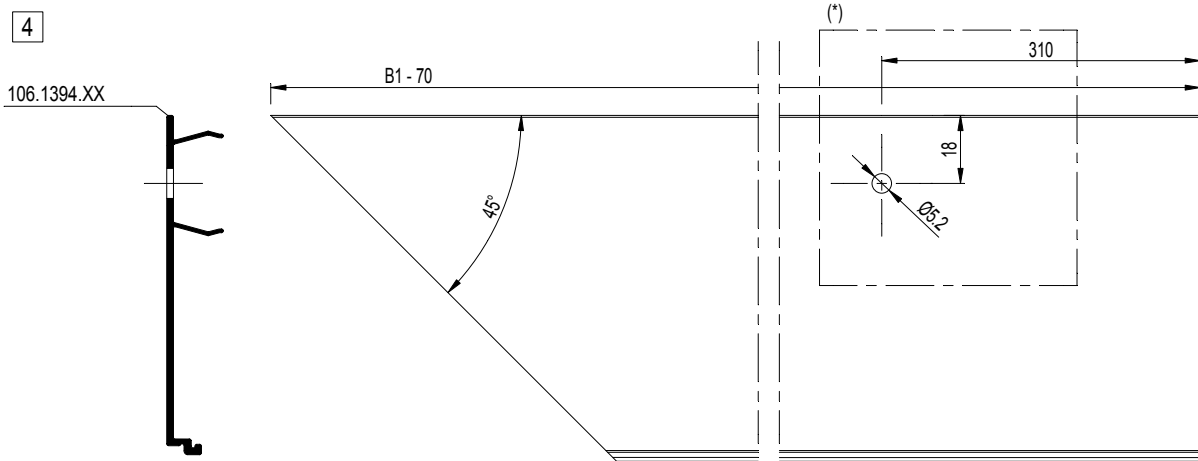
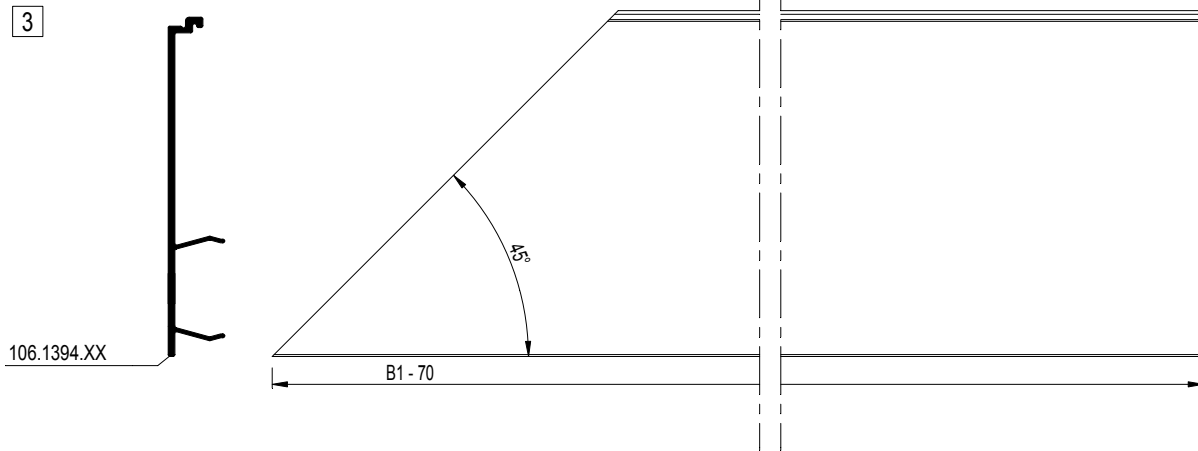
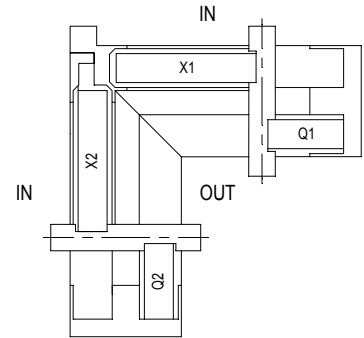

**3" 4" 5" 6" 8"** ARE MIRROR VERSION OF PROFILES **3 4 5 6 8**

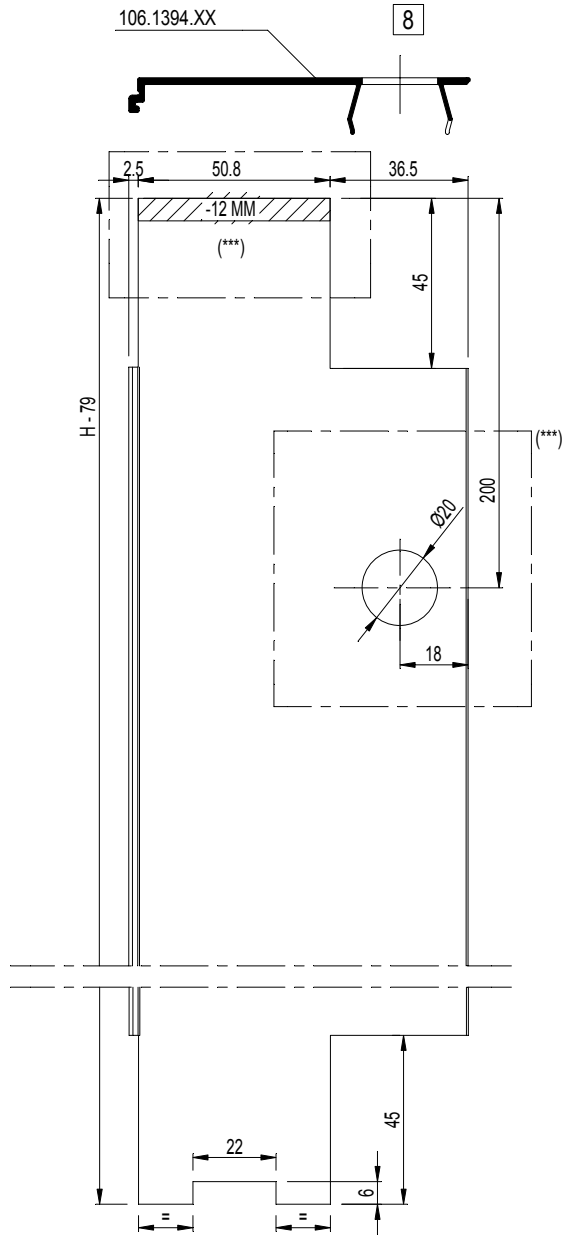

(\*) ENKEL VOOR MANUELE CONFIGURATIE  
 UNIQUEMENT POUR CONFIGURATION MANUELE  
 ONLY FOR MANUAL CONFIGURATION  
 NUR FUER MANUELE KONFIGURATIE

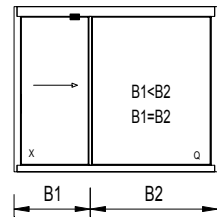

(\*\*) ENKEL VOOR MOTORISCHE CONFIGURATIE  
 UNIQUEMENT POUR CONFIGURATION MOTEUR  
 ONLY FOR MOTOR CONFIGURATION  
 NUR FUER MOTOR KONFIGURATIE

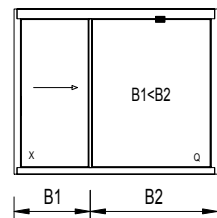

(\*\*\*) ENKEL VOOR MOTORISCHE CONFIGURATIE  
 UNIQUEMENT POUR CONFIGURATION MOTEUR  
 ONLY FOR MOTOR CONFIGURATION  
 NUR FUER MOTOR KONFIGURATIE

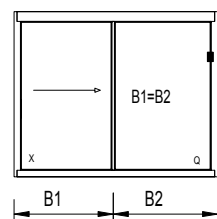

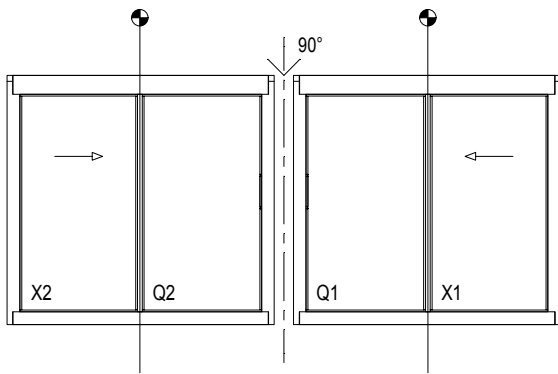

## Outside Corner

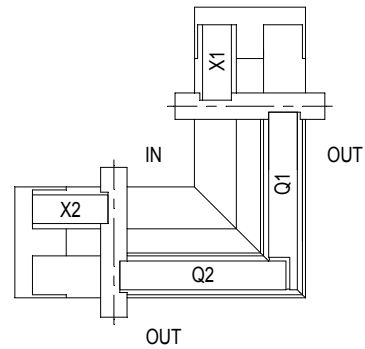

**095.C300.00**

of / ou / or / oder

**095.N000.00**

of / ou / or / oder

**097.0103.00 (\*)**

## View X

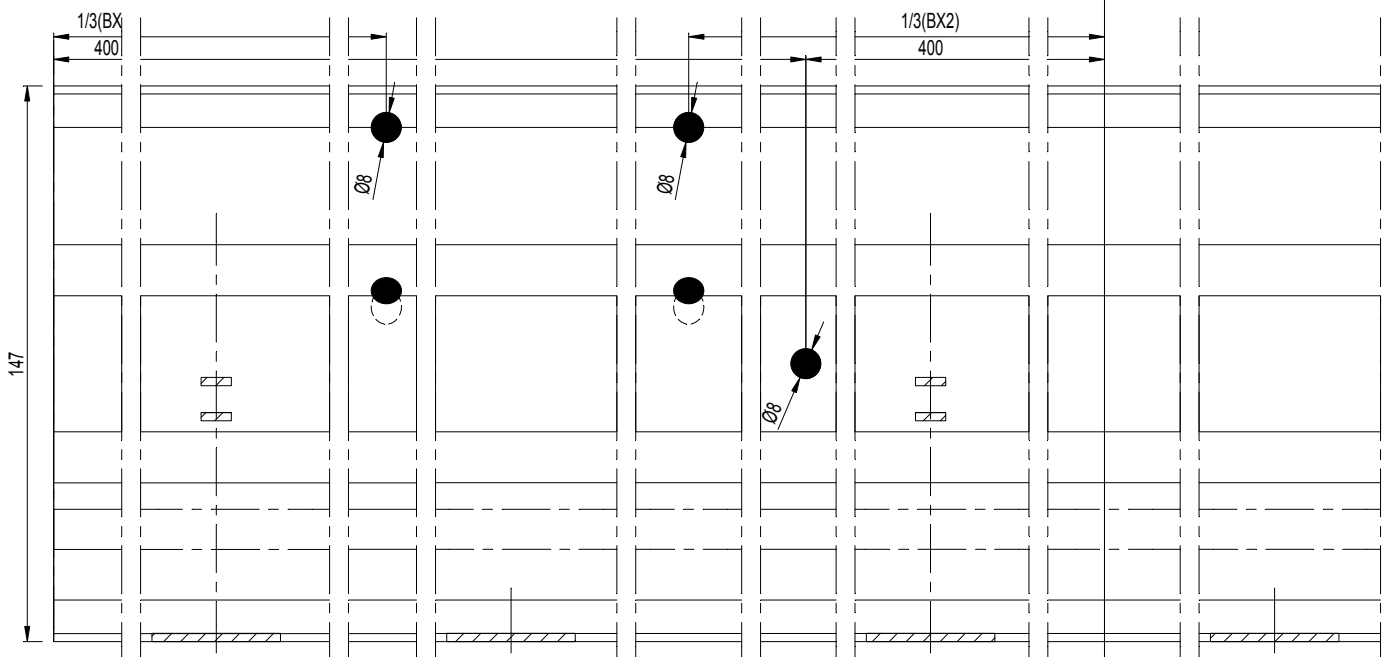

## View Y

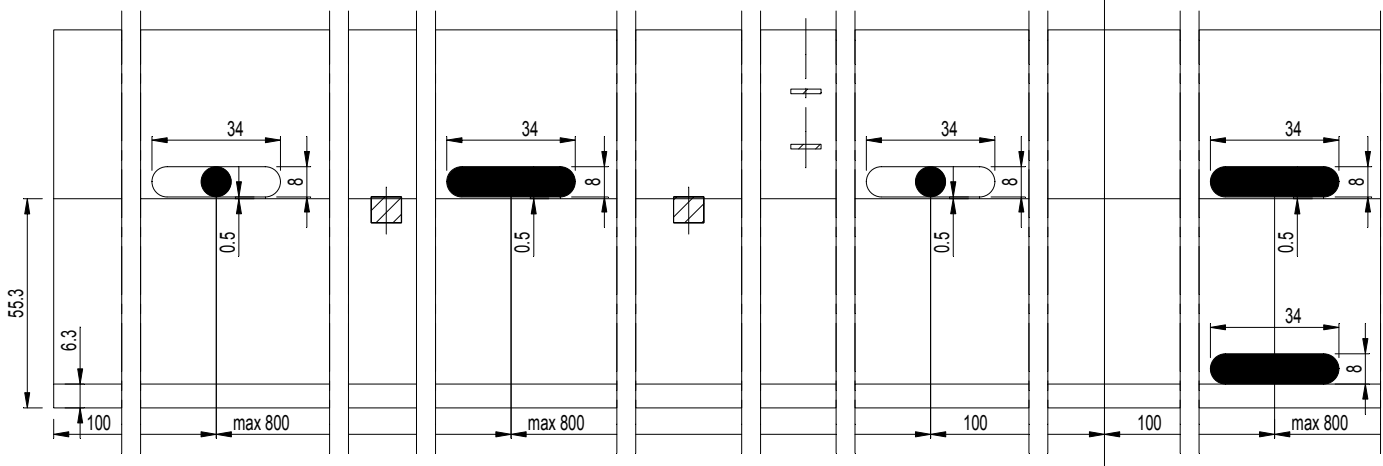

D2000486

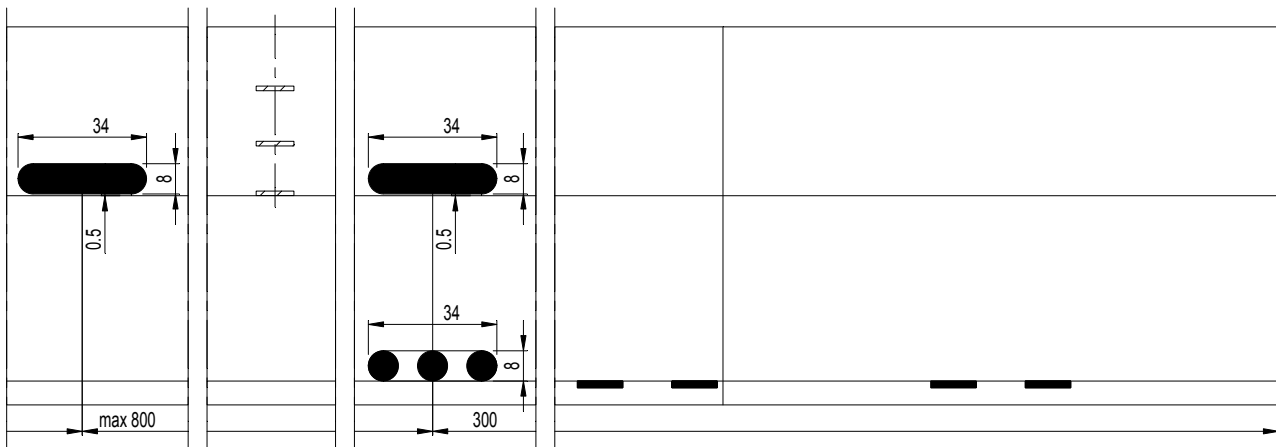
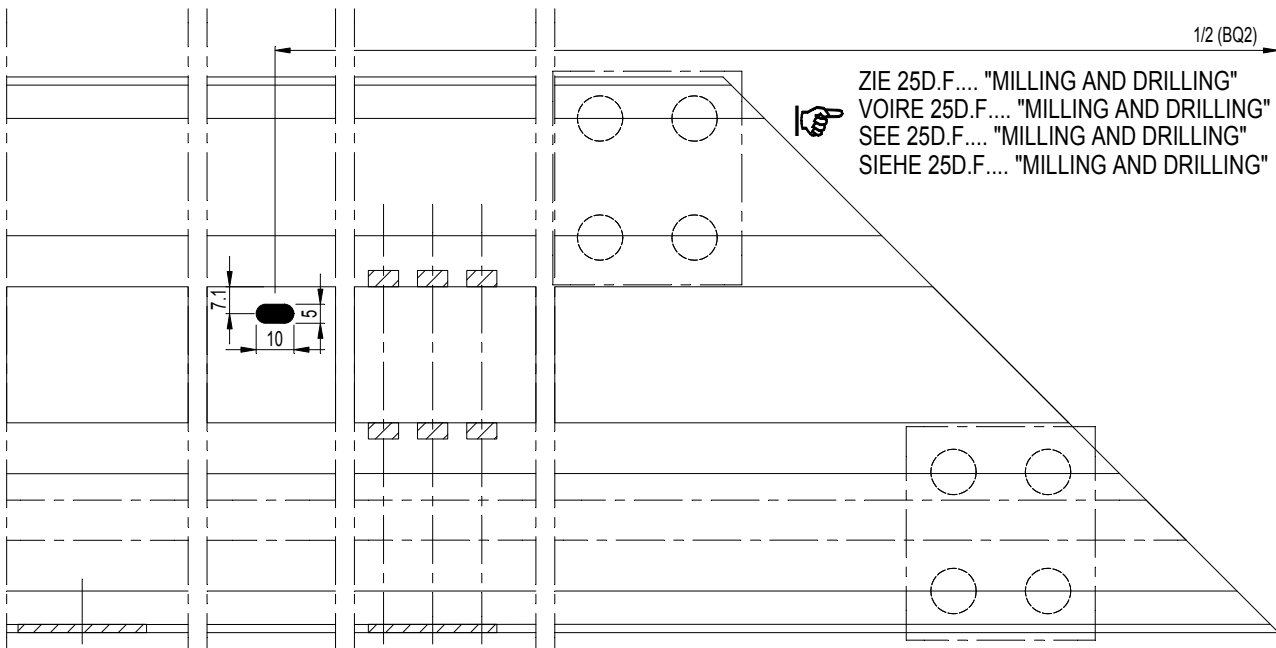
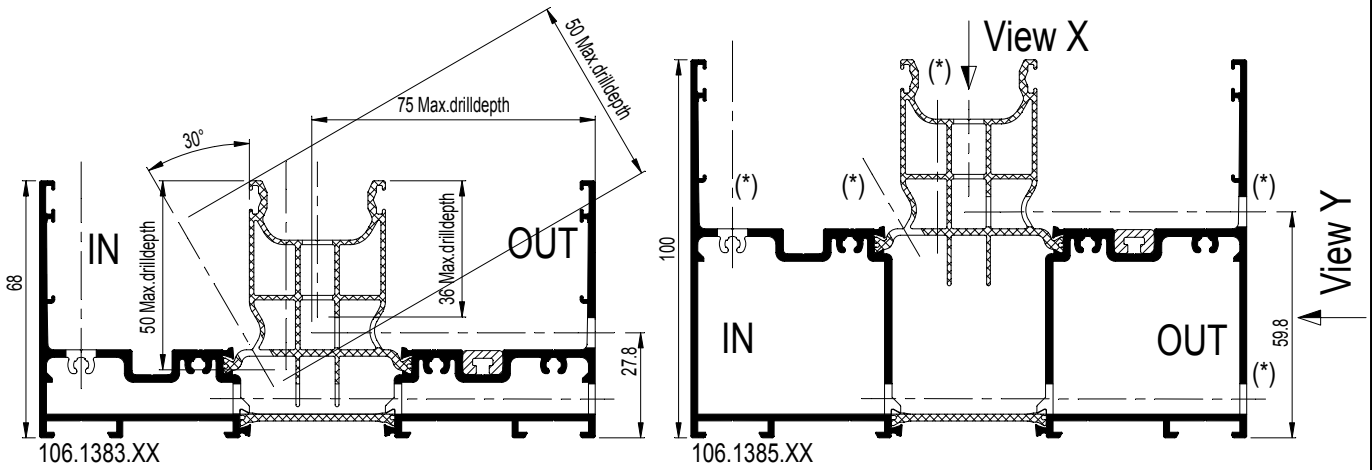

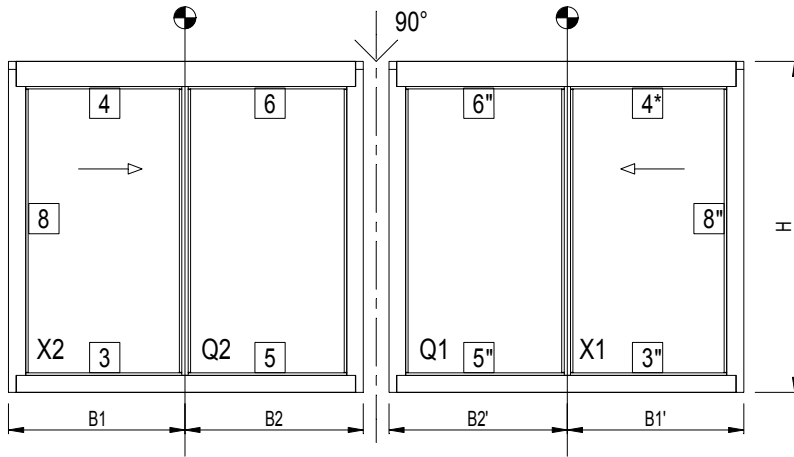

## Outside Corner

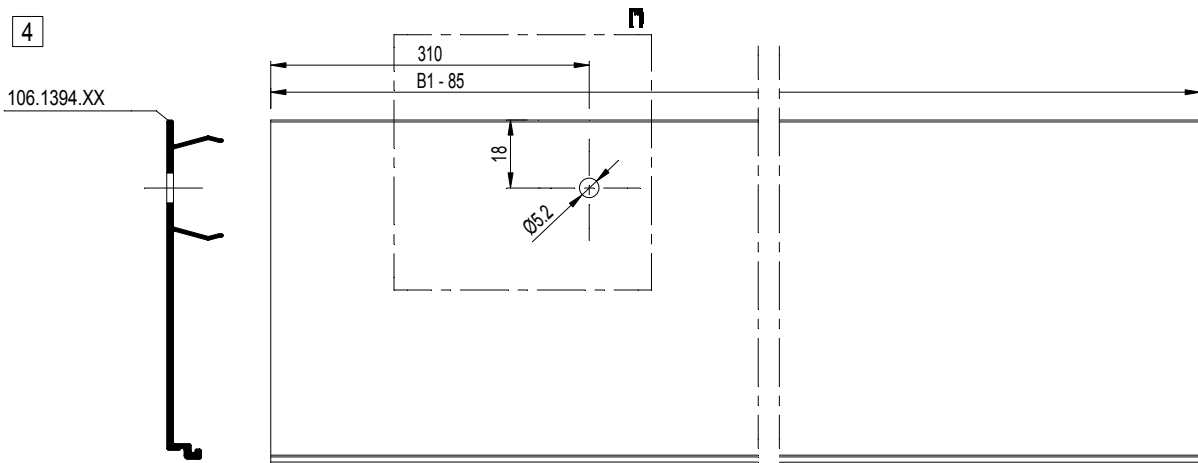
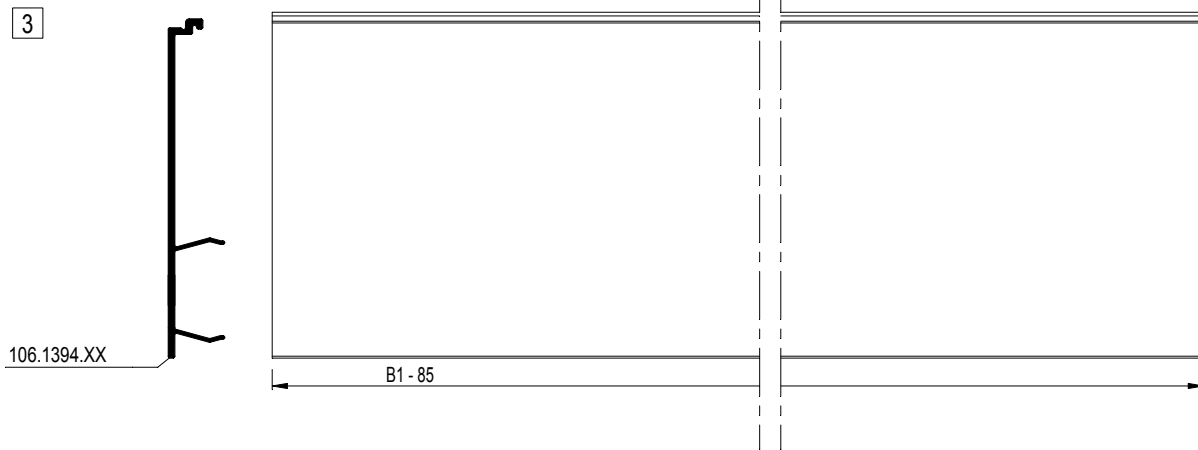
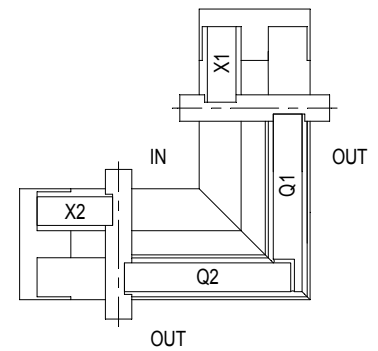

3 4 5 6 8 ARE MIRROR VERSION OF PROFILES 3 4 5 6 8



8

106.1394.XX

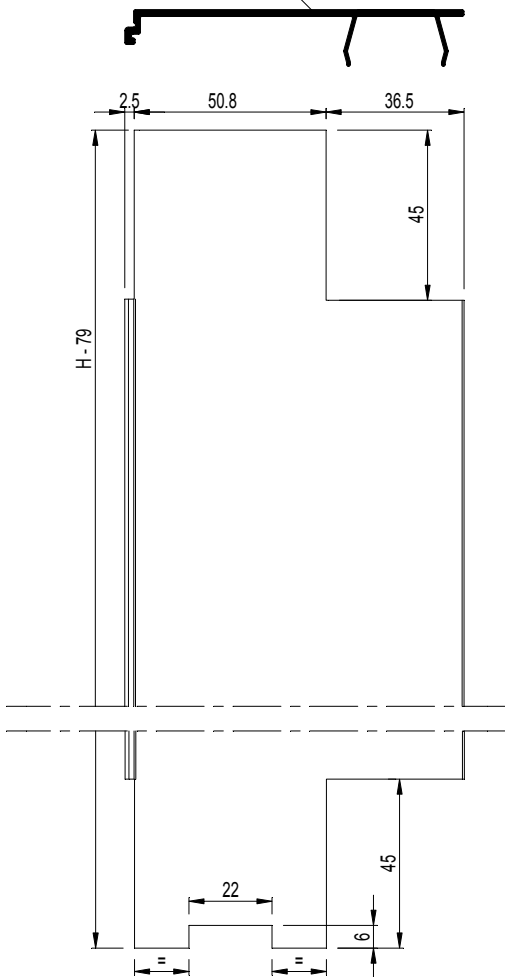

(\*) ENKEL VOOR MANUELE CONFIGURATIE  
UNIQUEMENT POUR CONFIGURATION MANUELE  
ONLY FOR MANUAL CONFIGURATION  
NUR FUER MANUELE KONFIGURATIE

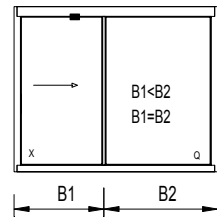

(\*\*) ENKEL VOOR MOTORISCHE CONFIGURATIE  
UNIQUEMENT POUR CONFIGURATION MOTEUR  
ONLY FOR MOTOR CONFIGURATION  
NUR FUER MOTOR KONFIGURATIE

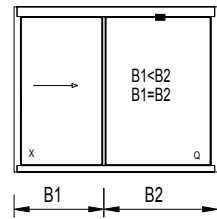

5

106.1395.XX

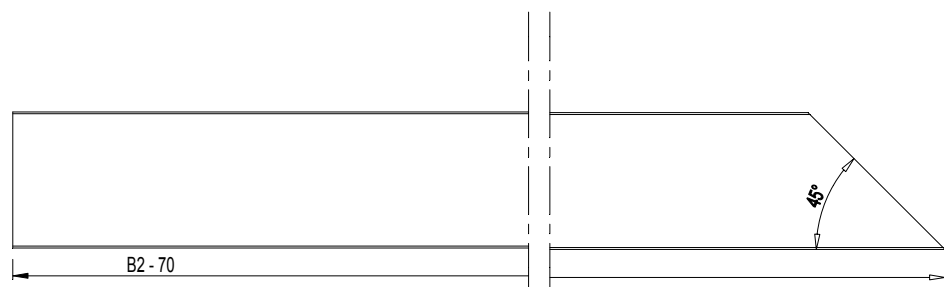

6

106.1395.XX

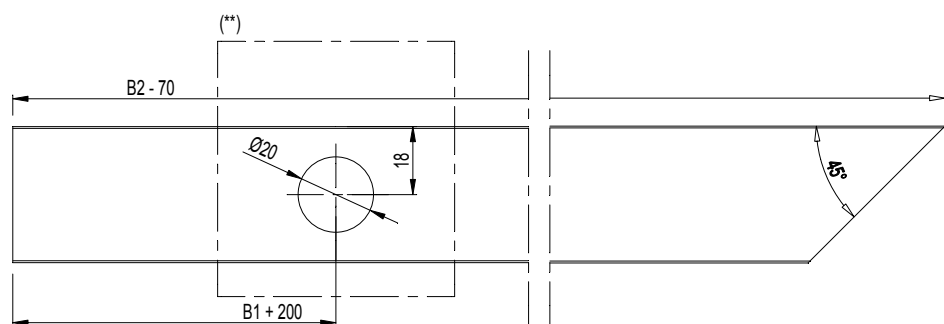

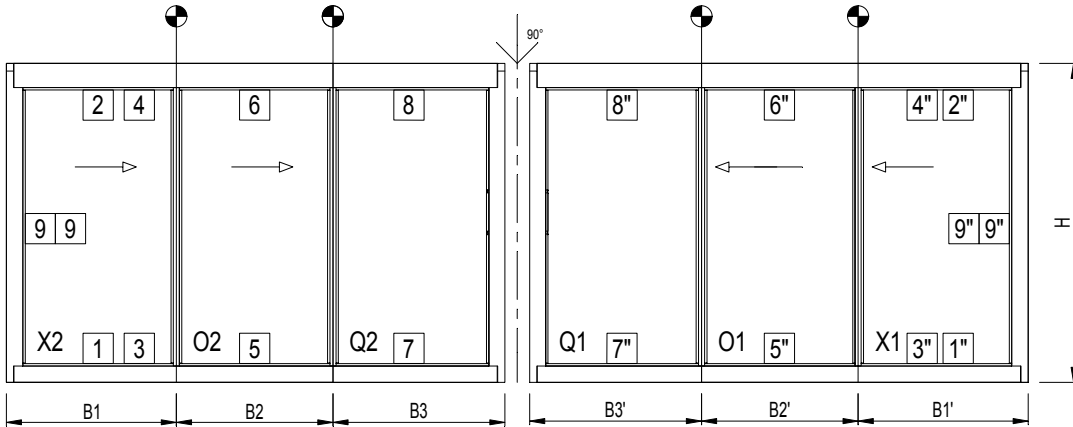

## Outside Corner

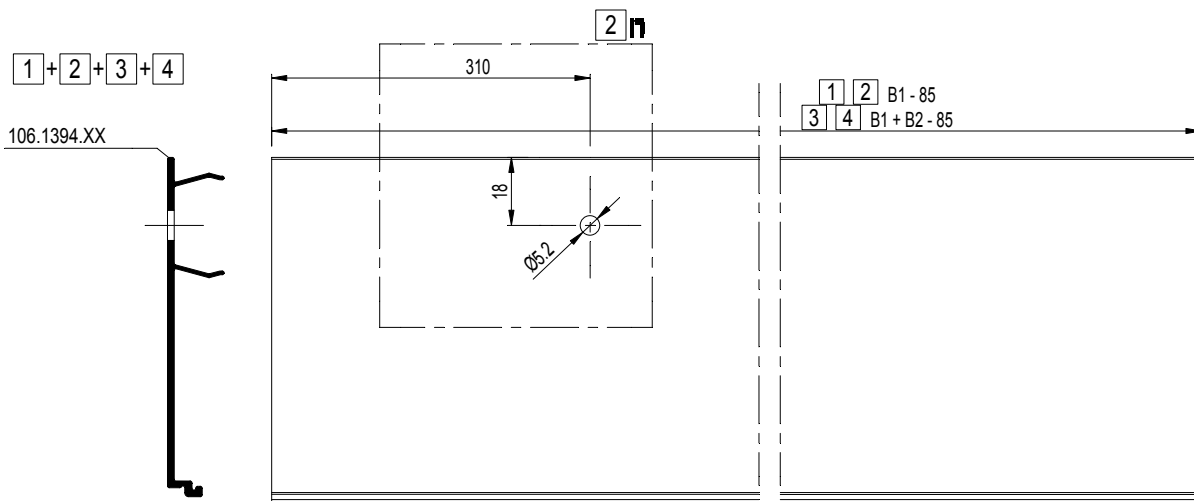
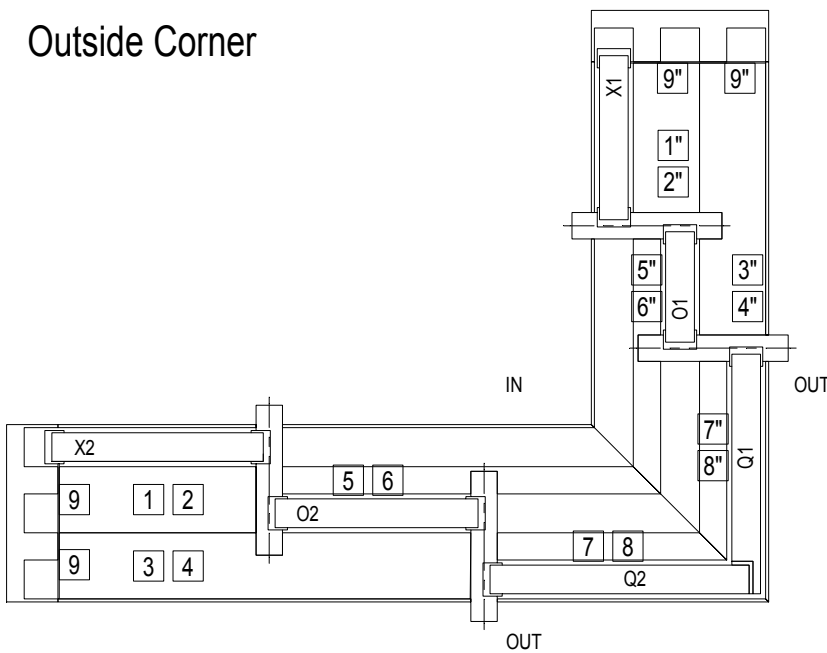

3 4 5 6 8 ARE MIRROR VERSION OF PROFILES 3 4 5 6 8

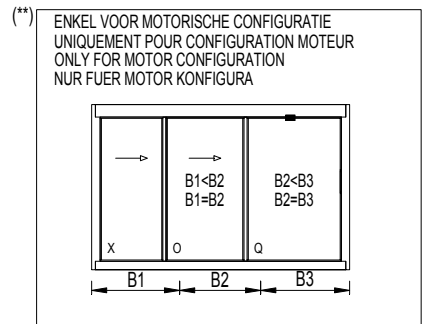
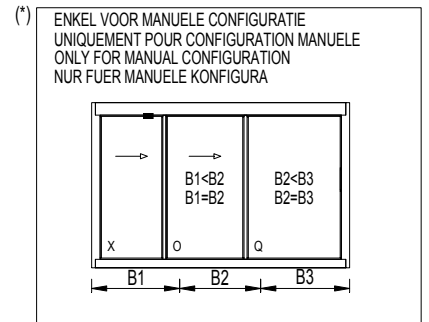
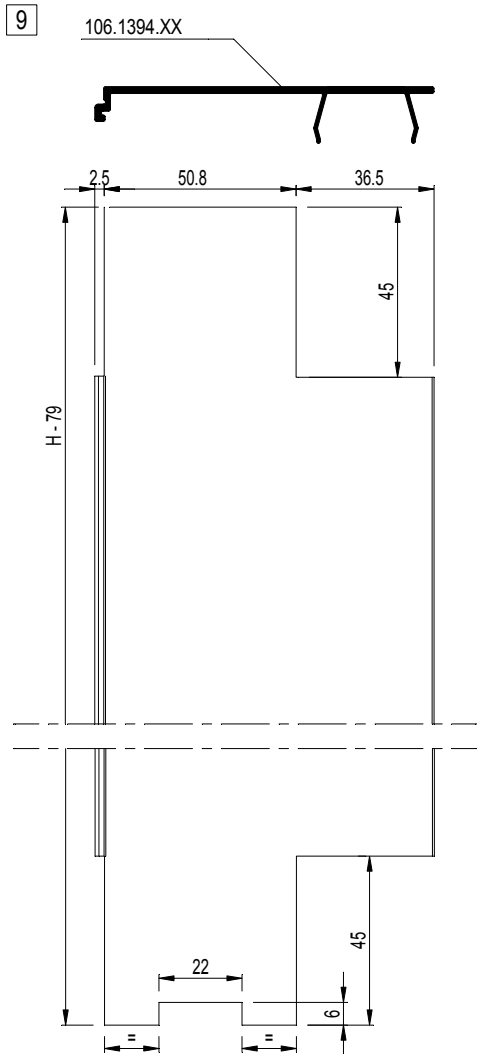

5 + 7

106.1395.XX

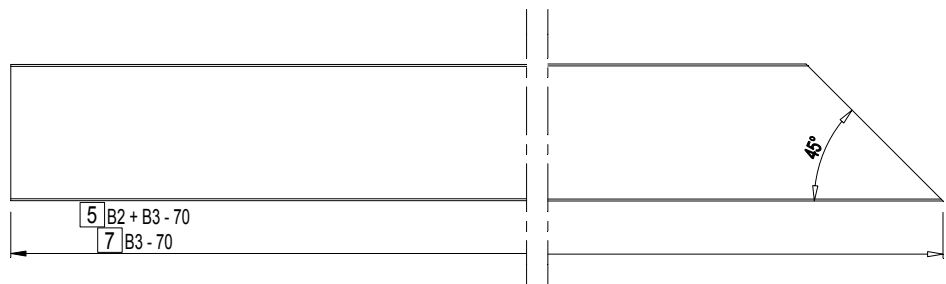

6 + 8

106.1395.XX

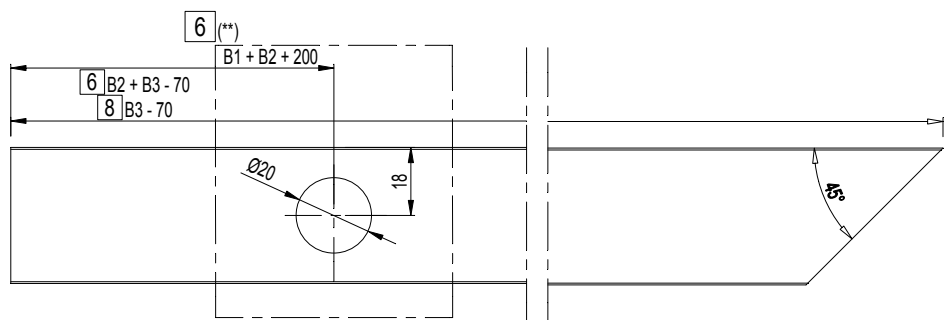

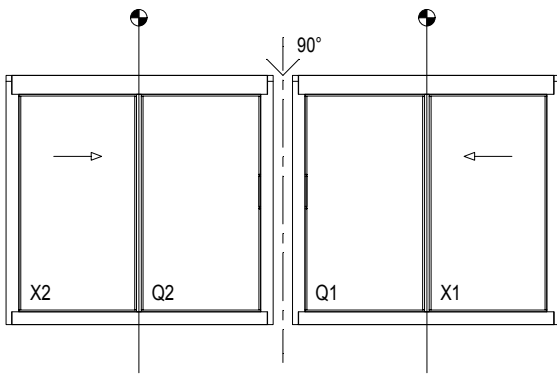

Inside Corner

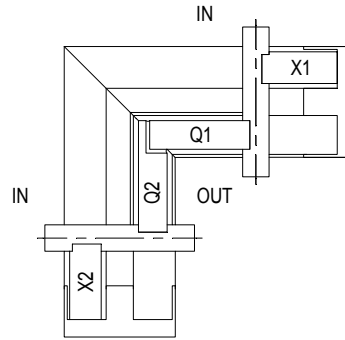

095.C300.00

of / ou / or / oder

095.N000.00

of / ou / or / oder

097.0103.00 (\*)

View X

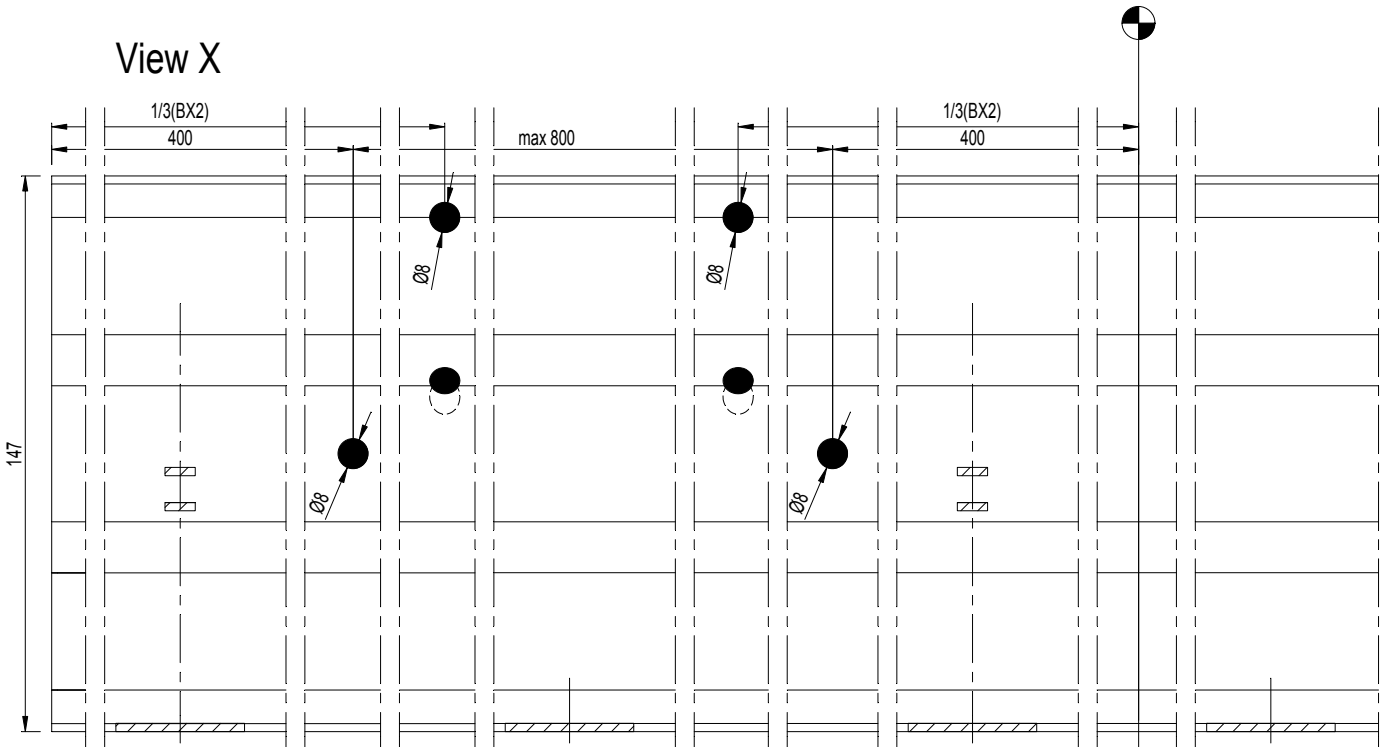

View Y

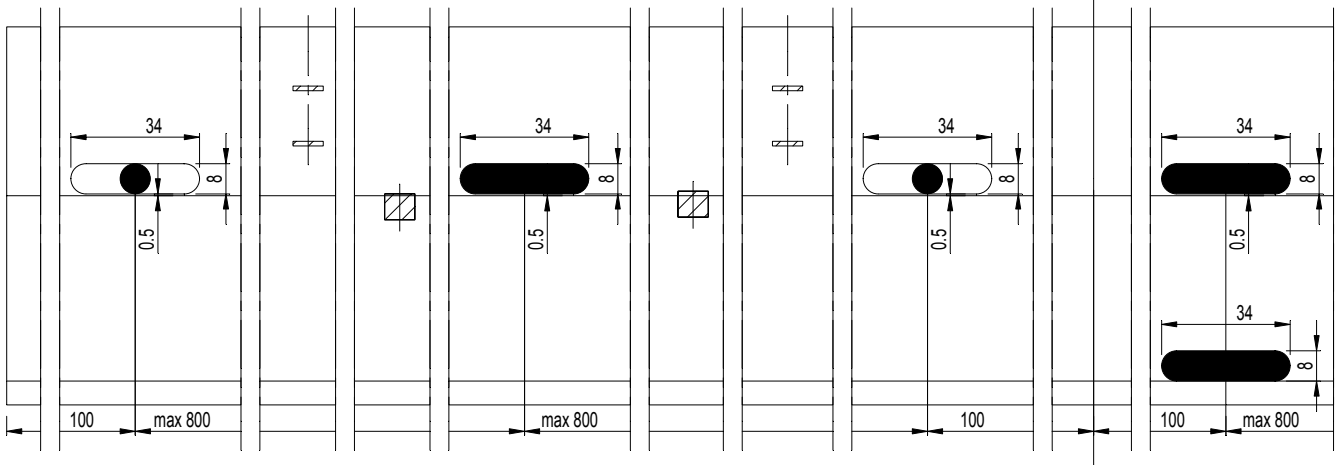

D2000487

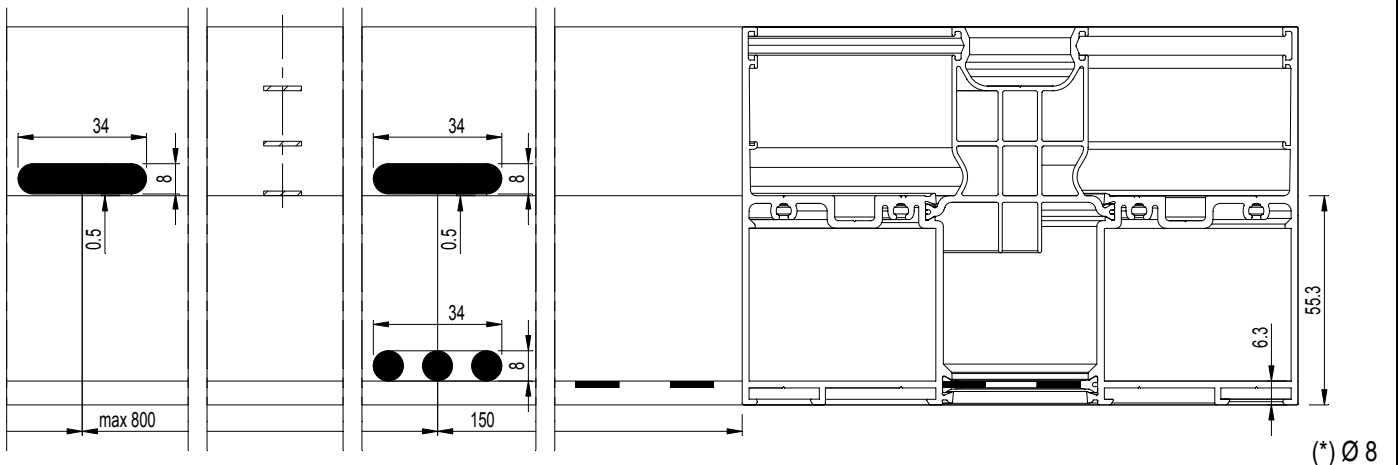
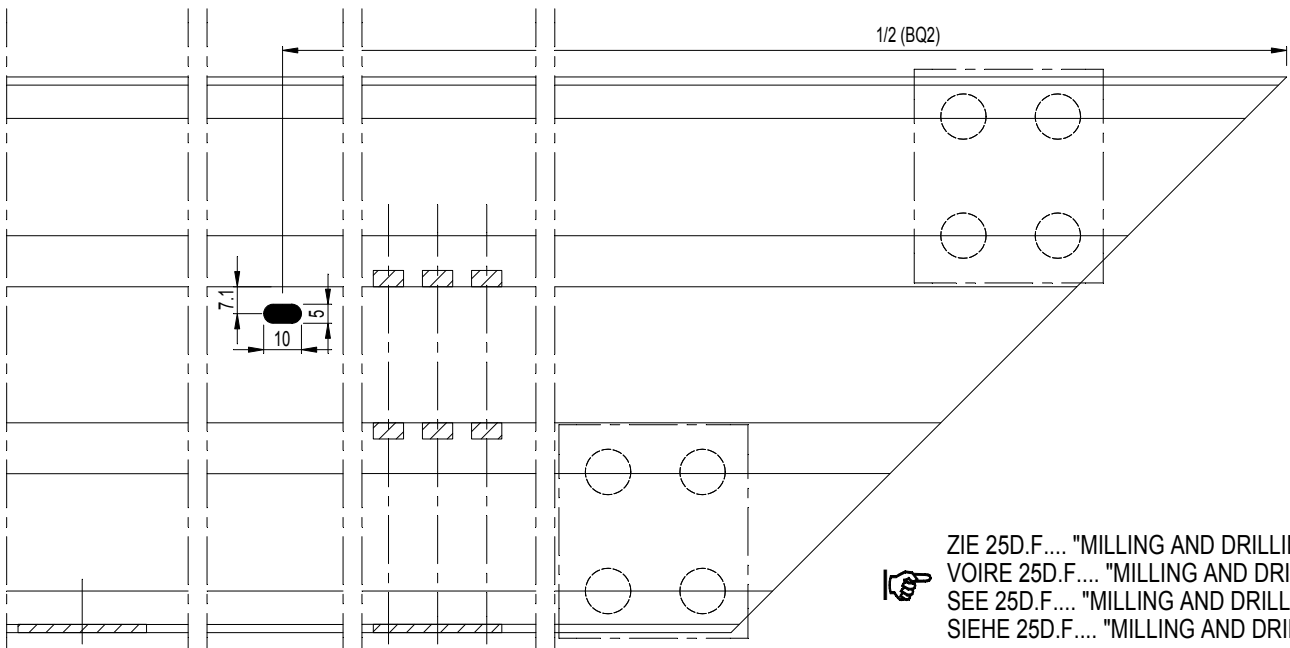
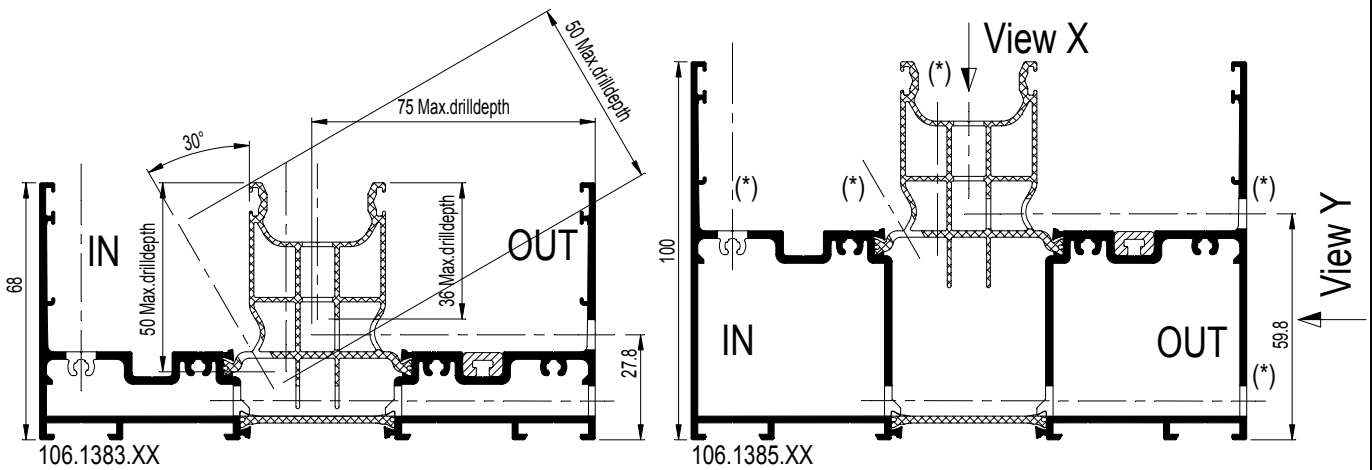

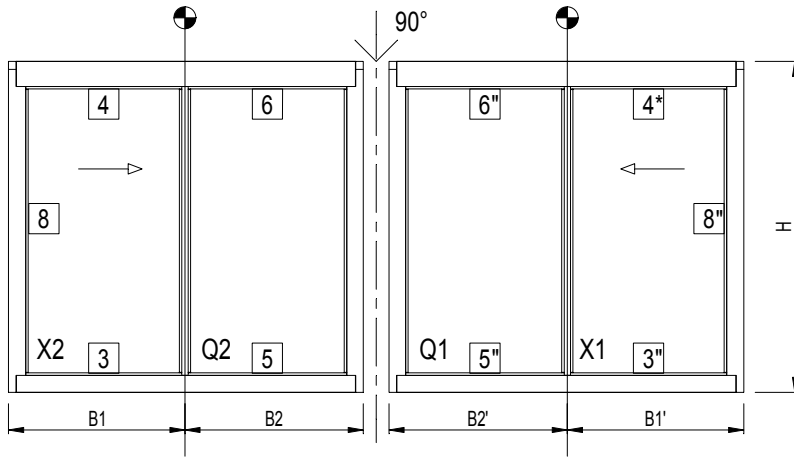

### Inside Corner

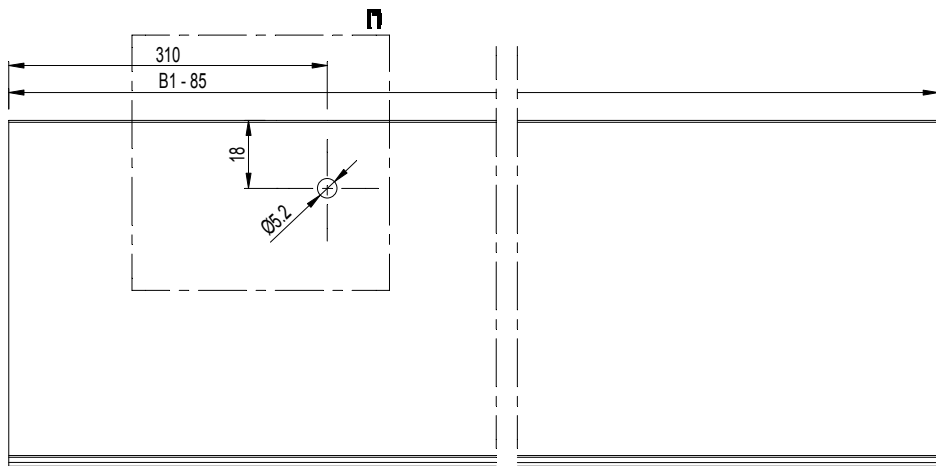
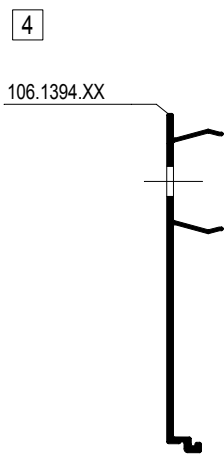
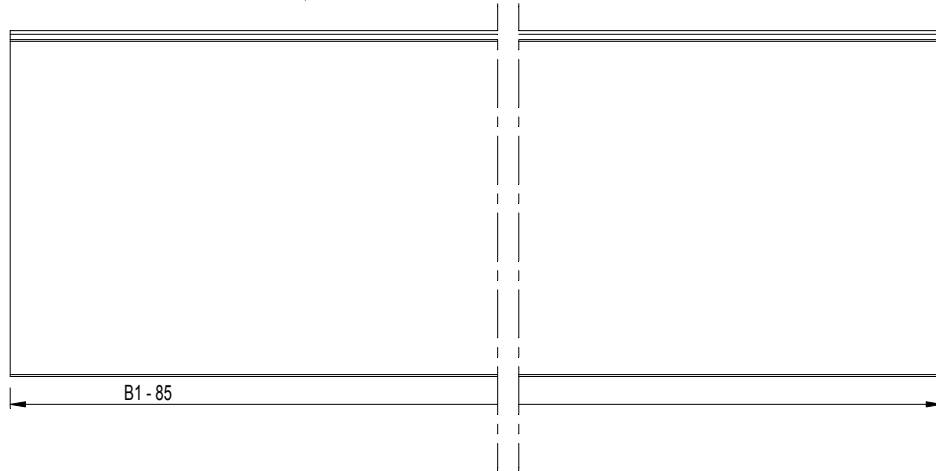
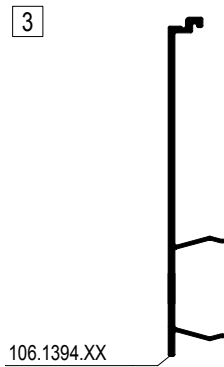
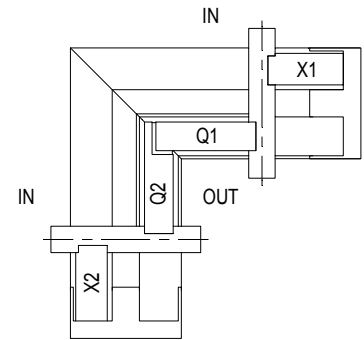

3 4 5 6 8 ARE MIRROR VERSION OF PROFILES 3 4 5 6 8

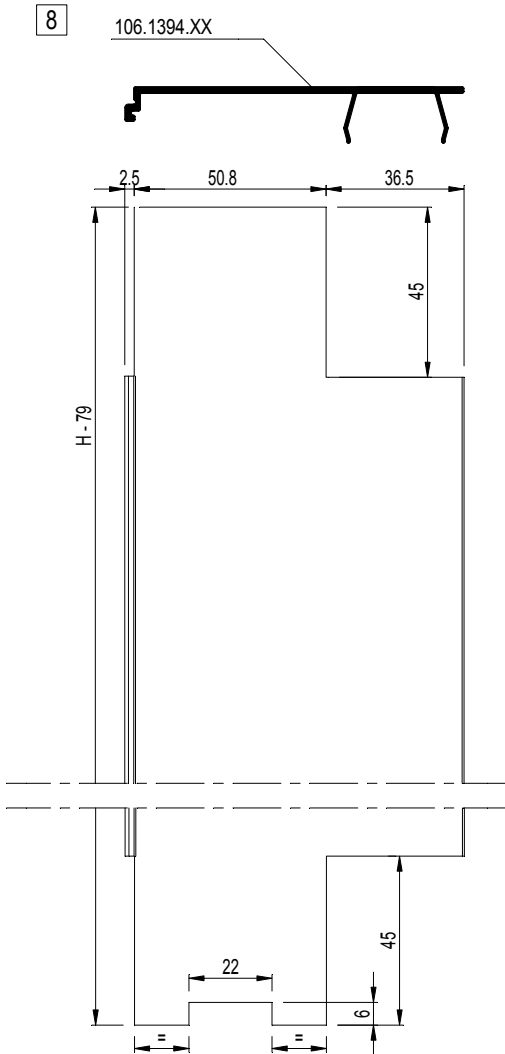

(\*) ENKEL VOOR MANUELE CONFIGURATIE  
 UNIQUEMENT POUR CONFIGURATION MANUELE  
 ONLY FOR MANUAL CONFIGURATION  
 NUR FUER MANUELE KONFIGURATIE

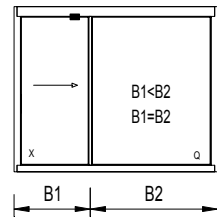

(\*\*) ENKEL VOOR MOTORISCHE CONFIGURATIE  
 UNIQUEMENT POUR CONFIGURATION MOTEUR  
 ONLY FOR MOTOR CONFIGURATION  
 NUR FUER MOTOR KONFIGURATIE

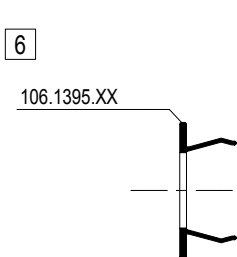
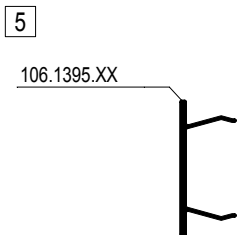
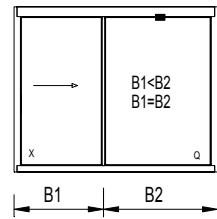

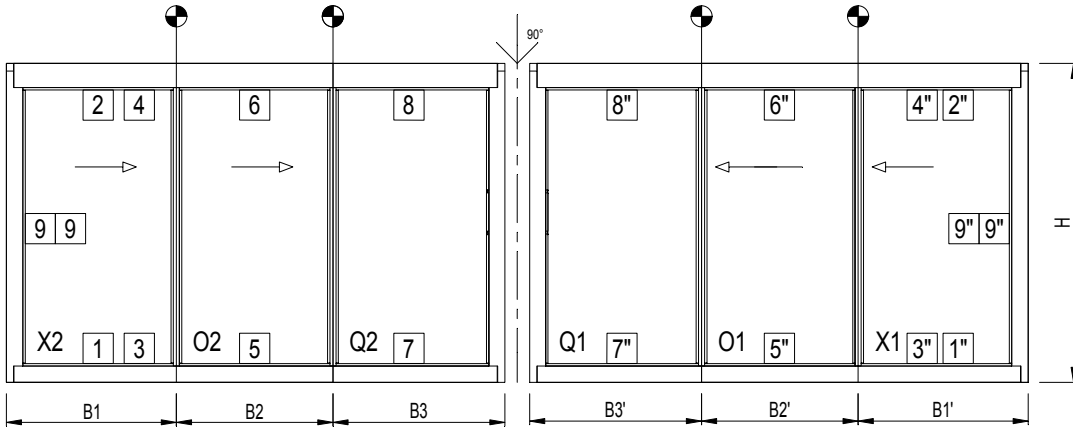

## Inside Corner

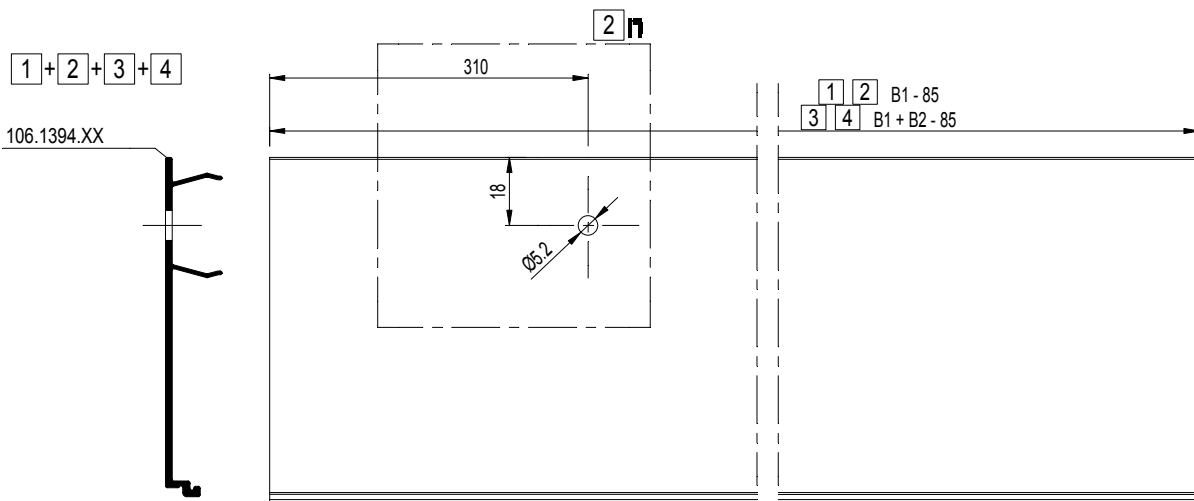
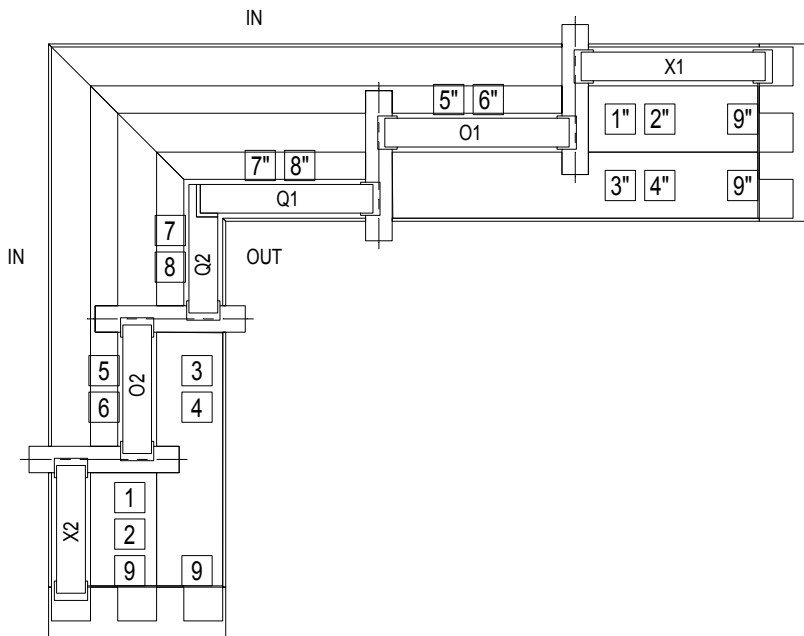

3 4 5 6 8 ARE MIRROR VERSION OF PROFILES 3 4 5 6 8



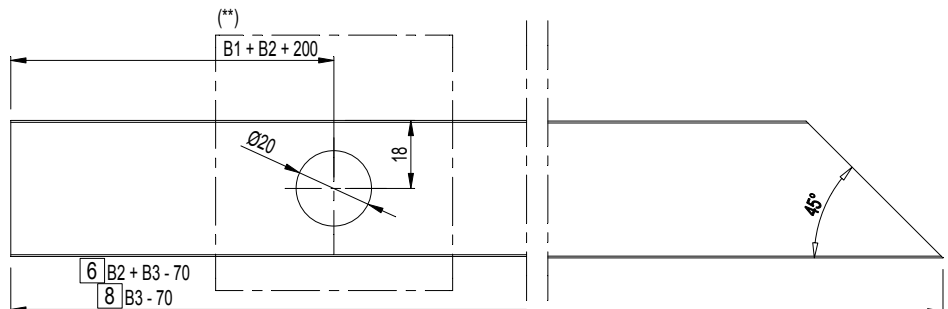
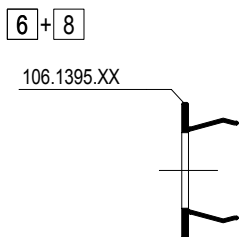
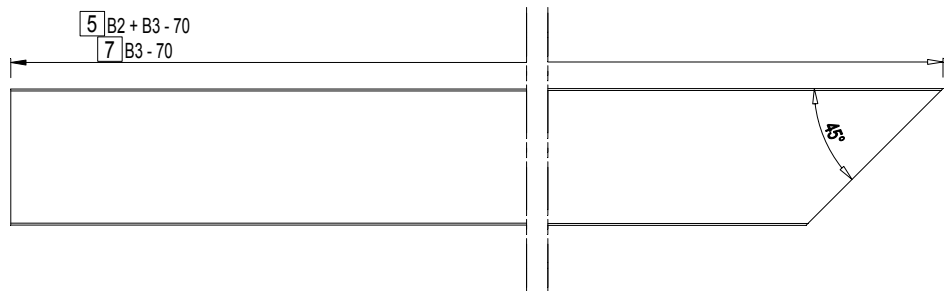
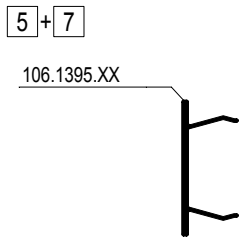
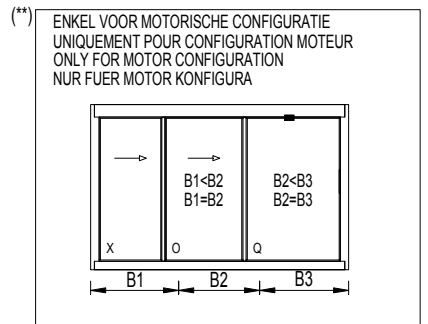
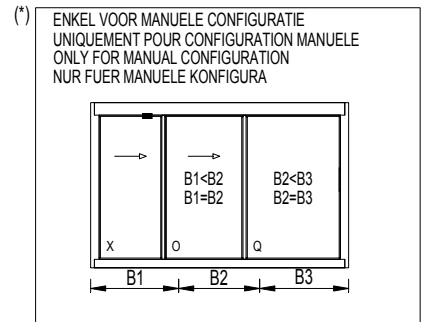
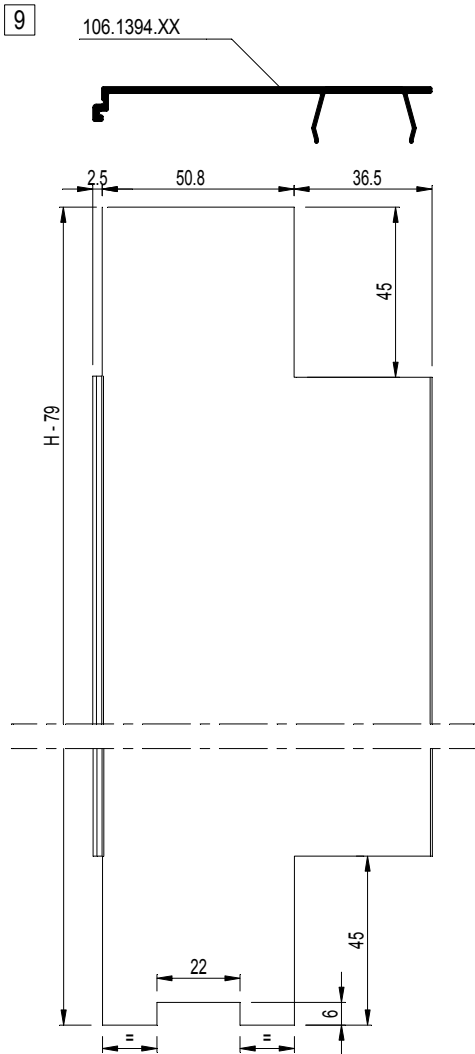

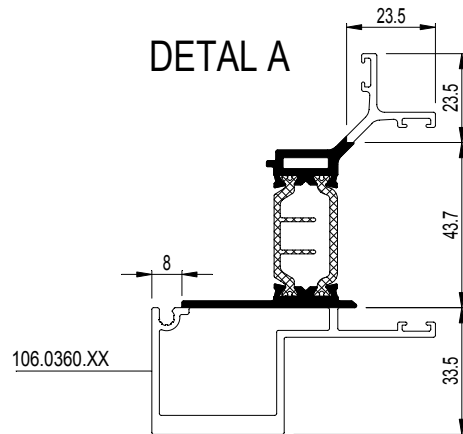
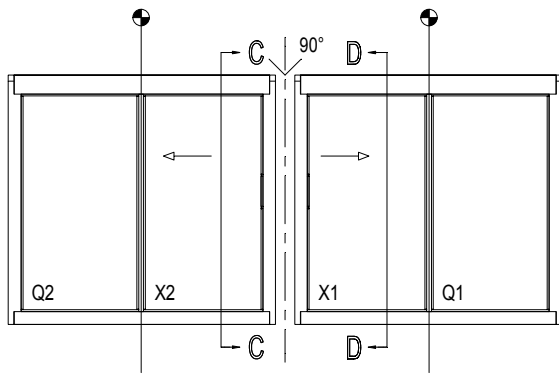

C - C

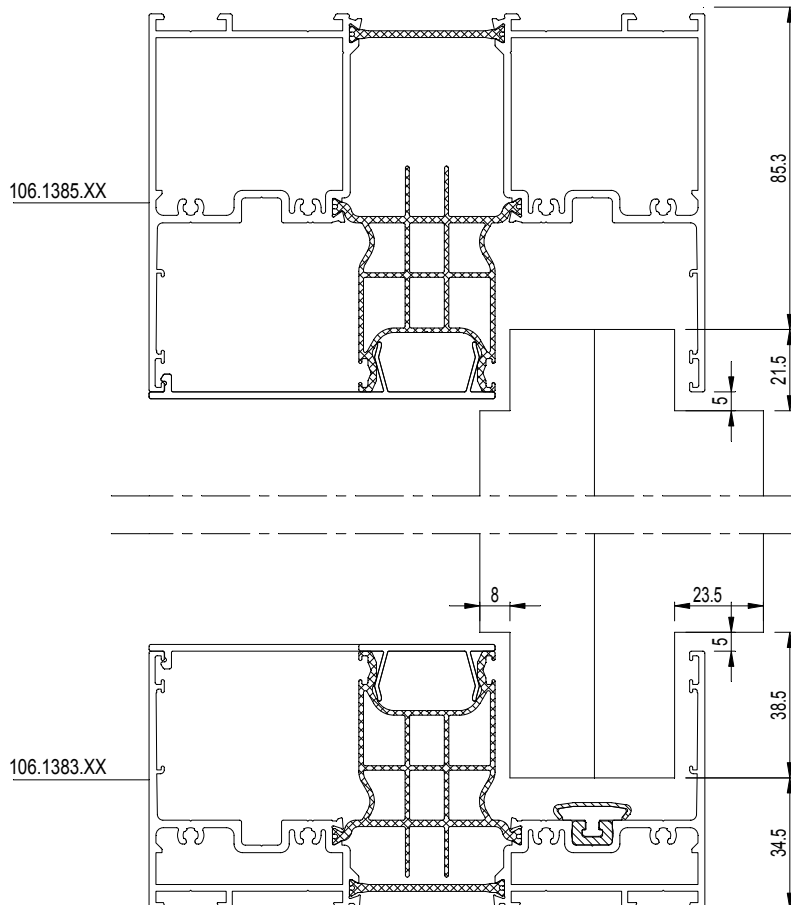

## Inside Corner

DEATAL A

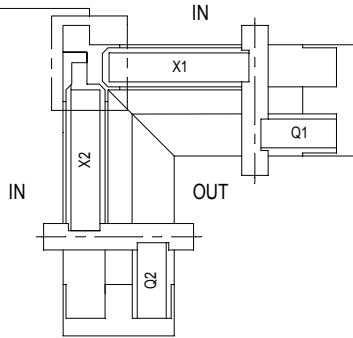

## Outside Corner

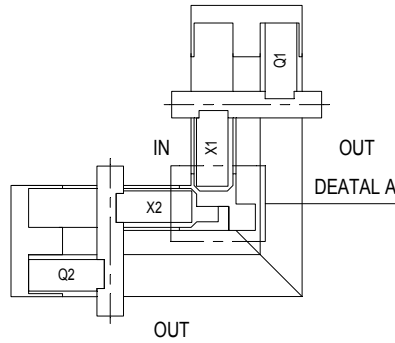

## DETAL A

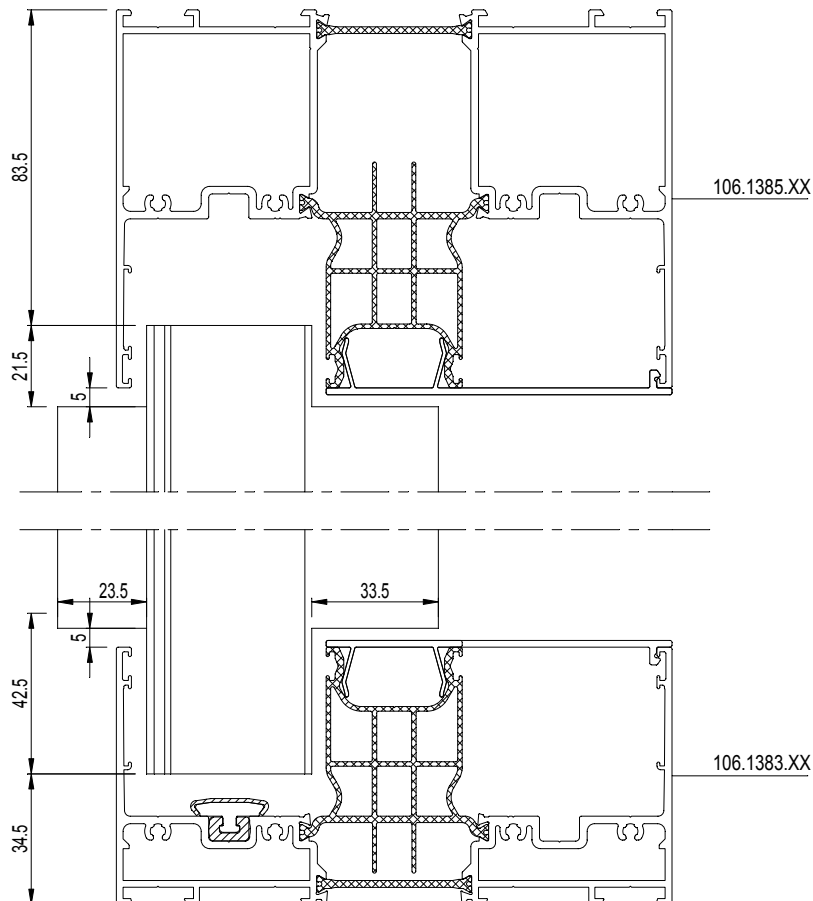
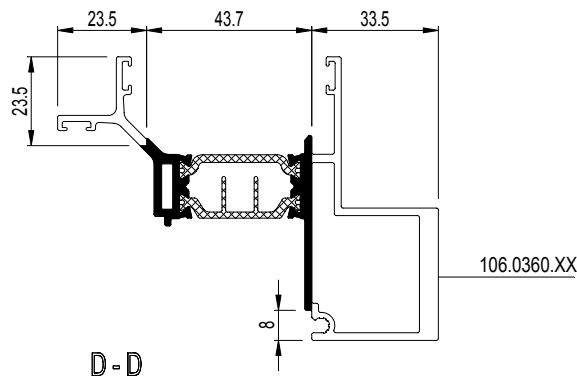

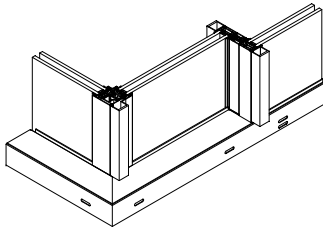

BOTTOM VIEW

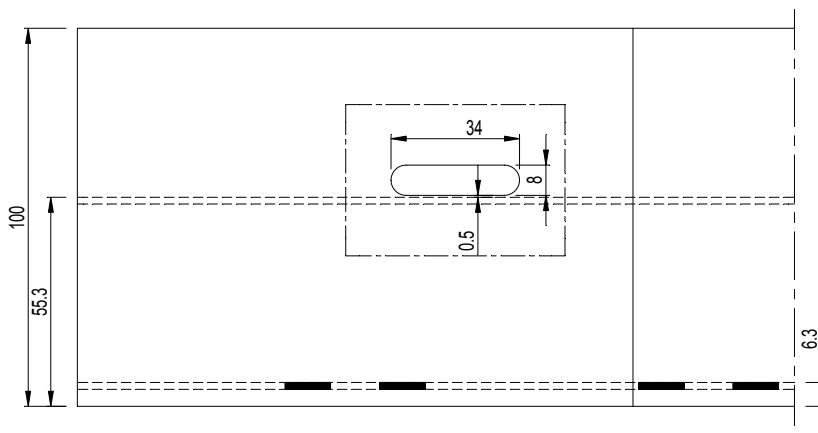
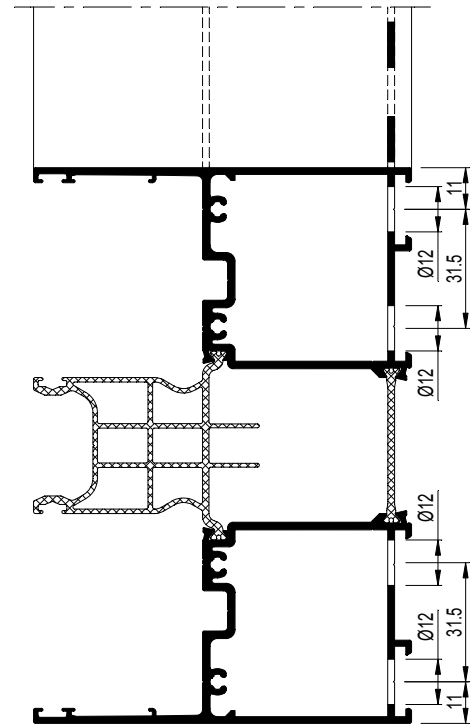
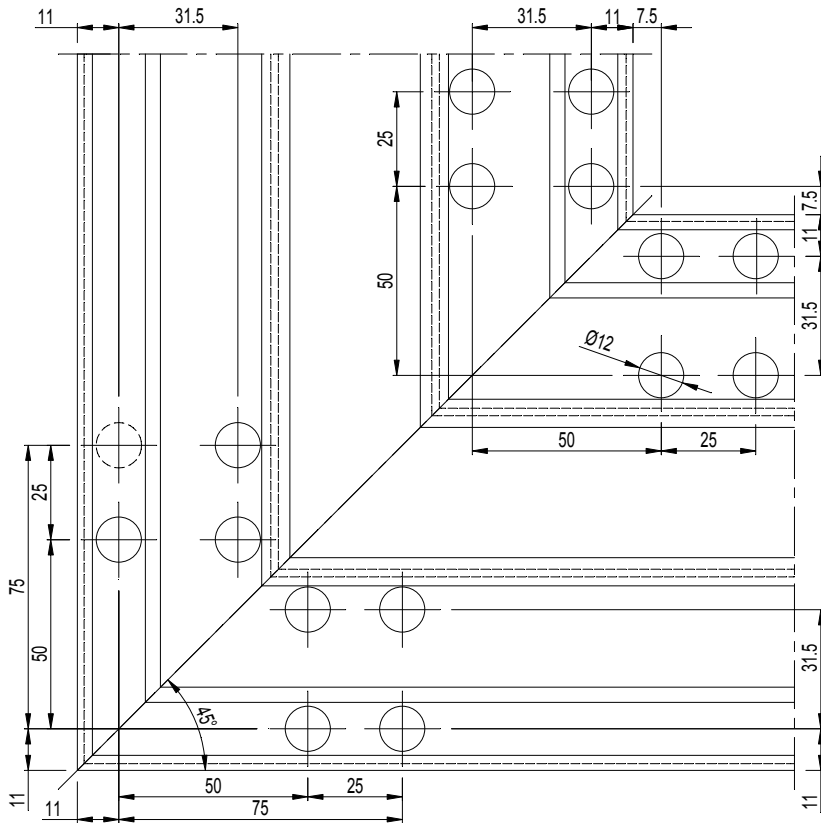

ZIE 25D.F.... "DRAINAGE"  
 VOIRE 25D.F.... "DRAINAGE"  
 SEE 25D.F.... "DRAINAGE"  
 SIEHE 25D.F.... "DRAINAGE"



097.0133.00

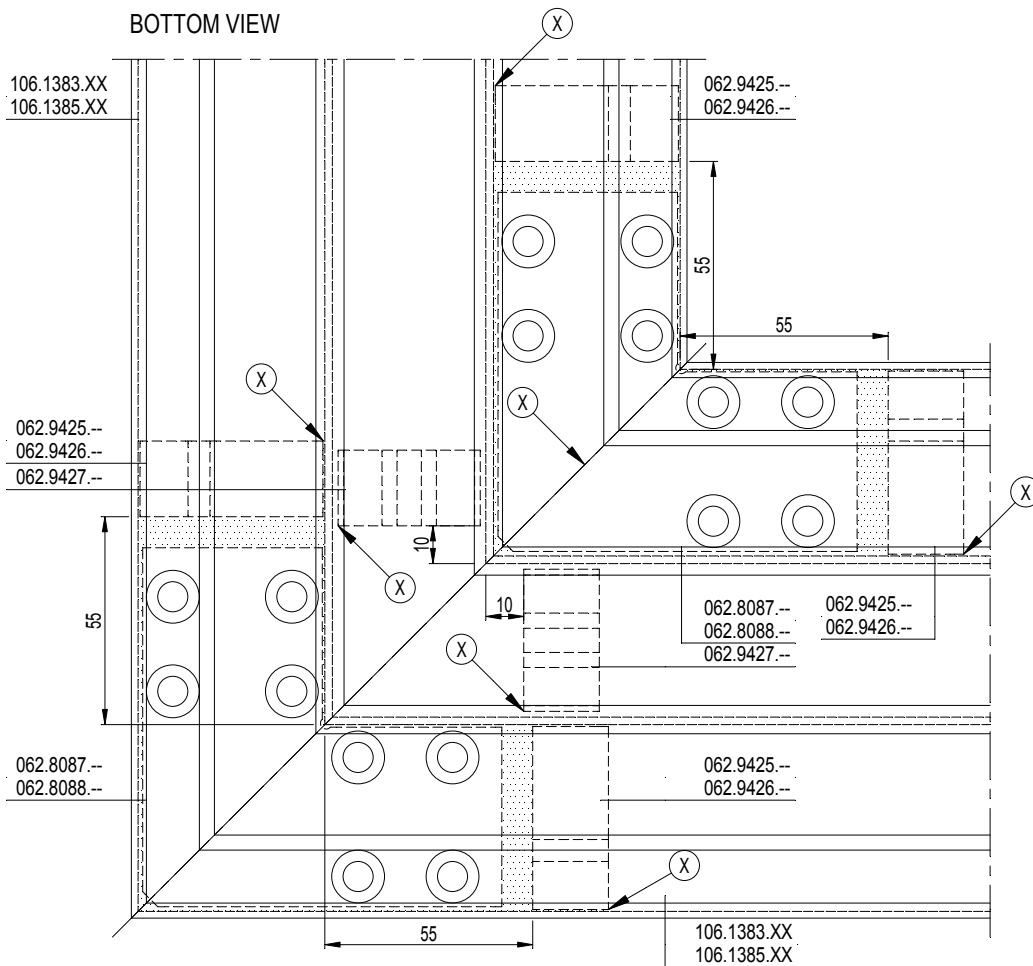
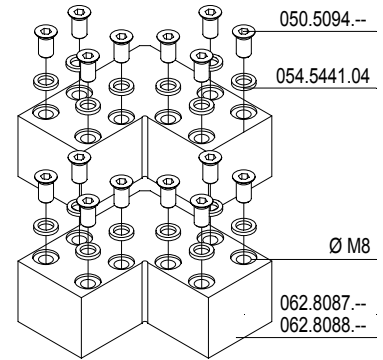
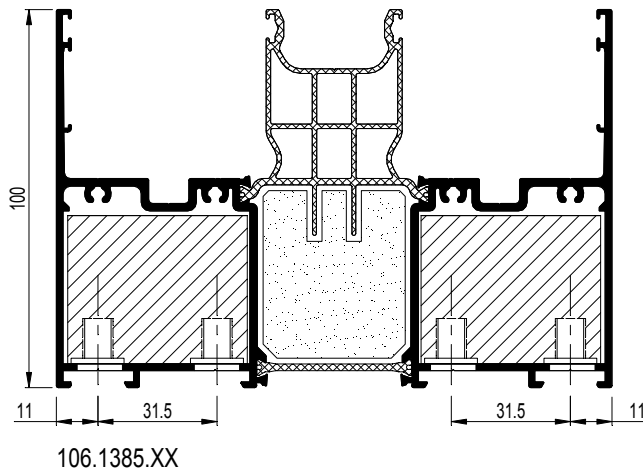

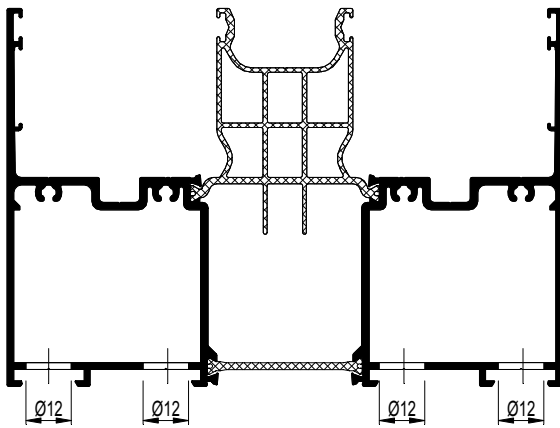
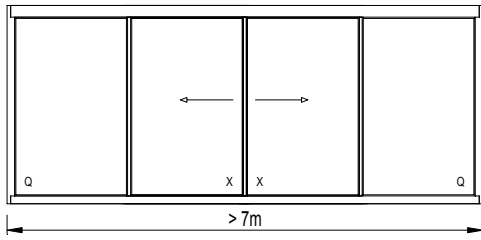

BOTTOM VIEW

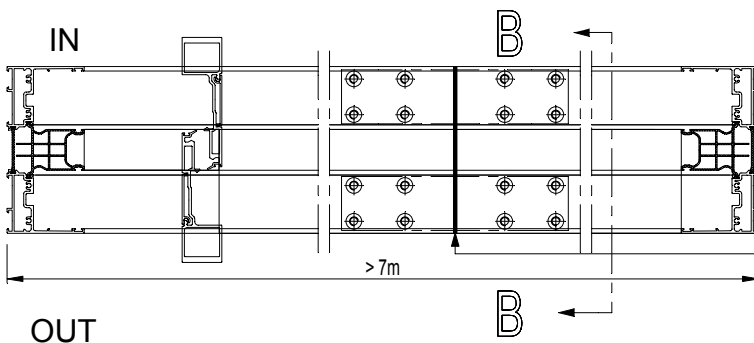
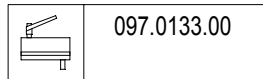
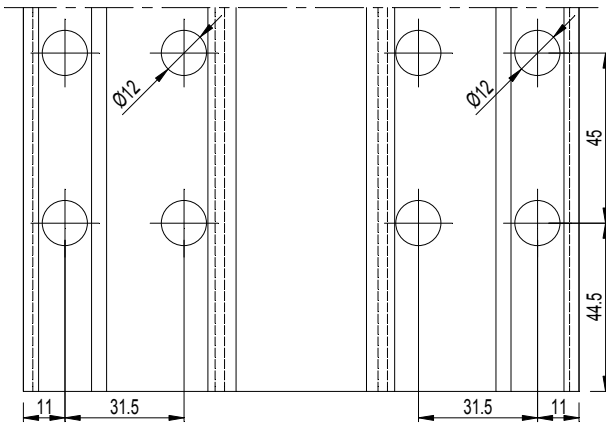

KOPPELING  
ACCOUPEMENT  
COUPLING  
KUPPLUNG

MONTAGEVOLGORDE  
L'ORDRE DE MONTAGE  
THE ORDER OF ASSEMBLY  
MONTAGEREIHENFOLGE

1	2	3	.
---	---	---	---

DICHTINGSMIDDEL  
MATIERE D'ETANCHEITE  
SEALING AGENT  
ABDICHTUNG

084.9063.XX

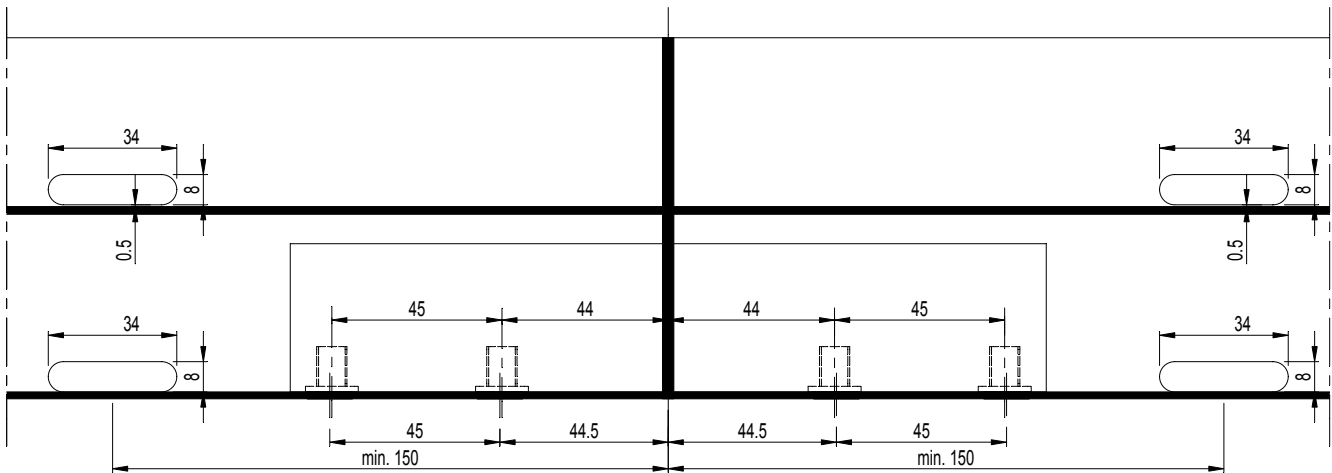
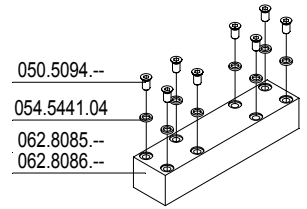
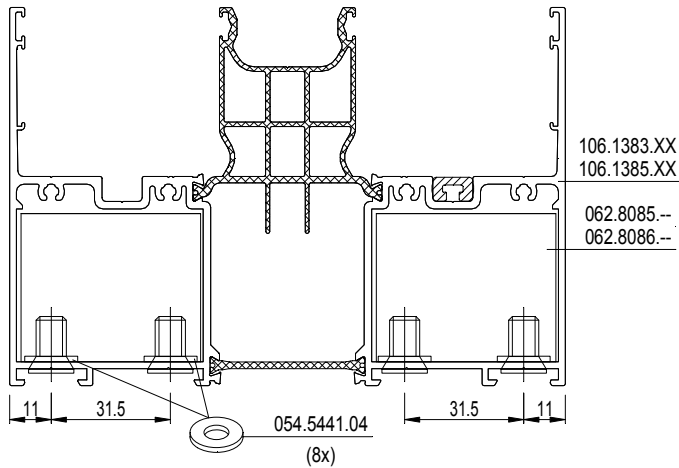

PRINCIPETEKENING  
DESSIN DE PRINCIPE  
SCHEMATIC DRAWING  
GRUNDSATZZEICHNUNG

B - B

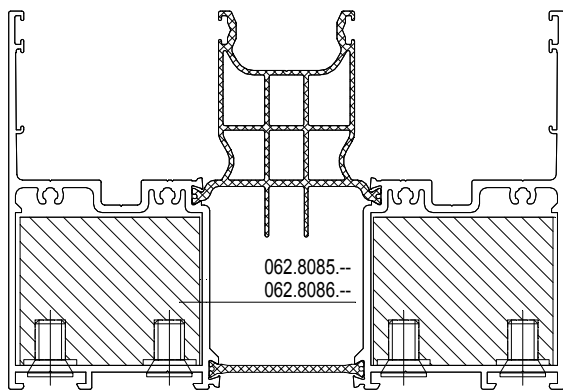

BIJ KOPPELING, GEBRUIK WATERDICHTE FOLIE  
EN CAS DE RACCORDEMENT, EMPLOYEZ DU FEUIL ETANCHE  
WHEN CONNECTING, PLEASE APPLY WATERTIGHT FOIL  
BEI KOPPELUNG, WENDEN SIE EINE WASSERDICHTE FOLIE AN

ZIE ARCHITECTENKATALOG  
VOIR ARCHITECTE CATALOGUE  
SEE ARCHITECT CATALOGUE  
SEHEN ARCHITEKT KATALOG

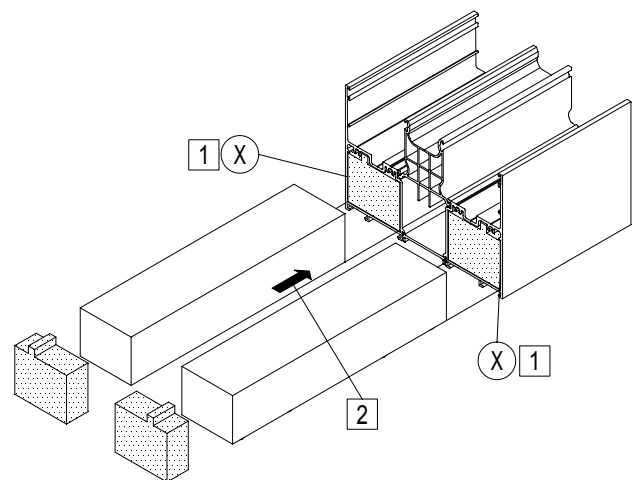

1

AFDICHTEN OP DE ZAAGSNEDEN EN IN DE PROFIELKAMER  
ETACHEMENT DES COUPES ET DANS LA CHAMBRE DU PROFILE  
SEALING ON THE SAW CUTS AND IN THE PROFILE CHAMBER  
DIE SCHNITTFLACHEN UND IN DEN PROFILKAMMERN, MIT EINER NEUTRALEN,  
ELASTISCHEN DICHTUNGSMASSE VERSEHEN

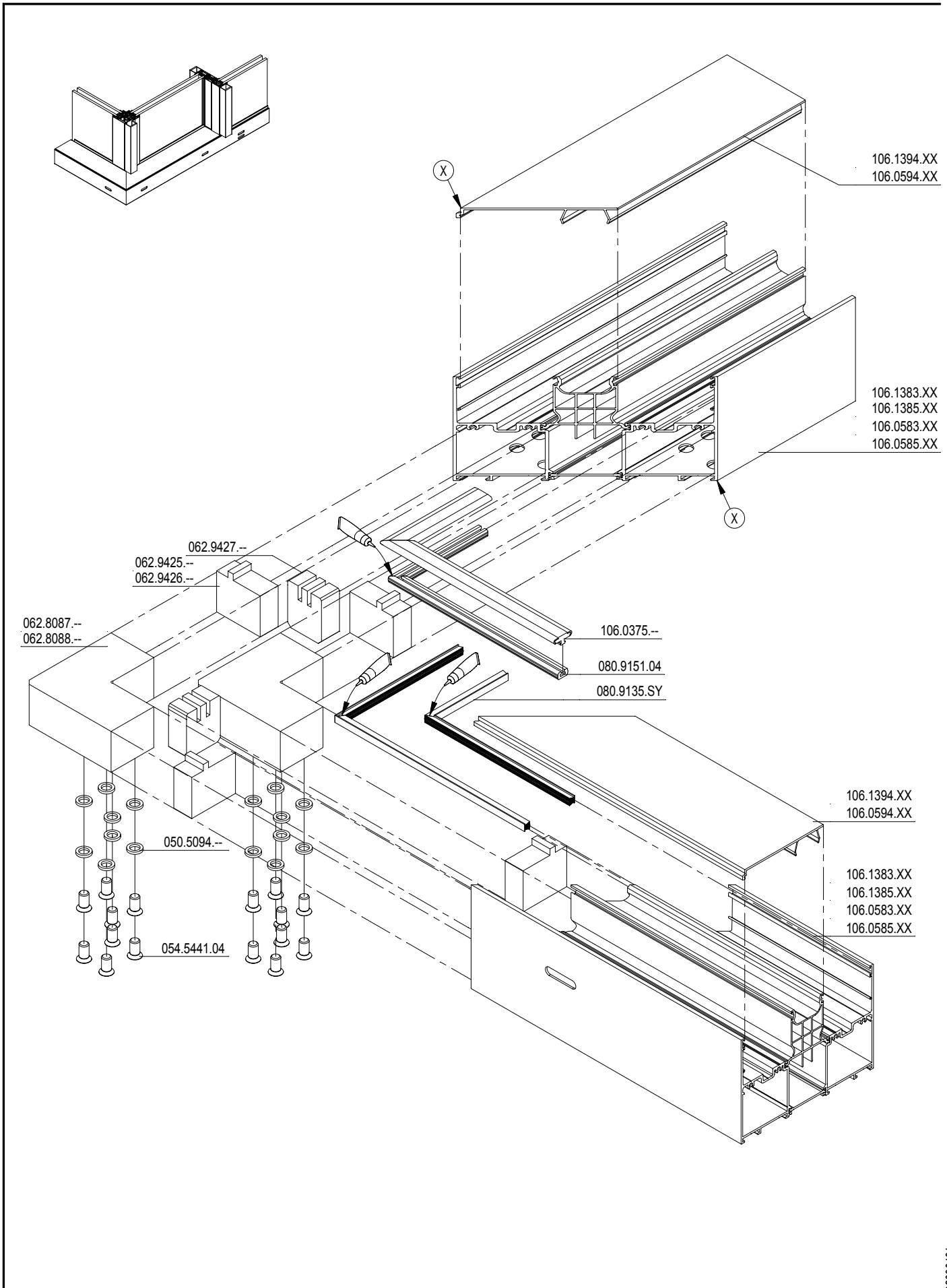



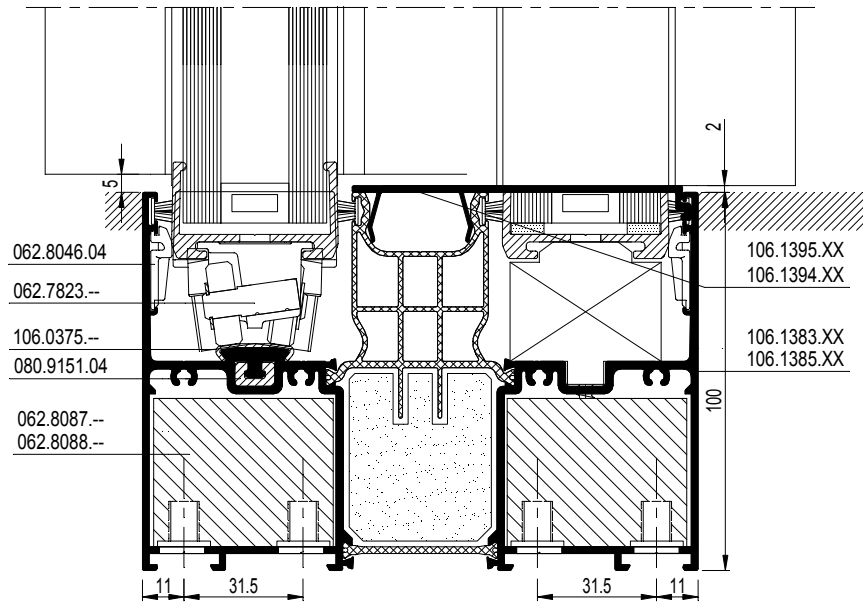

TOP VIEW

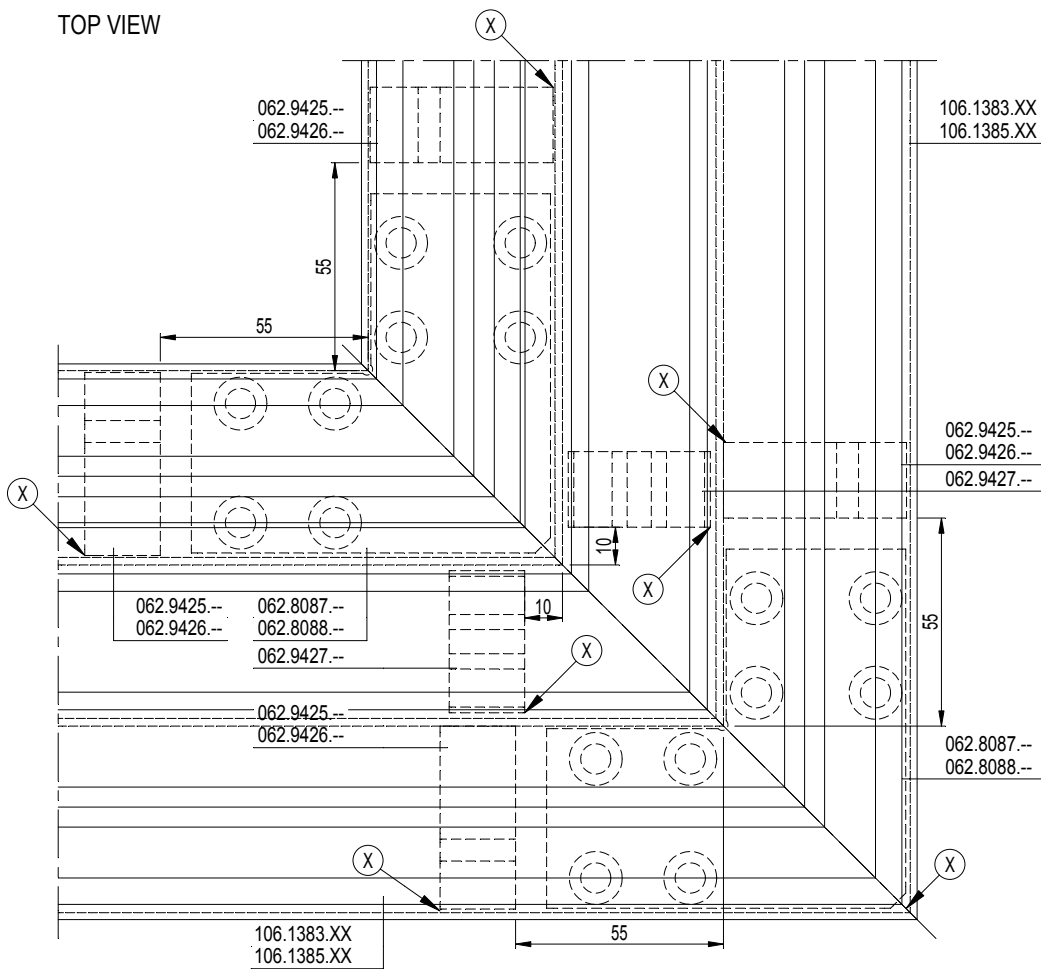

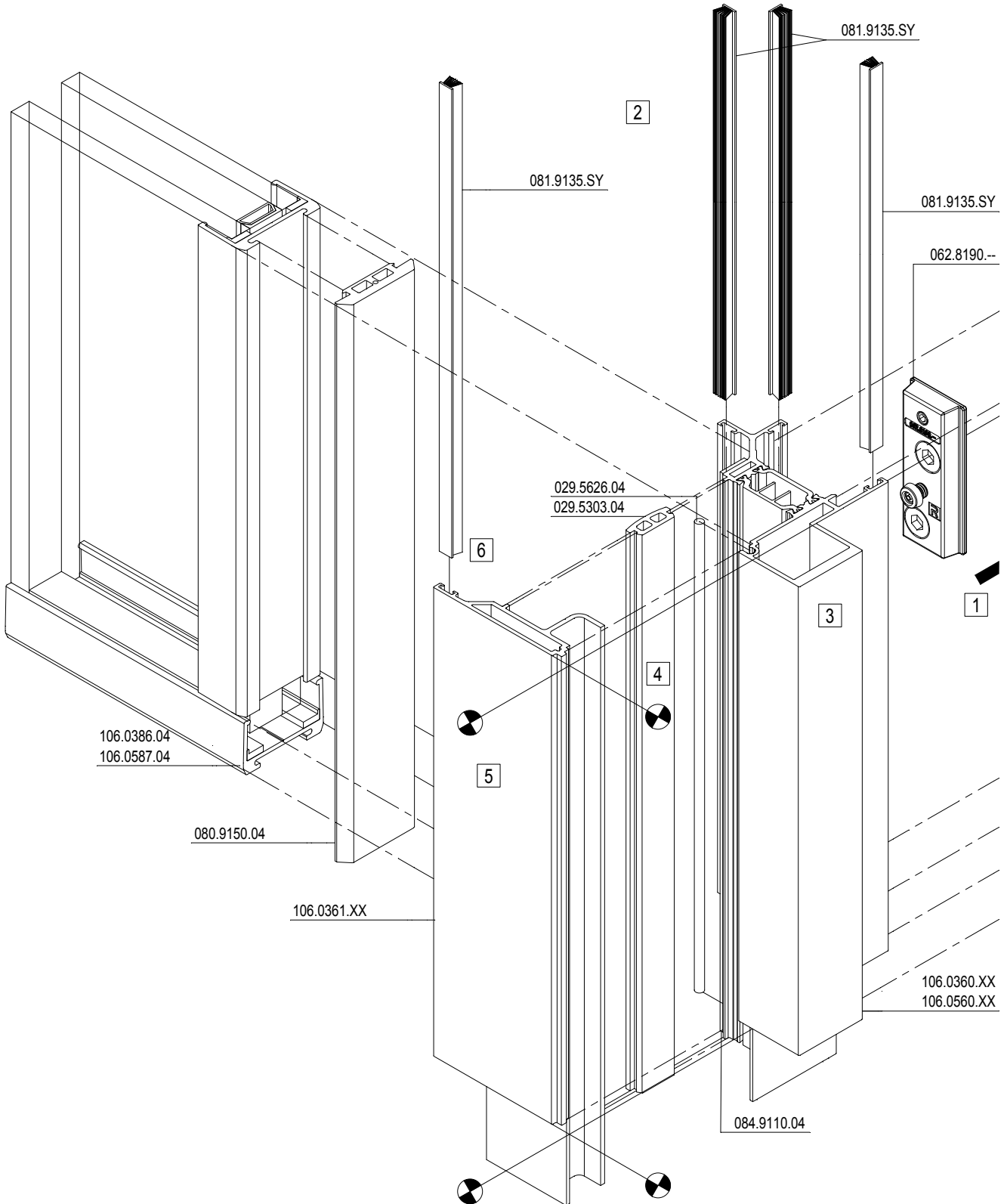

D0096425

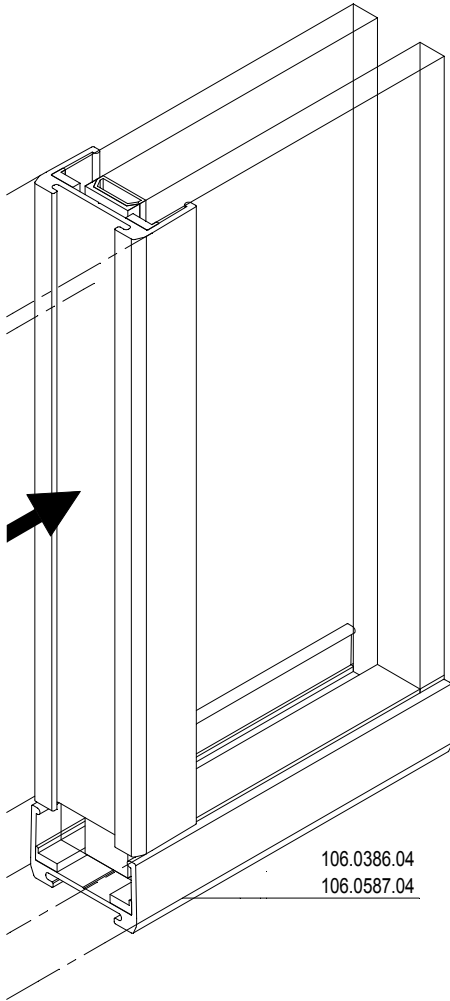
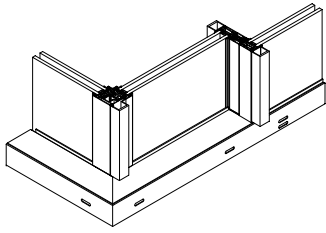

106.0386.04  
 106.0587.04

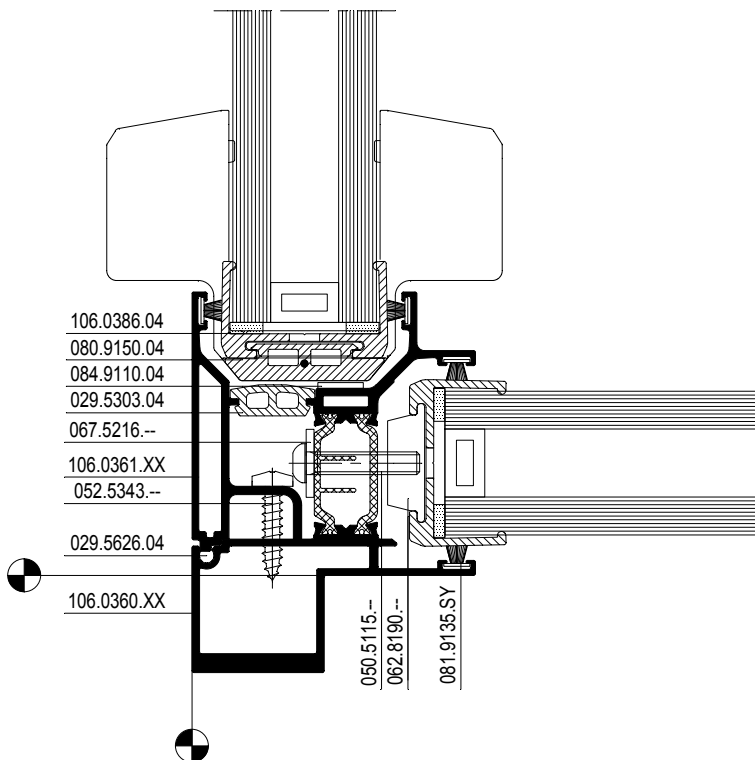

MONTAGEVOLGORDE	1	2	3	.
L'ORDRE DE MONTAGE				
THE ORDER OF ASSEMBLY				
MONTAGEREIHENFOLGE				

# HFP 147 HFP 179

STOPPER / MEENEMER  
ARRETEUR / ENTRAINEUR  
STOPPER / DRIVE PLATE  
STOPFEN / MITNEHMER

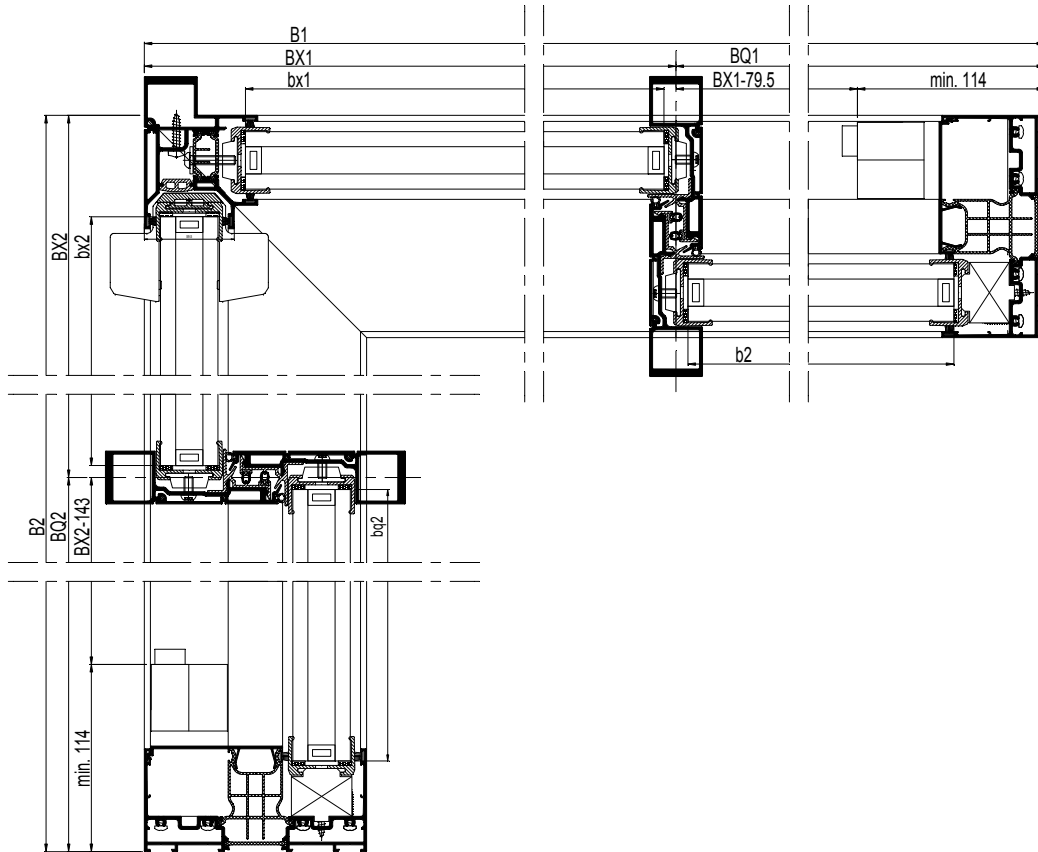

$$b(x) = b(q)$$

$$B(X) = B(Q) + 7$$

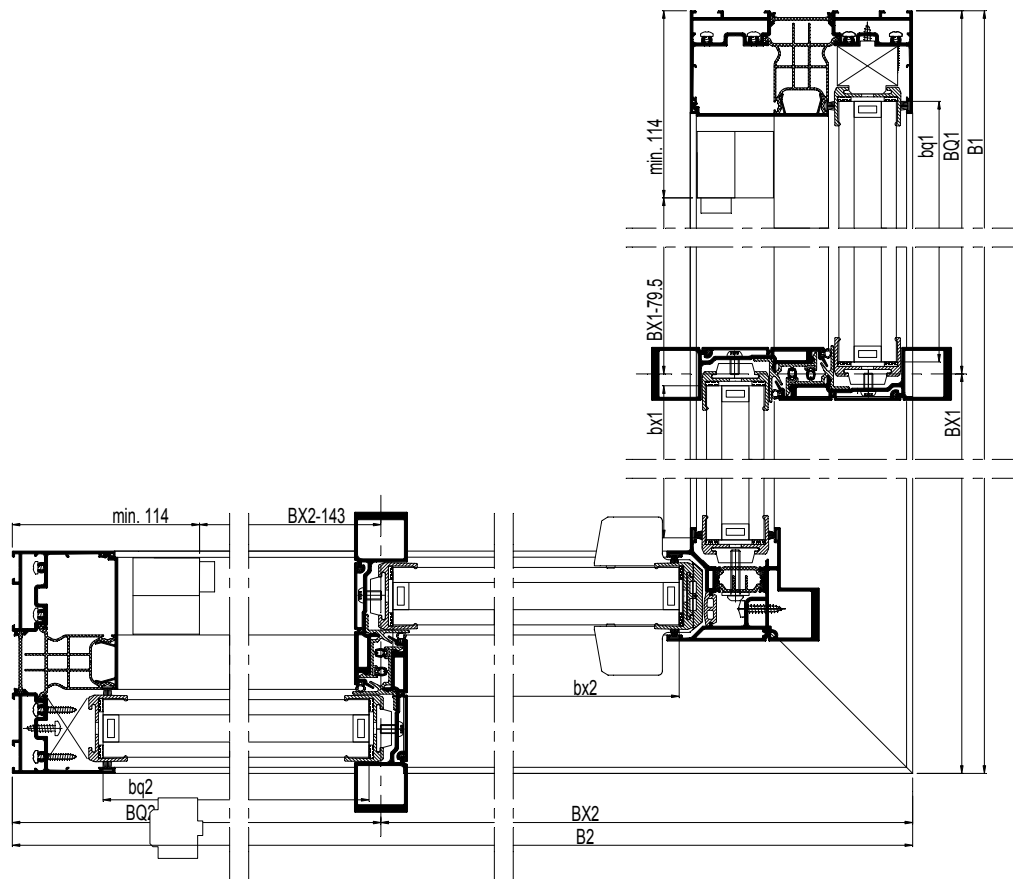

$$b(x) = b(q)$$

$$B(X) = B(Q) + 94$$

# HFP 147 HFP 179

STOPPER / MEENEMER  
ARRETEUR / ENTRAINEUR  
STOPPER / DRIVE PLATE  
STOPFEN / MITNEHMER

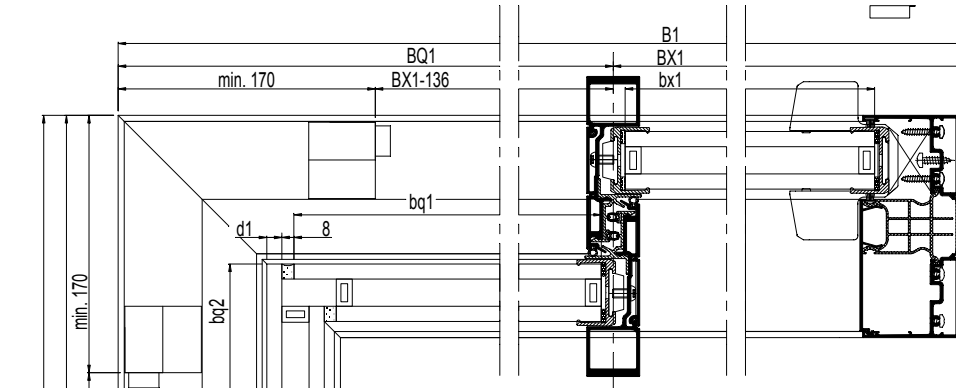

$$b(x) = b(q)$$

$$B(X) = B(Q) + 39$$

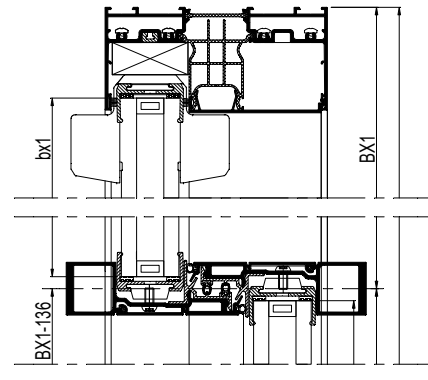
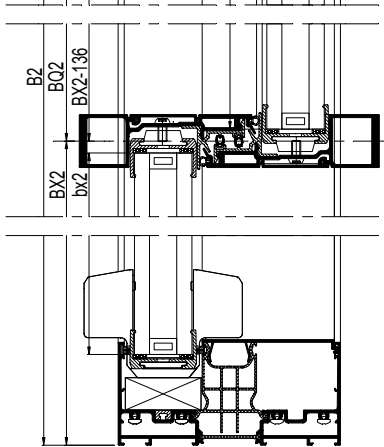

$$b(x) = b(q)$$

$$B(X) = B(Q) + 50$$

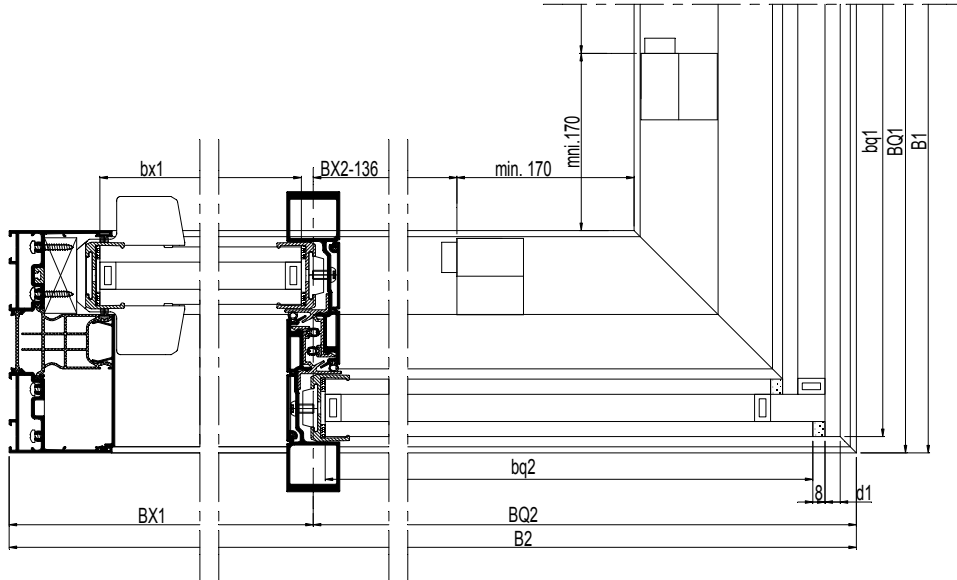

 STEP GLAS  
ETAPE DE VERRE  
STEP GLASS  
STEP GLASS

 ZIE 25D.E....  
VOIRE 25D.E....  
SEE 25D.E....  
SIEHE 25D.E....

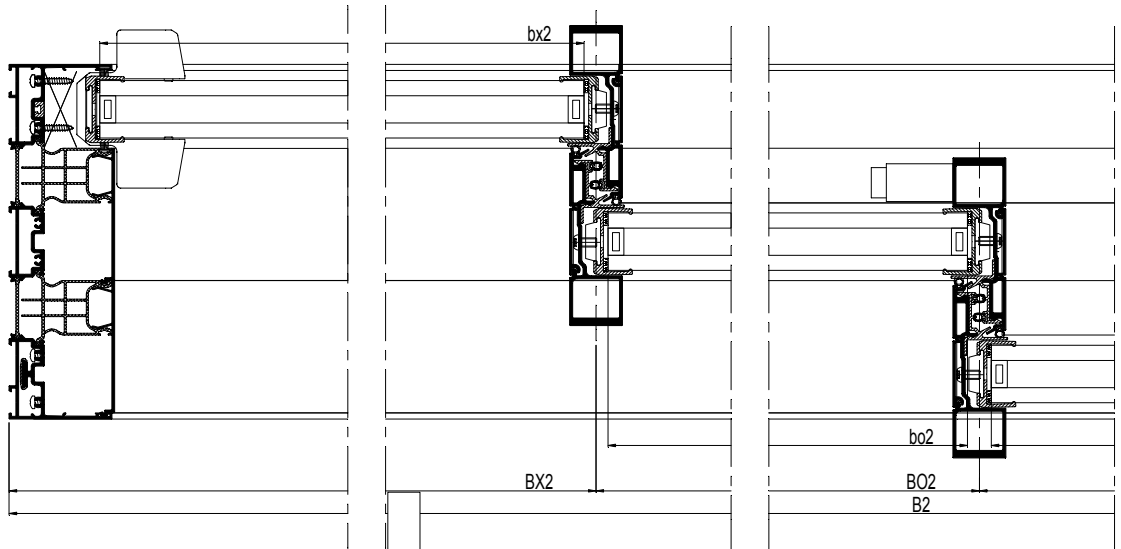

STEP GLAS  
ETAPE DE VERRE  
STEP GLASS  
STEP GLASS



ZIE 25D.E....  
VOIRE 25D.E....  
SEE 25D.E....  
SIEHE 25D.E....

# HFP 147 HFP 179

STOPPER / MEENEMER  
ARRETEUR / ENTRAINEUR  
STOPPER / DRIVE PLATE  
STOPFEN / MITNEHMER

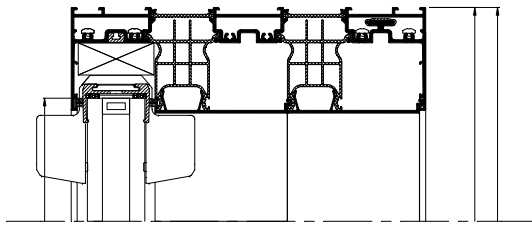

$$b(x) = b(o) = b(q)$$
$$B(X) = B(Q) + 50$$
$$B(O) = B(Q) - 2$$

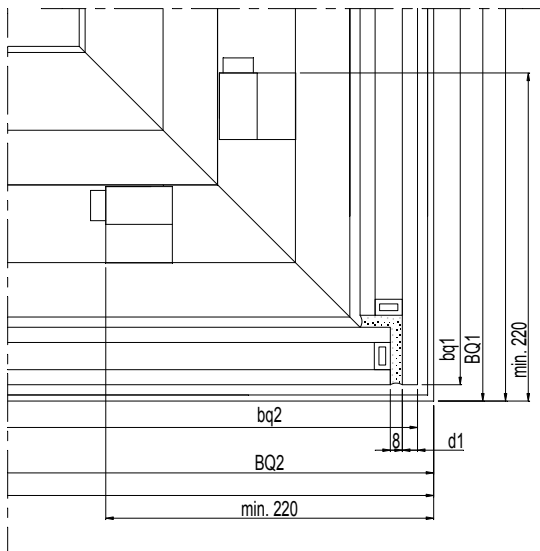
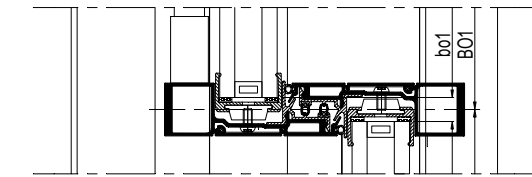
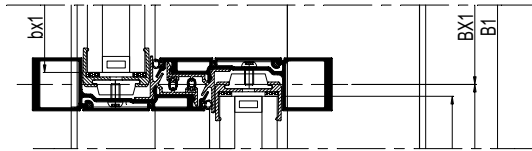





VERLIJMING TER PLAATSE DOOR GLASLEVERANCIER  
COLLÉ SUR PLACE PAR LE FOURNISSEUR DU VERRE  
GLUING DONE ON SITE BY GLASS SUPPLIER  
GLASLIEFERANT KLEBT ZUSAMMEN IN-SITU

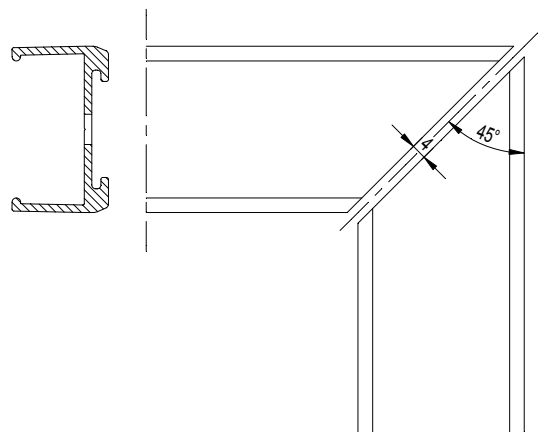
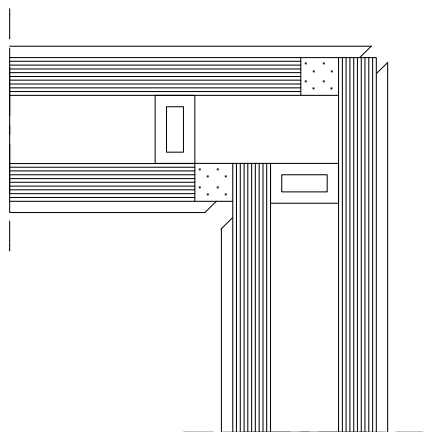
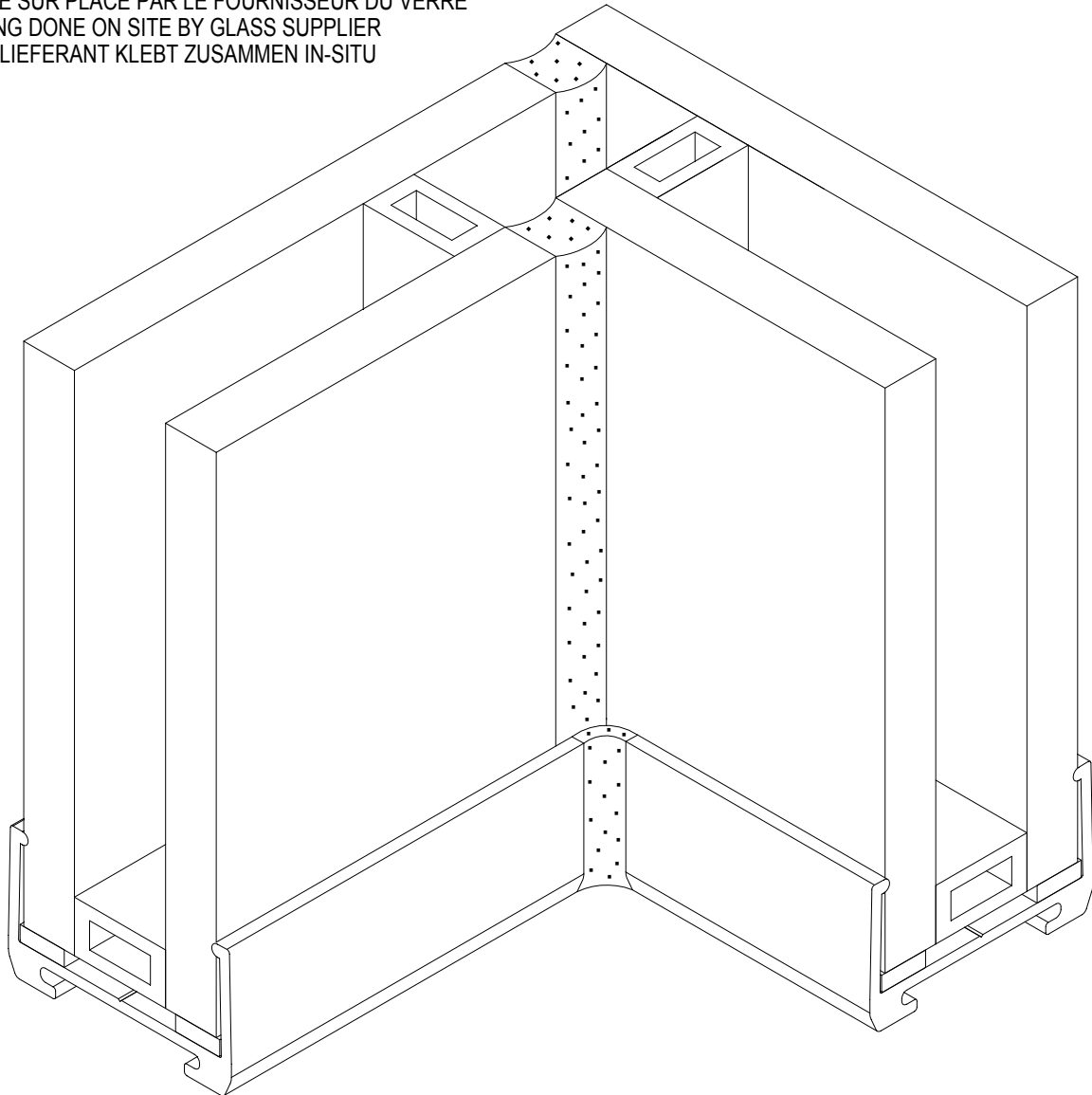

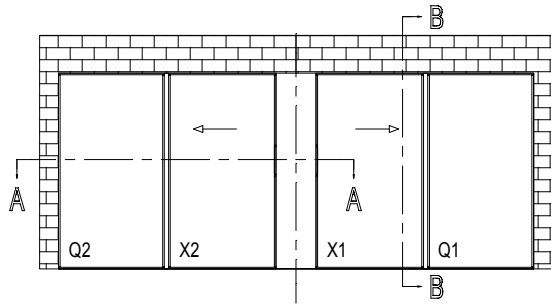

B - B

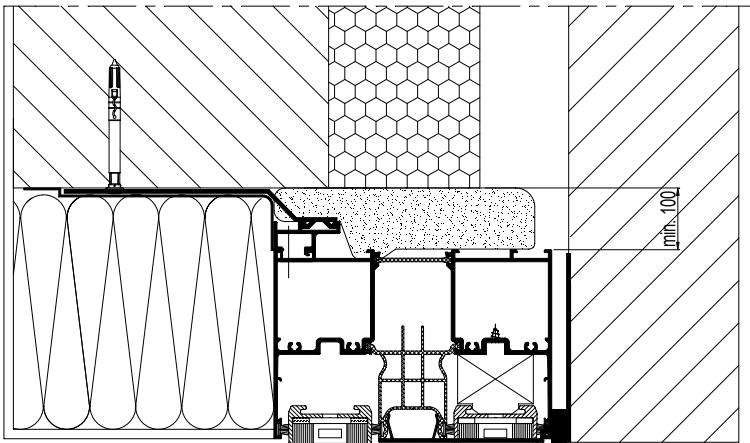

B - B

106.1383.XX

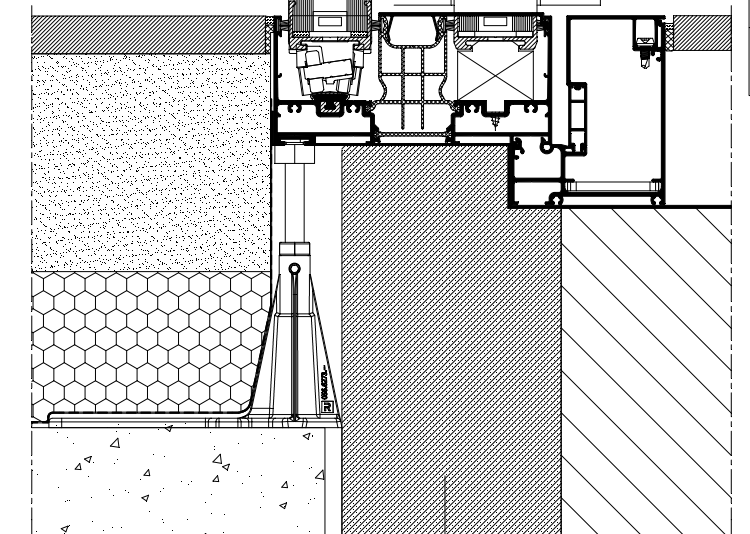

## Outside Corner

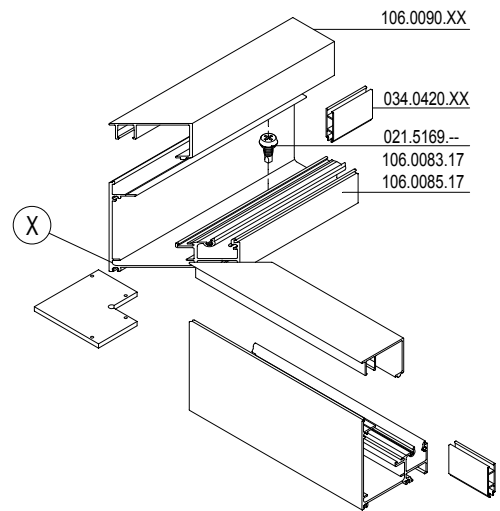
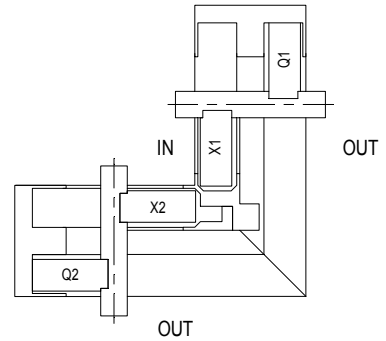

Icon	Icon	Icon	#	L <sub>m</sub>	Icon
106.0083.17	[Symbol]	[Symbol]	1	B1 - 10	25D.C. ...
		[Symbol]	1	B2 - 10	
106.0090.XX	[Symbol]	[Symbol]	1	B1 - 10	25D.C. ...
		[Symbol]	1	B2 - 10	
034.0420.XX	[Symbol]	[Symbol]	1/500mm	50	25D.C. ...

Icon	Icon	#	Icon
080.9381.04	[Symbol]	B	ACCESS CS
062.9290.17	[Symbol]	2	25D.G. ...
052.5300.--	[Symbol]	8	25D.G. ...
021.5169.--	[Symbol]	1/800mm	ACCESS CS
068.7457.00	[Symbol]	1	25D.G. ...

**!** DRUKVASTE ISOLERENDE STEENLAAG  
 ASSISE ISOLANTE ET RÉSISTANTE À LA COMPRESSION  
 COMPRESSION-RESISTANT INSULATING LAYER OF STONES  
 DRUCKFESTE ISOLIERENDE BACKSTEINSCHICHT

## A-A

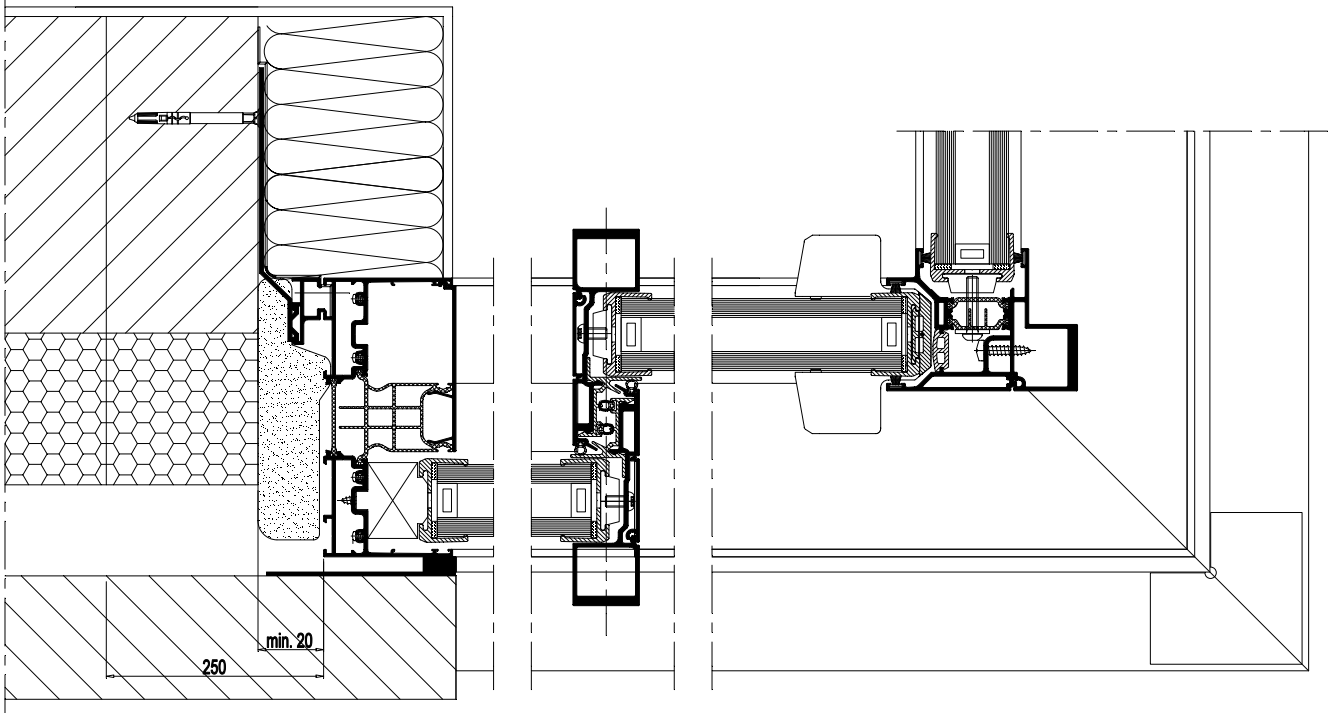

			#	$L_m$	
106.0085.17			1	B1 - 10	25D.C. ...
			1	B2 - 10	
106.0090.XX			1	B1 - 10	25D.C. ...
			1	B2 - 10	
034.0420.XX			2/500mm	50	25D.C. ...

		#	
080.9381.04		B	ACCESS CS
062.9291.17		2	25D.G. ...
052.5300.--		8	25D.G. ...
021.5169.--		1/800mm	ACCESS CS
068.7457.00		1	25D.G. ...

## B-B

106.1385.XX

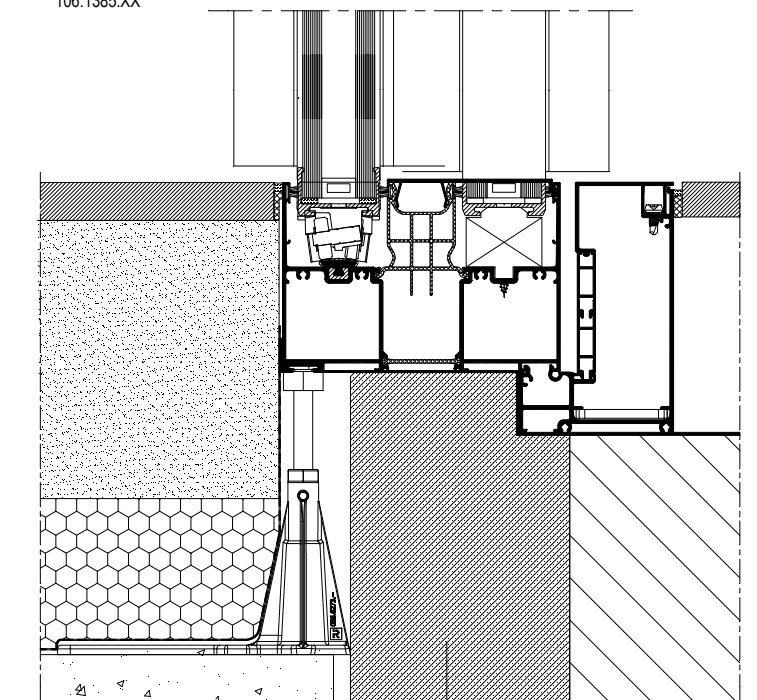

## Inside Corner

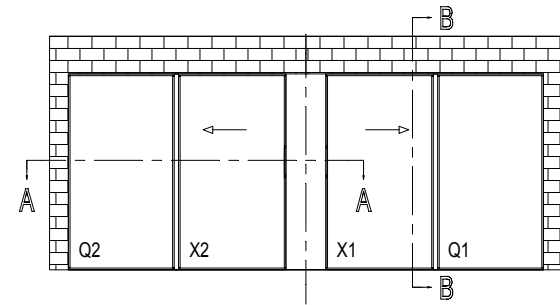
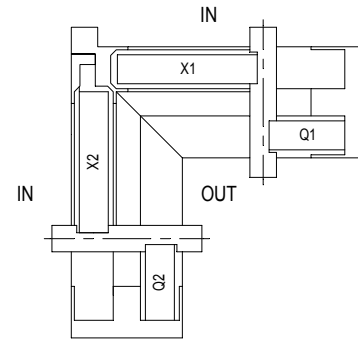

B-B

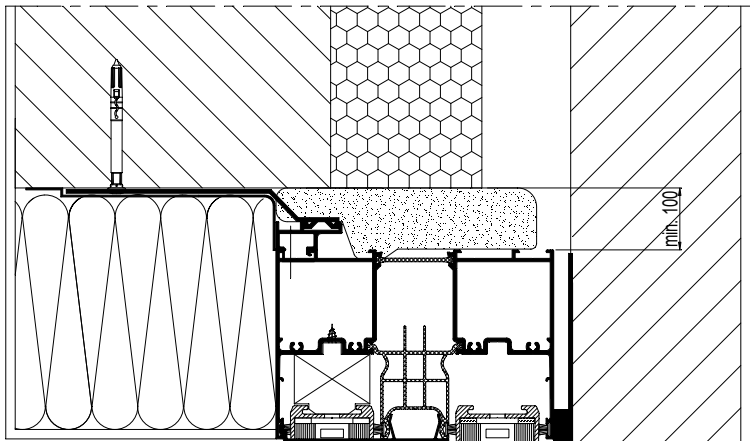

B-B

106.1383.XX

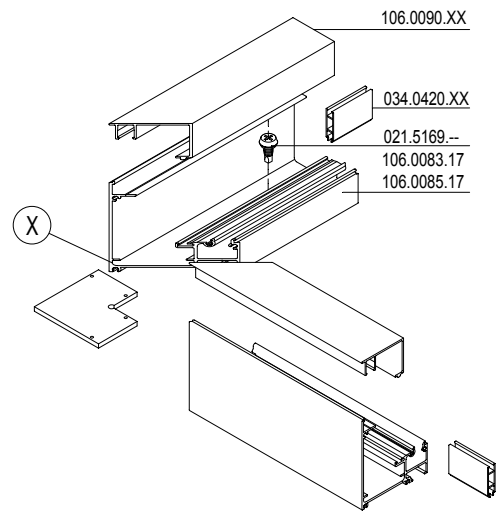
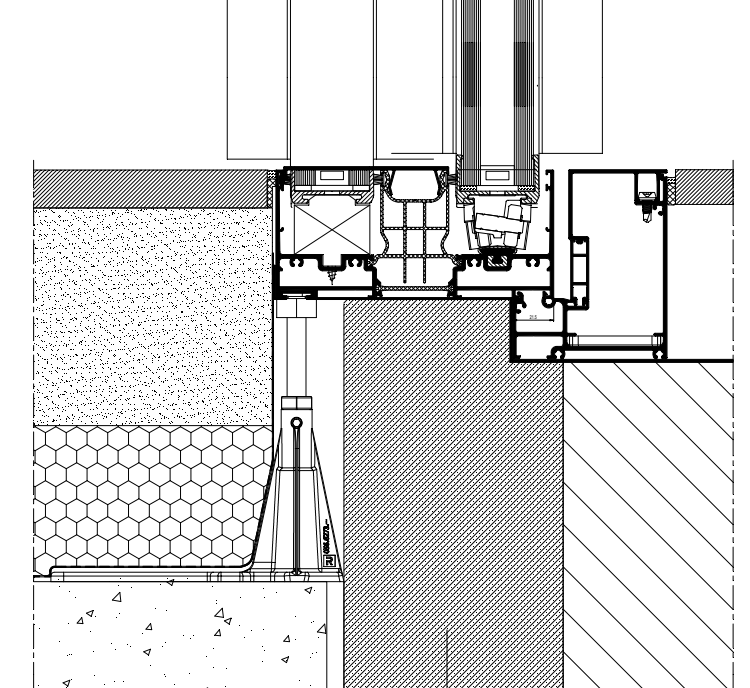

Icon	Icon	Icon	#	Ln	Icon
106.0083.17	[Icon]	[Icon]	1	B1 - 195.5	25D.C. ...
		[Icon]	1	B2 - 195.5	
106.0090.XX	[Icon]	[Icon]	1	B1 - 195.5	25D.C. ...
		[Icon]	1	B2 - 195.5	
034.0420.XX	[Icon]	[Icon]	1/500mm	50	25D.C. ...

Icon	Icon	#	Icon
080.9381.04	[Icon]	B	ACCESS CS
062.9290.17	[Icon]	2	25D.G. ...
052.5300.--	[Icon]	8	25D.G. ...
021.5169.--	[Icon]	1/800mm	ACCESS CS
068.7457.00	[Icon]	1	25D.G. ...

**!** DRUKVASTE ISOLERENDE STEENLAAG  
 ASSISE ISOLANTE ET RÉSISTANTE À LA COMPRESSION  
 COMPRESSION-RESISTANT INSULATING LAYER OF STONES  
 DRUCKFESTE ISOLIERENDE BACKSTEINSCHICHT

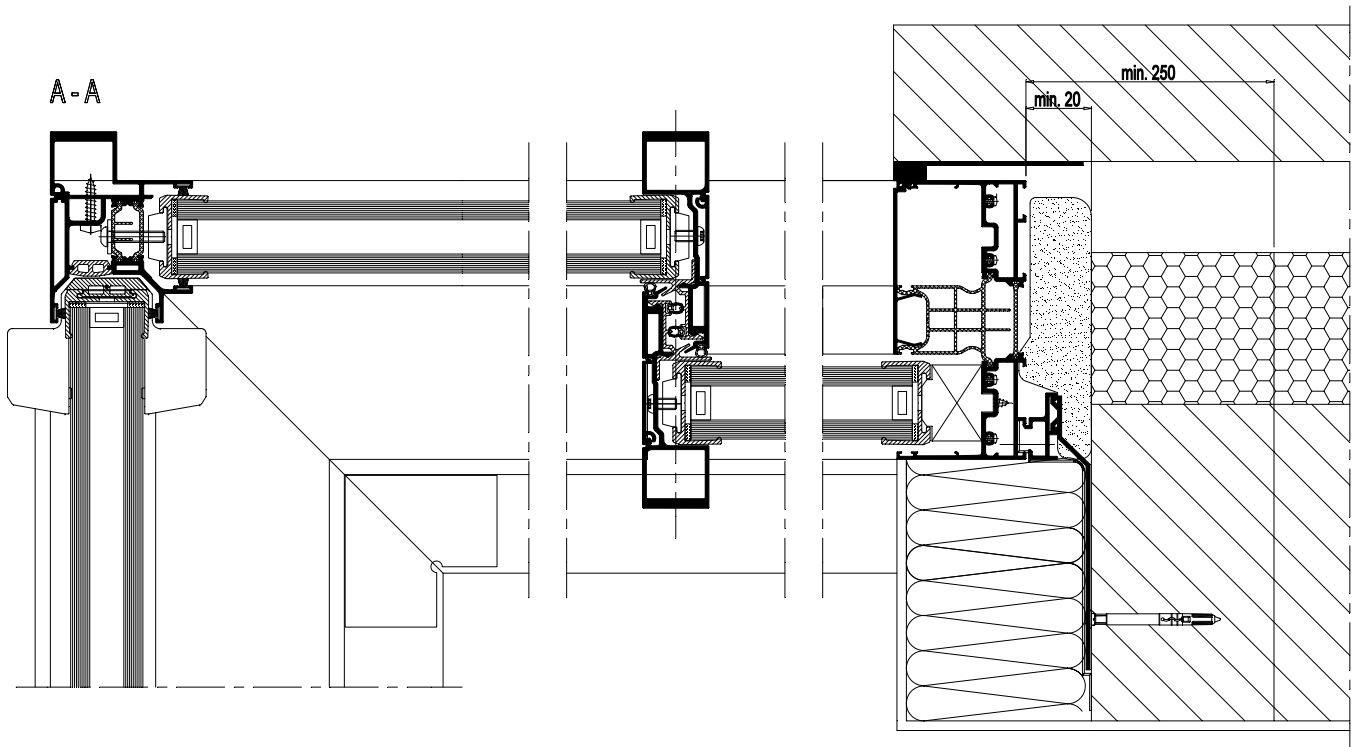

			#	$L_m$	
106.0085.17			1	B1 - 195.5	25D.C. ...
			1	B2 - 195.5	
106.0090.XX			1	B1 - 195.5	25D.C. ...
			1	B2 - 195.5	
034.0420.XX			2/500mm	50	25D.C. ...

### B - B

106.1385.XX

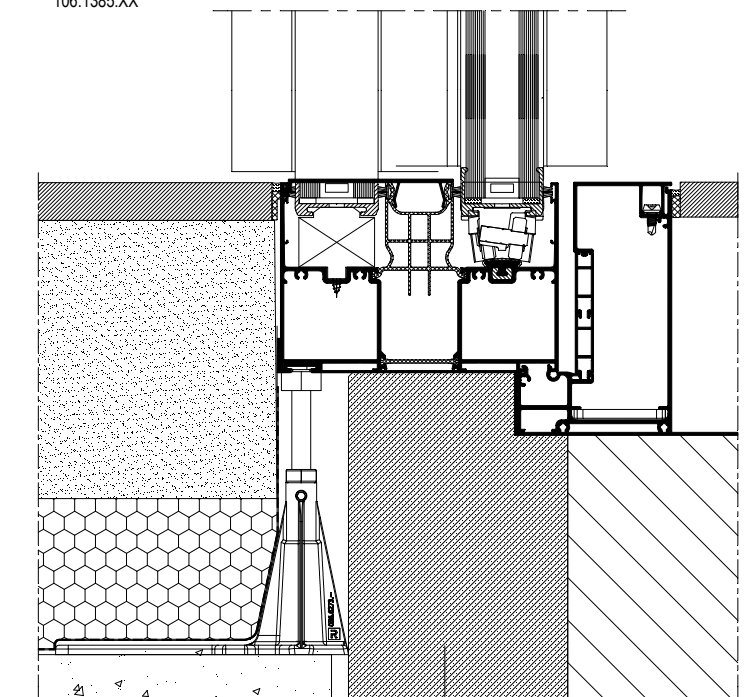

		#	
080.9381.04		B	ACCESS CS
062.9291.17		2	25D.G. ...
052.5300.--		8	25D.G. ...
021.5169.--		1/800mm	ACCESS CS
068.7457.00		1	25D.G. ...



# HFP 147

BOUWAANSLUITING - CORNER CONCAVE  
RACCORDEMENT AU BATIMENT - CORNER CONCAVES  
BUILDING CONNECTION - CORNER CONCAVE  
BAUANSCHLUSS - CORNER CONCAVE



**G**



Toebehoren





Accessoires

Accessories





Zubehör











Art. N°			Art. N°		
021.5169.--	25D.G.012	D0095256			
029.5626.04	25D.G.007	D0095252			
029.5626.04	25D.G.013	D2000465			
050.5115.--	25D.G.013	D2000465			
052.5300.--	25D.G.012	D0095256			
052.5315.--	25D.G.012	D0095256			
052.5321.--	25D.G.012	D0095256			
056.6270.--	25D.G.019	D0095260			
056.6273.--	25D.G.019	D0095260			
062.7710.04	25D.G.015	D0095257			
062.7717.04	25D.G.017	D0095259			
062.7775.XX	25D.G.003	D0095248			
062.7823.--	25D.G.020	D0096027			
062.8046.04	25D.G.007	D0095252			
062.8081.04	25D.G.007	D0095252			
062.8085.00	25D.G.018	D2000450			
062.8086.00	25D.G.018	D2000450			
062.8087.00	25D.G.018	D2000450			
062.8088.00	25D.G.018	D2000450			
062.8160.XX	25D.G.017	D0095259			
062.8161.XX	25D.G.017	D0095259			
062.8176.04	25D.G.015	D0095257			
062.8180.00	25D.G.015	D0095257			
062.8182.00	25D.G.016	D0095371			
062.8190.--	25D.G.016	D0095371			
062.8195.07	25D.G.005	D0095250			
062.8200.--	25D.G.005	D0095250			
062.8201.--	25D.G.005	D0095250			
062.8205.XX	25D.G.006	D0095251			
062.8210.--	25D.G.004	D0095249			
062.8220.--	25D.G.006	D0095251			
062.8226.--	25D.G.004	D0095249			
062.9290.17	25D.G.017	D0095259			
062.9291.17	25D.G.017	D0095259			
062.9309.04	25D.G.008	D0095253			
062.9310.04	25D.G.008	D0095253			
062.9319.04	25D.G.008	D0095253			
062.9320.04	25D.G.008	D0095253			
062.9425.04	25D.G.011	D2000449			
062.9426.04	25D.G.011	D2000449			
062.9427.04	25D.G.011	D2000449			
062.9428.04	25D.G.011	D2000449			
062.9429.04	25D.G.011	D2000449			
067.5216.--	25D.G.013	D2000465			
068.7457.00	25D.G.018	D2000450			
069.6830.04	25D.G.014	D0095258			
069.6831.XX	25D.G.014	D0095258			
071.6904.07	25D.G.016	D0095371			
080.8442.04	25D.G.009	D0095254			
080.9150.04	25D.G.007	D0095252			
080.9151.04	25D.G.007	D0095252			
080.9381.04	25D.G.010	D0095255			
080.9454.04	25D.G.009	D0095254			
081.9135.SY	25D.G.008	D0095253			
084.9114.04	25D.G.016	D0095371			

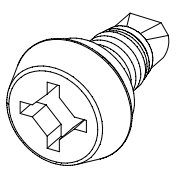
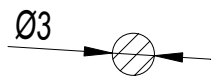
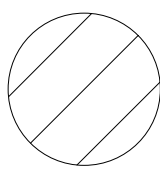
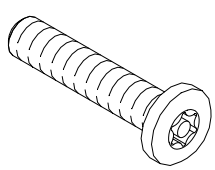
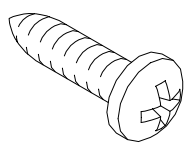
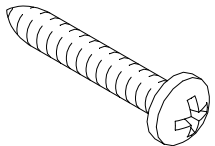
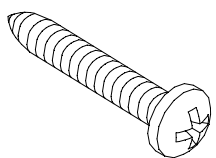
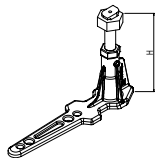
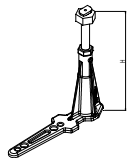
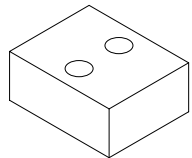
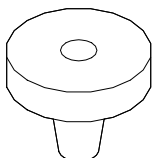
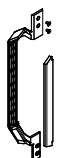
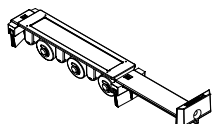
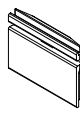
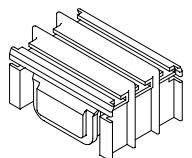
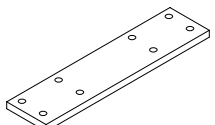
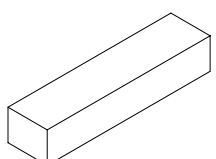
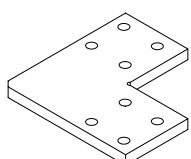
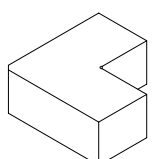
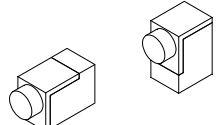
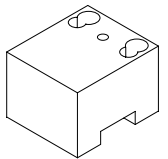
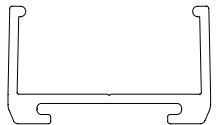
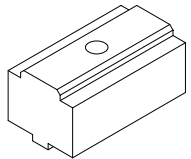
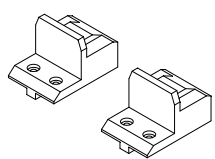
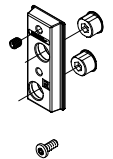
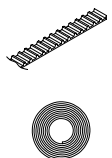
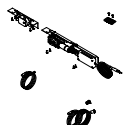

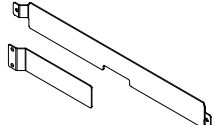
Art. N°			Art. N°		
095.C321.00 097.0102.00 097.0103.00 097.0107.00 097.0133.00	25D.G.021 25D.G.021 25D.G.021 25D.G.021 25D.G.021	D0095261 D0095261 D0095261 D0095261 D0095261			

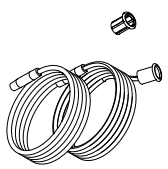
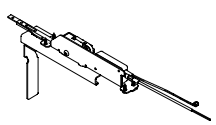
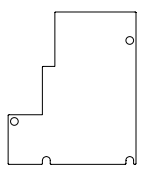
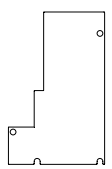
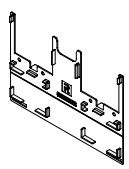

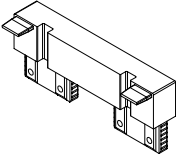
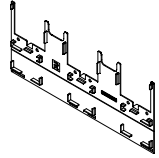
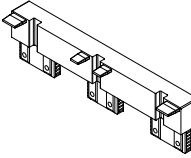
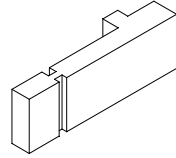
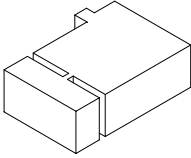
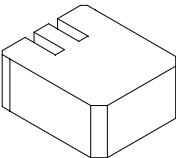
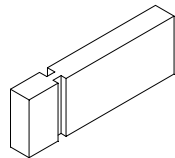
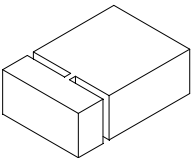
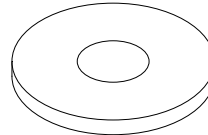
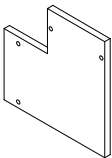
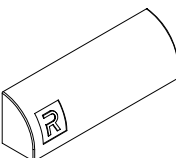
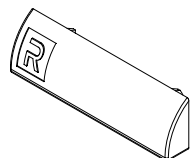
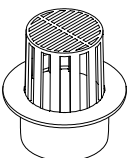
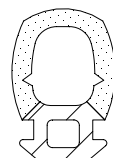
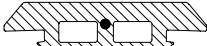
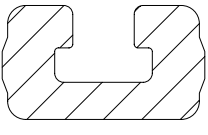
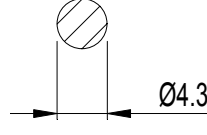
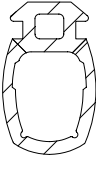
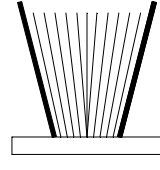
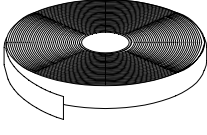
021.5169.-- (25D.G.012) 	029.5626.04 (25D.G.007) 	029.5626.04 (25D.G.013) 	050.5115.-- (25D.G.013) 	052.5300.-- (25D.G.012) 
052.5315.-- (25D.G.012) 	052.5321.-- (25D.G.012) 	056.6270.-- (25D.G.019) 	056.6273.-- (25D.G.019) 	062.7710.04 (25D.G.015) 
062.7717.04 (25D.G.017) 	062.7775.XX (25D.G.003) 	062.7823.-- (25D.G.020) 	062.8046.04 (25D.G.007) 	062.8081.04 (25D.G.007) 
062.8085.00 (25D.G.018) 	062.8086.00 (25D.G.018) 	062.8087.00 (25D.G.018) 	062.8088.00 (25D.G.018) 	062.8160.XX (25D.G.017) 
062.8161.XX (25D.G.017) 	062.8176.04 (25D.G.015) 	062.8180.00 (25D.G.015) 	062.8182.00 (25D.G.016) 	062.8190.-- (25D.G.016) 
062.8195.07 (25D.G.005) 	062.8200.-- (25D.G.005) 	062.8201.-- (25D.G.005) 	062.8205.XX (25D.G.006) 	062.8210.-- (25D.G.004) 
062.8220.-- (25D.G.006) 	062.8226.-- (25D.G.004) 	062.9290.17 (25D.G.017) 	062.9291.17 (25D.G.017) 	062.9309.04 (25D.G.008) 

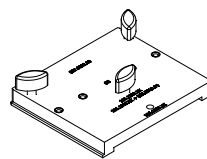
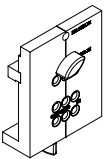
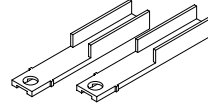
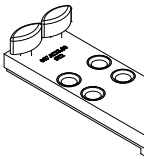
062.9310.04 (25D.G.008)	062.9319.04 (25D.G.008)	062.9320.04 (25D.G.008)	062.9425.04 (25D.G.011)	062.9426.04 (25D.G.011)
				
062.9427.04 (25D.G.011)	062.9428.04 (25D.G.011)	062.9429.04 (25D.G.011)	067.5216.-- (25D.G.013)	068.7457.00 (25D.G.018)
				
069.6830.04 (25D.G.014)	069.6831.XX (25D.G.014)	071.6904.07 (25D.G.016)	080.8442.04 (25D.G.009)	080.9150.04 (25D.G.007)
				
080.9151.04 (25D.G.007)	080.9381.04 (25D.G.010)	080.9454.04 (25D.G.009)	081.9135.SY (25D.G.008)	084.9114.04 (25D.G.016)
				
095.C321.00 (25D.G.021)	097.0102.00 (25D.G.021)	097.0103.00 (25D.G.021)	097.0107.00 (25D.G.021)	097.0133.00 (25D.G.021)
				

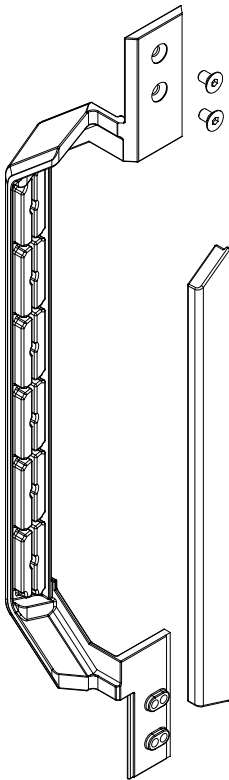

## 062.7775.XX

HANDGREEP HFP147  
MAIN COURANTE HFP147  
HANDRAIL HFP147  
HANDLAUF HFP147

HFP 147



## 062.8210.--

BEVESTIGINGSSET EN MOTORSLOT  
 SET DE FIXATION ET SERRURE MOTEUR  
 FIXATION SET AND LOCKS MOTOR  
 BEFESTIGUNGSSATZ UND SCHLOESSER ANTRIEB

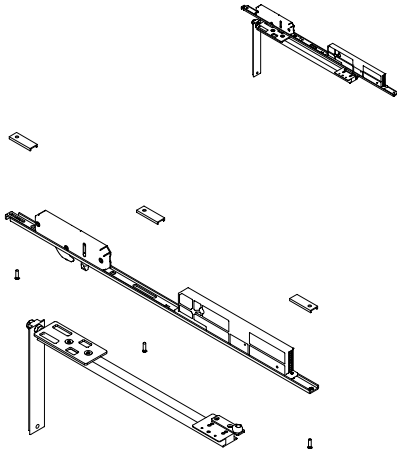

HFP 147  
 HFP 179

## 062.8226.--

BEVESTIGINGSSET  
 SET DE FIXATION  
 FIXATION SET  
 BEFESTIGUNGSSATZ

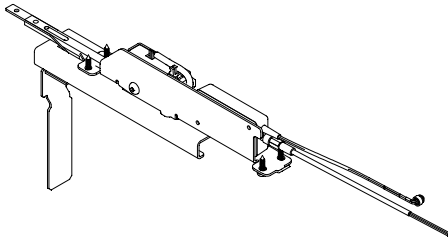



HFP 147  
 HFP 179



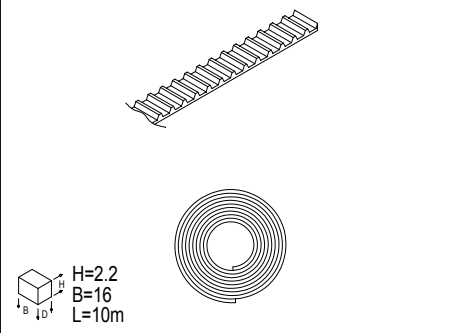
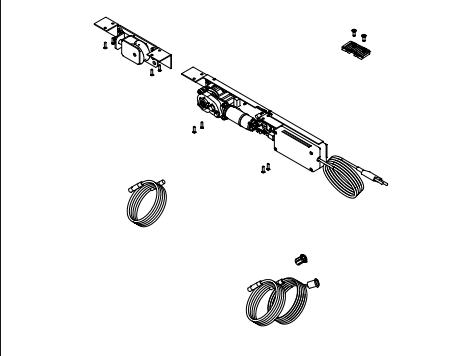
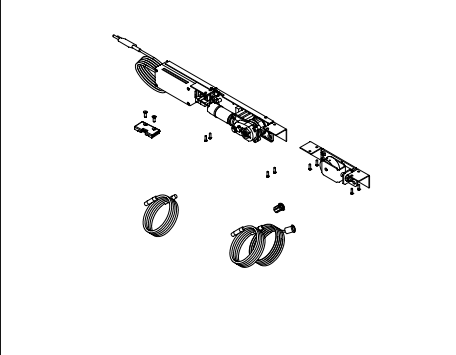



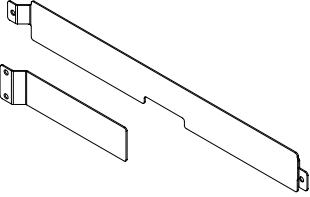







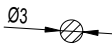
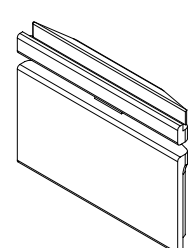
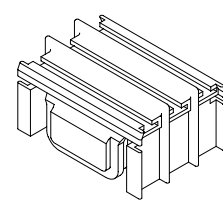
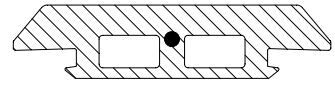

	<p><b>062.8195.07</b> TANDRIEM COURROIE DENTEE GEARED BELT ZAHNRIEMEN</p>	<p>HFP 147 HFP 179</p>		
	<p><b>062.8200.--</b> MOTOR DIN R MOTEUR DIN R MOTOR DIN R ANTRIEB DIN R</p>	<p>HFP 147 HFP 179</p>		
	<p><b>062.8201.--</b> MOTOR DIN L MOTEUR DIN L MOTOR DIN L ANTRIEB DIN L</p>	<p>HFP 147 HFP 179</p>		

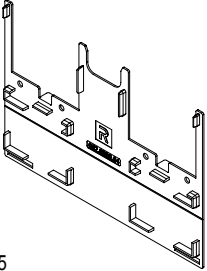
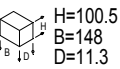
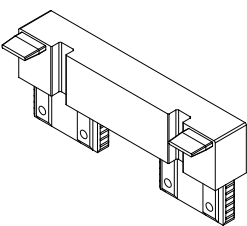
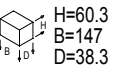
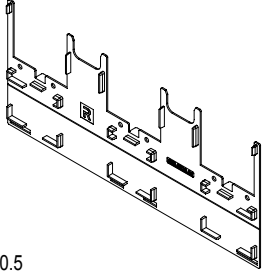
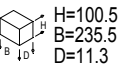
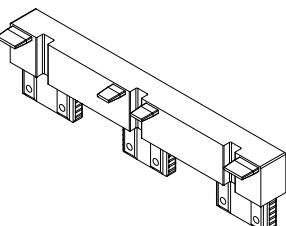
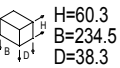

	<p><b>062.8205.XX</b>          AFDEKPLAAT          TOLE DE RECOUVREMENT          COVER PLATE          ABDECKPLATTE</p>	<p>HFP 147          HFP 179</p>		
	<p><b>062.8220.--</b>          DRUKKNOPSCHAKELAAR          INTERRUPTEUR A POUSSOIR          PUSH BUTTON SWITCH          DRUCKKNOPFSCHALTER</p>	<p>HFP 147          HFP 179</p>		
Empty space for additional accessories				

				
	<p><b>029.5626.04</b> DICHTING Ø3MM JOINT Ø3MM GASKET Ø3MM DICHTUNG Ø3MM</p>	<p>HFP 147 HFP 179 CS 77 CP 45Pa ES 45Pa CSW 86-HI</p>		
 <p>H=22 B=30 D=5.6</p>	<p><b>062.8046.04</b> AFSTANDSSTUK PIECE D'ECARTEMENT DISTANCE PIECE Distanzstueck</p>	<p>HFP 147 HFP 179</p>		
	<p><b>062.8081.04</b> AFDICHTING FERMETURE CLOSER ABDICHTUNG</p>	<p>HFP 147 HFP 179</p>		
	<p><b>080.9150.04</b> DICHTING JOINT GASKET DICHTUNG</p>	<p>HFP 147</p>		
	<p><b>080.9151.04</b> DICHTING JOINT GASKET DICHTUNG</p>	<p>HFP 147 HFP 179</p>		

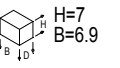
				
 	<p><b>062.9309.04</b>            AFDICHTING VAST KADER            FERMETURE DORMANT            END PIECE FIXED FRAME            ABDICHTUNG BLENDRAHMEN</p>	HFP 147		
 	<p><b>062.9310.04</b>            HOEKSTUK            PIECE D'ANGLE            CORNER PIECE            ECKSTUECK</p>	HFP 147		
 	<p><b>062.9319.04</b>            AFDICHTING VAST KADER            FERMETURE DORMANT            END PIECE FIXED FRAME            ABDICHTUNG BLENDRAHMEN</p>	HFP 147		
 	<p><b>062.9320.04</b>            HOEKSTUK            PIECE D'ANGLE            CORNER PIECE            ECKSTUECK</p>	HFP 147		
 	<p><b>081.9135.SY</b>            BORSTELDICHTING            JOINT-BROSSE            WOOLPILE            BUERSTENDICHTUNG</p>	HFP 147 HFP 179		



## 080.8442.04

AKOESTISCHE DICHTING  
JOINT ACOUSTIQUE  
ACOUSTIC GASKET  
SCHALLDICHTUNG



CP 130  
CP 130-LS

HFP 147  
HFP 179  
ES 50  
CS 38-SL  
CS 86-HI  
ES 50-AP  
CS 38-SL/AP  
CF 77  
CS 104  
CF 77-AP  
ES 45Pa  
CF 68

H=8.5  
B=5.76

## 080.9454.04

AKOESTISCHE DICHTING  
JOINT ACOUSTIQUE  
ACOUSTIC GASKET  
SCHALLDICHTUNG



CS 59Pa	CS 59Pa-AES	ES 50 Optima-AP
CS 59Pa-AD	CS 59-AP	CS 104
CS 59Pa-CD	CS 68-APCS	CS 38-SL Optima
CS 59Pa-SD	CS 77-AP	CS 77 Optima
CS 59	CS 77-BP	
CS 59-HV	CS 77-FP	
CS 59-Re	CS 68 Optima	
CS 59-So	CS 59-PD	
CS 59-AD	CS 68-PD	
CS 59-CD	CS 77-PD	
CS 59-SD	CS 38-SL	
CS 68	CS 86-HI	
CS 68-HV	CS 38-SL/AP	
CS 68-Re	CS 24-SL	
CS 68-So	CS 24-SL/AP	
HFP 147	CS 38-SL/FP	
HFP 179	CS 77-Re	
CS 68-FP	ES 50 Optima	
CS 77	CS 86-HI/AP	
CS 77-HVCS	CS 68 Optima-AP	



## 080.9381.04

DICHTING Ø4.3MM  
JOINT Ø4.3MM  
GASKET Ø4.3MM  
DICHTUNG Ø4.3MM

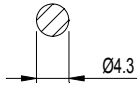



- |              |             |
|--------------|-------------|
| CS 59        | CS 86-HI    |
| CP 155       | CS 38-SL/AP |
| CP 155-LS    | PR 100      |
| CW 50        | ES 75       |
| CW 50-HI     | CD 45Pa     |
| CW 50-HL     | CS 104      |
| CW 50-RA     | XS 68       |
| CW 60        | CS 77-SP    |
| CW 50-SC     | CI 45       |
| CW 50-SG     | CSW 86-HI   |
| CW 60-SG     |             |
| CW 50-SL     |             |
| CP 155-AP    |             |
| CP 155-LS/AP |             |
| ES 50        |             |
| ES 50-AP     |             |
| CS 24-SL     |             |
| CW 60-SC     |             |
| CW 60-HI     |             |
| CW 60-HL     |             |
| CS 24-SL/AP  |             |
| CW 65-EF     |             |
| CW 65-EF/SG  |             |
| CW 65-EF/HI  |             |
| CW 50-VL     |             |
| CS 59Pa      |             |
| CS 59-HV     |             |
| CS 59-Re     |             |
| CS 59-So     |             |
| CS 68        |             |
| CS 68-HV     |             |
| CS 68-Re     |             |
| CS 68-So     |             |
| VISION 50    |             |
| TP 110       |             |
| TLS 110      |             |
| CP 130       |             |
| CP 130-LS    |             |
| HFP 147      |             |
| HFP 179      |             |
| TR 200       |             |
| BOREALE      |             |
| CR 120       |             |
| CS 77        |             |
| CW 86        |             |
| CS 77-HV     |             |
| REYNASCREEN  |             |
| CS 77-FP     |             |
| CP 96        |             |
| CP 45Pa      |             |
| CW 86-EF     |             |
| CP 96-LS     |             |
| TP 110-Re    |             |
| CS 38-SL     |             |

 Ø4.3  
EPDM DENSITY 0.5



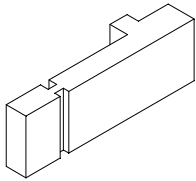
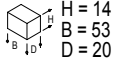
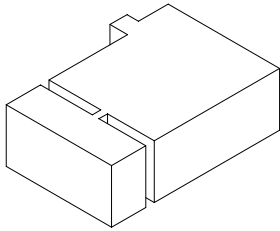
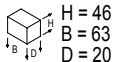
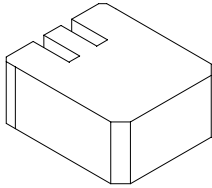
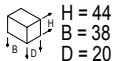
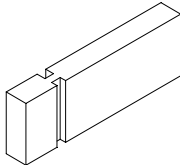
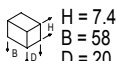
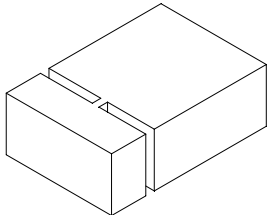
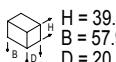

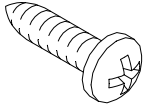
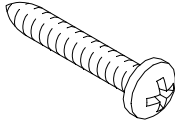
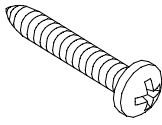

D00095255



 	<p><b>062.9425.04</b>                  AFDICHTINGSSCHUIM                  MOUSSE D'ETANCHEITE                  SEALING FOAM                  SCHAUMSCHOTT</p>	<p>HFP 147                  HFP 179</p>		
 	<p><b>062.9426.04</b>                  AFDICHTINGSSCHUIM                  MOUSSE D'ETANCHEITE                  SEALING FOAM                  SCHAUMSCHOTT</p>	<p>HFP 147                  HFP 179</p>		
 	<p><b>062.9427.04</b>                  AFDICHTINGSSCHUIM                  MOUSSE D'ETANCHEITE                  SEALING FOAM                  SCHAUMSCHOTT</p>	<p>HFP 147                  HFP 179</p>		
 	<p><b>062.9428.04</b>                  AFDICHTINGSSCHUIM                  MOUSSE D'ETANCHEITE                  SEALING FOAM                  SCHAUMSCHOTT</p>	<p>HFP 147                  HFP 179</p>		
 	<p><b>062.9429.04</b>                  AFDICHTINGSSCHUIM                  MOUSSE D'ETANCHEITE                  SEALING FOAM                  SCHAUMSCHOTT</p>	<p>HFP 147                  HFP 179</p>		

	<p><b>021.5169.--</b>          100 SCHROEF ZELFBOREND M5x11          100 VIS AUTOPERCEUSE M5x11          100 SCREW SELF-DRILLING M5x11          100 BLECHSCHRAUBE M5x11</p>	<p>CS 59          CS 68          CS 77          CS 68 Optima          ES 50          CS 38-SL          CS 86-HI          CD 50          CS 38-SL/AP          ES 50 Optima          CS 104          CS 77 Optima</p>	<p>CS 59Pa          VISION 50          HIFI          HFP 147          HFP 179          CP 45Pa          ES 50-AP          VENTALIS          CS 45Pa          CD 45Pa</p>	
	<p><b>052.5300.--</b>          ZT SCHROEF DIN 7981 INOX 4.8x19          VIS PARKER DIN 7981 INOX 4.8x19          ST-SCREW DIN 7981 INOX 4.8x19          BLECHSCHRAUBE DIN 7981 INOX 4.8x19</p>	<p>HFP 147          HFP 179          MEDAS          CW 86</p>		
	<p><b>052.5315.--</b>          ZT SCHROEF DIN 7981 INOX 4.2x25          VIS PARKER DIN 7981 INOX 4.2x25          ST-SCREW DIN 7981 INOX 4.2x25          BLECHSCHRAUBE DIN 7981 INOX 4.2x25</p>	<p>CS 59Pa          CS 59Pa-AD          CS 59          CS 59-AD          CS 68          TP 110          TLS 110          CP 130          CP 130-LS          CP 155          CP 155-LS          MOSQUITO          CS 68-FP          CS 77          ES 50          CS 86-HI          ES 50-AP          CS 24-SL          CS 24-SL/AP          BS 40          VENTALIS          ES 75          CF 77          CF 77-AP          VISION 50          HFP 147</p>	<p>HFP 179          TR 200          CW 86          CP 96-LS          CP 96-LS/AP          CS 38-SL          CD 45Pa</p>	
	<p><b>052.5321.--</b>          SCHROEF DIN 7981 INOX 4.2x32          VIS DIN 7981 INOX 4.2x32          SCREW DIN 7981 INOX 4.2x32          SCHRAUBE DIN 7981 INOX 4.2x32</p>	<p>VISION 50          CF 77          CP 45Pa (GR)          CF 77-AP          CF 68          HFP 147          HFP 179          CW 86          ES 50          ES 50-AP          ES 75</p>		

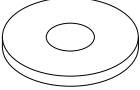
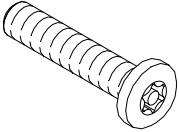

 	 	
	<p><b>029.5626.04</b> DICHTING Ø3MM JOINT Ø3MM GASKET Ø3MM DICHTUNG Ø3MM</p>	<p>HFP 147 HFP 179 CS 77 CP 45Pa ES 45Pa CSW 86-HI</p>
	<p><b>067.5216.--</b> RONDEL M6 1.6 RONDELLE M6 1.6 WASHER M6 1.6 SCHEIBE M6 1.6</p>	<p>HFP 147 HFP 179</p>
	<p><b>050.5115.--</b> VEILIGHEIDSSCHROEF TORX + PIN ISO7380 M6x30 VIS DE SECURITE TORX + TETON ISO7380 M6x30 SAFETY SCREW WITH TORX + PIN ISO7380 M6x30 SICHERHEITZSCHRAUBE TORX + PIN ISO7380 M6x30</p>	<p>HFP 147 HFP 179</p>
Empty row for additional accessories		



## 069.6830.04

AFDEKKAP WATERAFVOERSLEUVEN  
CAPUCHON DRAINAGE D'EAU  
WEEP HOLE COVER  
ABDECKKAPPE ENTWAESSERUNG

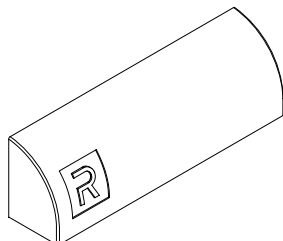

CP 130  
CP 45Pa  
CP 45Pa (GR)

CP 155  
CP 155-LS  
HFP 147  
HFP 179  
CP 96  
CF 68

H=14  
B=10  
D=46

## 069.6831.XX



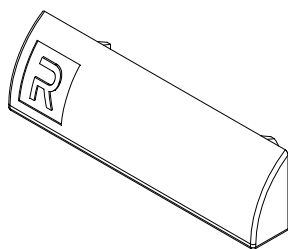

AFDEKKAP WATERAFVOERSLEUVEN  
CAPUCHON DRAINAGE D'EAU  
WEEP HOLE COVER  
ABDECKKAPPE ENTWAESSERUNG





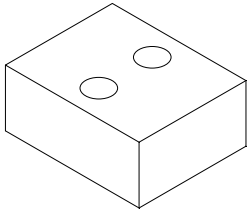

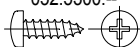
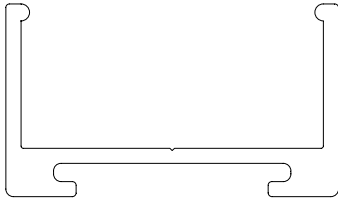
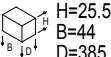
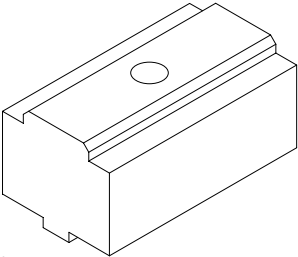

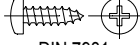





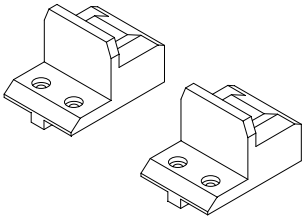

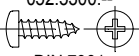
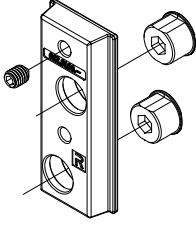
CS 59Pa	CP 155-LS	CS 68 Optima	CF 68
CS 59Pa-AD	HFP 147	CS 59-PD	
CS 59Pa-CD	HFP 179	CS 68-PD	
CS 59Pa-SD	CS 68-FP	CS 77-PD	
CS 59	CS 77	ES 50	
CS 59-HV	CS 77-HV	CS 86-HI	
CS 59-Re	CS 59Pa-AP	CD 50	
CS 59-So	CS 59-AP	ES 50-AP	
CS 59-AD	CS 68-AP	CS 77-Re	
CS 59-CD	CS 77-AP	ES 50 Optima	
CS 59-SD	CS 77-BP	ES 75	
CS 68	CS 77-FP	CS 86-HI/AP	
CS 68-HV	TP 110-AFCS	CS 68 Optima-AP	
CS 68-Re	CP 155-AFES	ES 50 Optima-AP	
CS 68-So	CP 155-LS/AP	CF 77	
TP 110	CP 96	CS 104	
TLS 110	CP 96-LS	CS 77-SP	
CP 130	CP 96-AP	ES 50-PL	
CP 130-LS	CP 96-LS/AP	CF 77-AP	
CP 155	TP 110-Re	ES 45Pa	

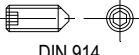
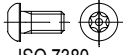
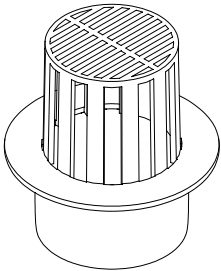
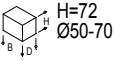
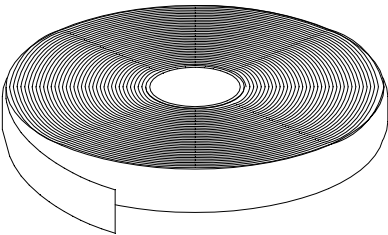
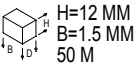
H=13  
B=44  
D=11.3

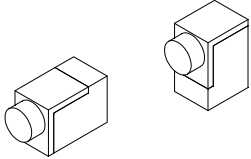

 	<p><b>062.7710.04</b></p> <p>BUFFER BUTEE BUFFER STOPPER</p>	<p>HFP 147 HFP 179</p>	 <p>2 st./pc 052.5300.--</p>  <p>DIN 7981 4.8 x 19</p>
 	<p><b>062.8176.04</b></p> <p>U-PROFIEL PROFILE-U U-PROFILE U-PROFIL</p>	<p>HFP 147</p>	
 	<p><b>062.8180.00</b></p> <p>STEUNSTUK VASTE VLEUGEL PIECE DE SUPPORT OUVRANT FIXE SUPPORTING PIECE FIXED FRAME STUETZKLOTZ FESTEN FLUEGEL</p>	<p>HFP 147 HFP 179</p>	 <p>1 st./pc 052.5300.--</p>  <p>DIN 7981 4.8 x 19</p>

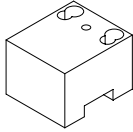
				
 	<p><b>062.8182.00</b>                      STEUNSTUK                      PIECE DE SUPPORT                      SUPPORTING PIECE                      STUETZKLOTZ</p>	<p>HFP 147 HFP 179</p>		<p>4 st./pc 052.5300.--                        DIN 7981 4.8 x 19</p>
 	<p><b>062.8190.--</b>                      STELBLOKJE                      CALE D'AJUSTEMENT                      ADJUSTING BLOCK                      DISTANZKLOTZ</p>	<p>HFP 147 HFP 179</p>		<p>st./pc 051.5262.--                        DIN 914 M6 x 8                      st./pc 050.5114.--                        ISO 7380 M6 x 12</p>
 	<p><b>071.6904.07</b>                      UITLOOP DAKGOOT                      CREPINE GOUTTIERE                      CONNECTION PIECE GUTTER DRAINPIPE                      REGENABFUEHRABSCHLUSS DACHRINNE</p>	<p>CW 50 CW 60 TR 200 BOREALE CR 120</p>		<p>HFP 147 HFP 179 PR 100</p>
 	<p><b>084.9114.04</b>                      KLEEFBAND PVC                      BANDE AUTOCOLLANTE PVC                      TAPE SELF-ADHESIVE PVC                      KLEBENDES BAND PVC</p>	<p>HFP 147 HFP 179 GP 51</p>		

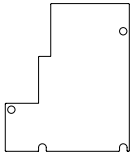
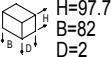
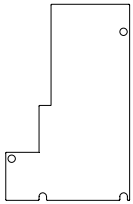
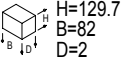
  	<p><b>062.8160.XX</b></p> <p>BUFFER BUTEE BUFFER STOPPER</p>	<p>HFP 147 HFP 179</p>		
  	<p><b>062.8161.XX</b></p> <p>AFSTANDSHOUDER REDUCTEUR DE FEUILLURE FILLISTER REDUCER FALZVERKLEINERUNGSPROFIL</p>	<p>HFP 147 HFP 179</p>		
  	<p><b>062.7717.04</b></p> <p>BUFFER BUTEE BUFFER STOPPER</p>	<p>VISION 50 TP 110 CP 130 CP 130-LS CP 155-LS HFP 147 HFP 179 TP 110-Re</p>		
  	<p><b>062.9290.17</b></p> <p>EINDSTUK PIECE FINALE END PIECE ENDSTUECK</p>	<p>HFP 147 HFP 179</p>		
  	<p><b>062.9291.17</b></p> <p>EINDSTUK ZIJKANT PIECE FINALE COTE LATERAL END PIECE SIDE ENDSTUECK SEITE</p>	<p>HFP 147 HFP 179</p>		



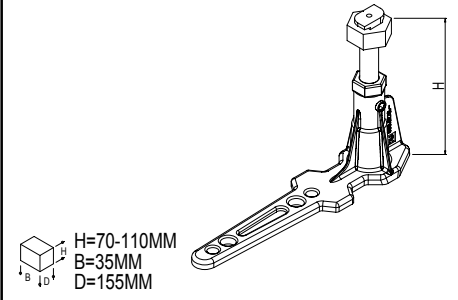
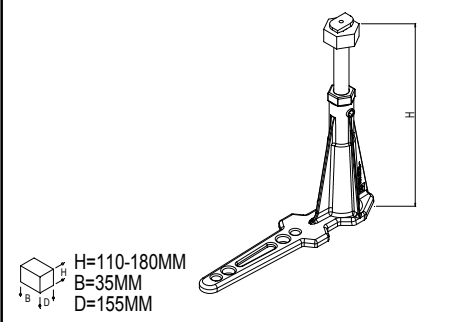

 <p>H=70-110MM B=35MM D=155MM</p>	<p><b>056.6270.--</b></p> <p>ANKER ANCRAGE ANCHOR ANKER</p>	<p>CP 130 CP 130-LS CP 155 CP 155-LS HFP 147 HFP 179 CP 155-AP CP 155-LS/AP CP 50 CP 96 CP 45Pa CP 96-LS CP 96-AP</p>	<p>CP 96-LS/AP CP 50-HI</p>
 <p>H=110-180MM B=35MM D=155MM</p>	<p><b>056.6273.--</b></p> <p>ANKER ANCRAGE ANCHOR ANKER</p>	<p>CP 130 CP 130-LS CP 155 CP 155-LS HFP 147 HFP 179 CP 155-AP CP 155-LS/AP CP 50 CP 96 CP 45Pa CP 96-LS CP 96-AP</p>	<p>CP 96-LS/AP CP 50-HI</p>



062.7823.--

LOOPWAGEN  
ROULETTES  
ROLLERS  
LAUFWAGEN

HFP 147

6 st./pc  
054.5447.--

  
DIN 6799  
12.3 x 0.7

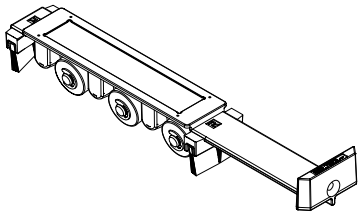

B=230  
D=44



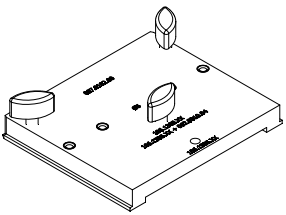
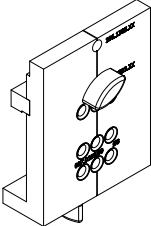
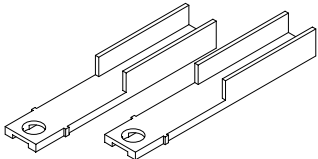
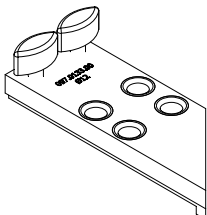

	<p><b>095.C321.00</b>                  FREES Ø12X15X95X125                  FRAISE Ø12X15X95X125                  MILLING HEAD Ø12X15X95X125                  FRAESE Ø12X15X95X125                  FREZ Ø12X15X95X125</p>	<p>HFP 147 HFP 179</p>	
	<p><b>097.0102.00</b>                  BOORMAL SCHROEFVERBINDING                  CALIBRE DE PERCAGE JONCTION A VISSER                  BORING JIG SCREW CONNECTION                  BOHRLEHRE VERSCHRAUBUNG                  SZABLON DO POLACZEN SKRECANYCH</p>	<p>HFP 147</p>	
	<p><b>097.0103.00</b>                  BOORMAL ONTWATERING                  CALIBRE DE PERCAGE DRAINAGE                  BORING JIG DRAINAGE                  BOHRLEHRE ENTWASSERUNG                  SZABLON DO DRENAZY</p>	<p>HFP 147 HFP 179</p>	
	<p><b>097.0107.00</b>                  STEUNSTUK                  PIECE DE SUPPORT                  SUPPORTING PIECE                  STUETZKLOTZ                  ELEMENT WSPORCZY</p>	<p>HFP 147 HFP 179</p>	
	<p><b>097.0133.00</b>                  BOORMAL SCHROEFVERBINDING                  CALIBRE DE PERCAGE JONCTION A VISSER                  BORING JIG SCREW CONNECTION                  BOHRLEHRE VERSCHRAUBUNG                  SZABLON DO POLACZEN SKRECANYCH</p>	<p>HFP 147 HFP 179</p>	

# HFP 147

GEREEDSCHAP  
OUTIL  
TOOL  
WERKZEUG







[www.reynaers.com](http://www.reynaers.com)